



SiciStone Collection

SICIS

www.sicis.com

SiciStone Collection

SICIS

The image shows a modern interior space with a highly reflective floor. The walls are covered in a light-colored material with a complex, geometric, maze-like pattern. In the foreground, a large, detailed mosaic floor design is visible. It features a snake with a patterned body and a flower with multiple petals, both rendered in a mosaic style using various shades of brown, gold, and white. The snake's body is coiled, and its head is raised. The flower is positioned near the snake's tail. The floor is highly polished, reflecting the light from the windows and the intricate details of the mosaic. In the background, a dining table and chairs are visible, suggesting a restaurant or a formal dining area. The overall atmosphere is one of luxury and sophisticated design.



SICIS

SiciStone Collection

La semplicità dei pavimenti musivi romani di età imperiale (I-V sec. d.C.) si può spiegare soltanto con l'introduzione di una tecnica pavimentale assai più raffinata e pregiata del tessellato. Pare infatti che l'opus sectile abbia ad un certo punto soppiantato i classici pavimenti a mosaico di ispirazione ellenistica relegandoli ad ambienti secondari nelle abitazioni di lusso. In effetti nell'opus sectile i pezzi di marmo, tagliati nella forma prescelta, sono accostati gli uni agli altri senza lasciare uno spazio intermedio, contrariamente a quanto accade nell'opus tessellatum; la posa in opera di questo tipo di pavimenti richiede, dunque, l'intervento di maestranze specializzate e tempi più lunghi comportando, di conseguenza, costi di realizzazione maggiori. Il suo utilizzo, perciò, oltre a sottolineare l'importanza dell'ambiente in cui si trova, diviene un segno del ceto economico e sociale elevato del committente. Inoltre, anche il lavoro del pictor imaginarius, il maestro che disegna il decoro e stabilisce i materiali da impiegare, si fa via via più complesso e minuzioso per permettere poi al pictor tessellarius di realizzare un'opera perfetta.

Plinio il Vecchio, nel Libro XXXVI della sua Naturalis Historia parla dei Sectilia chiamandoli alla greca 'lithostrota': mosaico battuto o cocciopesto, con inserti di lastre di pietre colorate e di marmi policromi, di forme sia irregolari che geometriche, con disposizione ora regolare ora casuale.

Purtroppo, la facilità di reimpiego dei marmi preziosi dei Sectilia rispetto ai tessellati e l'ingordigia di cui sono stati oggetto per secoli, dall'Alto Medioevo al periodo cosmatesco fino ad arrivare ai giorni nostri, spiega la scarsità di esempi di opus sectile nei ritrovamenti di epoca romana imperiale, fatta eccezione per alcuni siti particolarmente significativi come Villa Adriana a Tivoli o zone termali dell'area romana e napoletana, in cui esso veniva impiegato non solo in soluzioni pavimentali ma anche parietali (incrustatio).

Ecco perché SICIS ha voluto riproporre e riportare in vita un'arte millenaria di cui, a causa delle frequenti spoliazioni, si è pressoché persa la memoria, rivisitando e arricchendo con la creatività del presente i disegni antichi. Grazie a tecnologie produttive d'avanguardia, ecco che veri e propri ricami d'oro e smalto prendono forma su delicate trame in onice e marmo.

The simplicity of the mosaic pavements dated from Roman imperial times (I-V century A.D.) can be explained only through the introduction of a flooring technique much more refined and precious than the tessellated one. Indeed, it seems that the opus sectile had at one point foregone the Grecian inspired classic mosaic pavements and relegated it to lesser important areas of the luxury homes. Actually in the opus sectile the marble pieces cut in the chosen shapes, are laid one next to the others without leaving an intermediate space, unlike it happens in the opus tessellatum, thus the laying of this type of floor requires the intervention of skilled masons and longer times, thus involving higher costs.

Therefore, its use became the sign of financial and social high ranking of the client in addition to highlighting the importance of the environment in which is found. Plus, the work of the pictor imaginarius, the maestro who designs the decoration and establishes the materials to use, become increasingly more complex and detailed in order then to allow the pictor tessellarius (the artist who executed floor mosaics) of achieving a perfect work.

In his XXXVI Book Naturalis Historia, Plinio il Vecchio (Pliny the Elder) talks of the Sectilia calling them with the Greek name 'lithostrota': smoothed mosaic or cocciopesto, with insertion of coloured stone and polychromatic marble tiles, with sometime regular and some other times irregular geometric forms and layouts. Unfortunately, the tendency of reutilising the precious marbles of Sectilia as compared to the tessellated ones and greediness to which they have been subjected for centuries, from Early Middle Ages to the Cosmatesque period and up to our times, justifies the shortage of examples of opus sectile in the findings from the imperial Roman times, with the exception of some especially significant sites like Villa Adriana in Tivoli or spa areas of the Roman and Neapolitan areas, in which it was utilised not just in floor solutions, but also on walls (incrustatio).

That is why SICIS has wanted to revive and bring back to life a millenary art of which, due to frequent plundering, we have almost lost memory of it, by revisiting and enriching through the modern creativity the ancient designs. Thanks to cutting edge productive technologies, here then true and real gold and enamel embroideries come to life on delicate weaves in onyx and marble.







SICIS



SICIS



SICIS



SICIS



SICIS

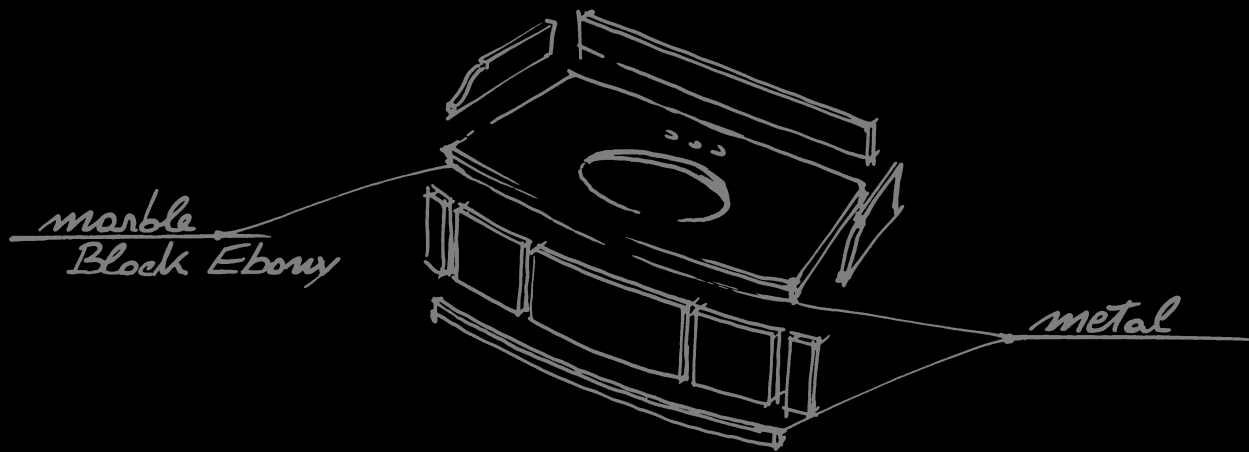

Detail - Washbasin

metal

marble Calacatta



SICIS





Marble versus water Decoration wins!

Visual

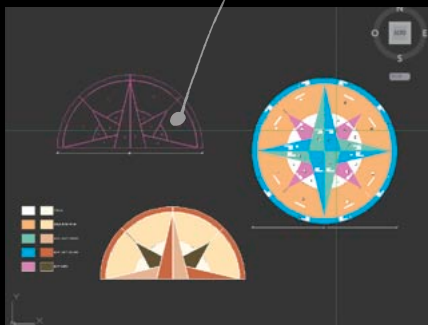

Ebony Black

*Emperador
Light and Dark*

Golden Spider

SICIS









The colors of Marble

**White
& Grey**

page 58

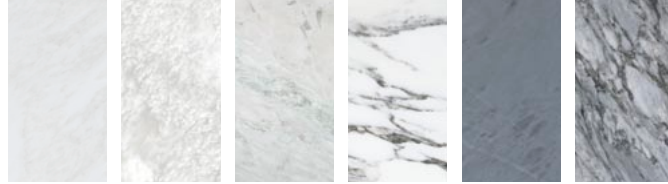

Black

page 128

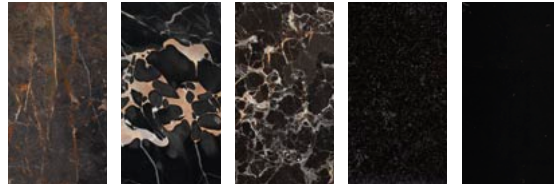

Beige

page 166



Golden

page 188

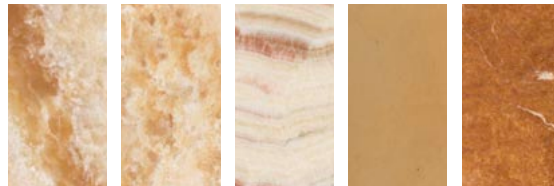

Pink

page 214



Red
page 222

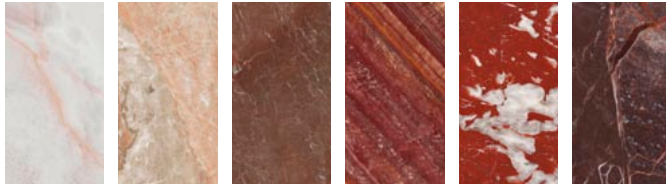

Brown
page 234

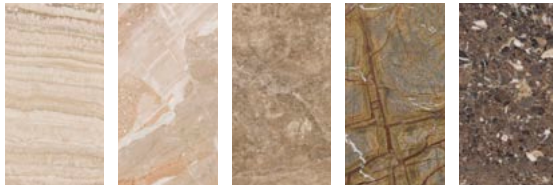

Green
page 38

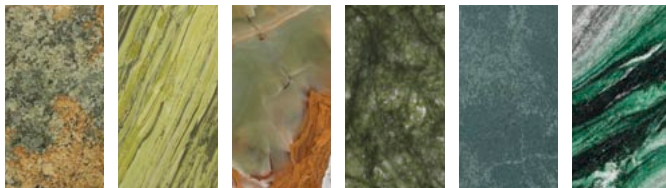

Blue
page 24

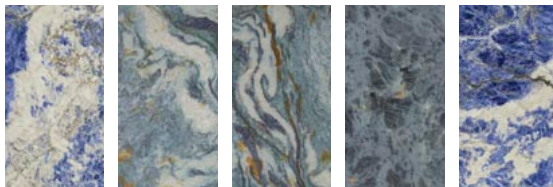

Charcoal
page 258

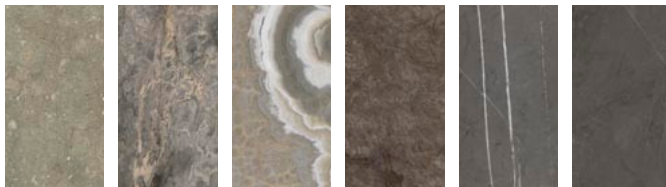

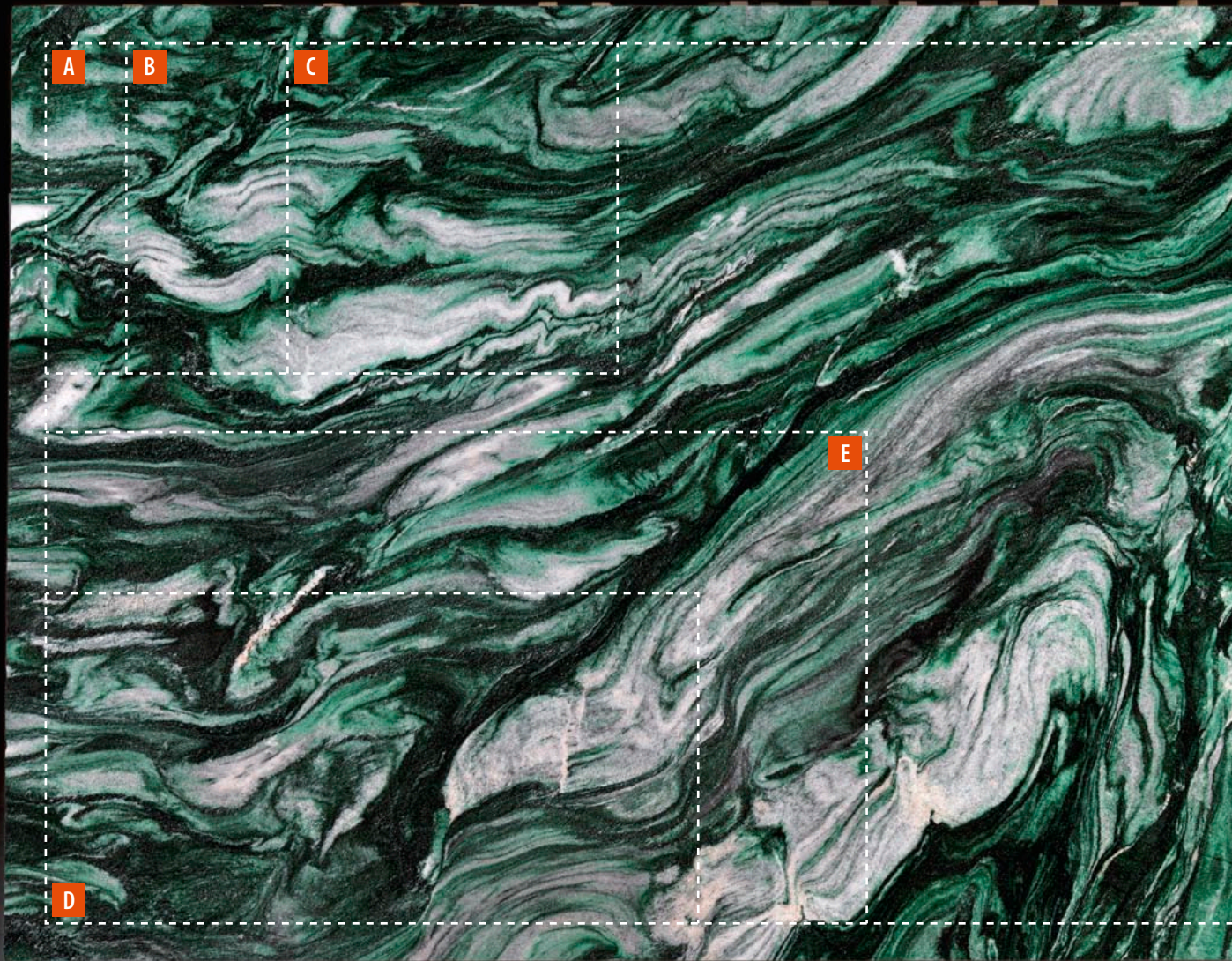

Verde Lapponia marble slab before cutting

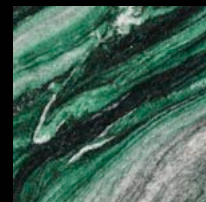
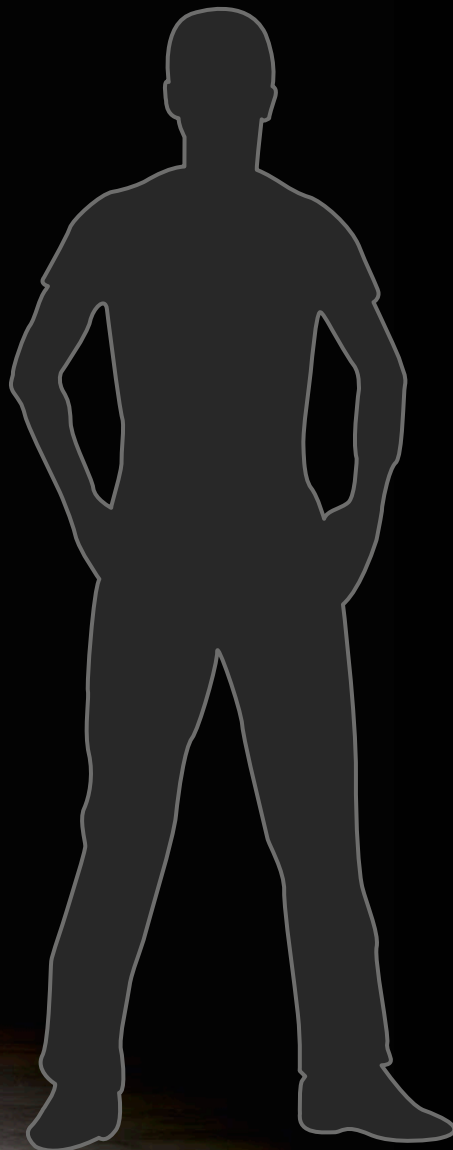

30,5 x 30,5 cm · 12" x 12"
Thickness: 1 cm · 3/8"

Item A
15 x 60 cm · 5 7/8" x 23 5/8"
Thickness: 1 cm · 3/8"

Item B
30 x 60 cm · 11 3/4" x 23 5/8"
Thickness: 1 cm · 3/8"

Item C
60 x 60 cm · 23 5/8" x 23 5/8"
Thickness: 2 cm · 3/4"

Item D
120 x 60 cm · 47 1/4" x 23 5/8"
Thickness: 2 cm · 3/4"

Item E
150 x 90 cm · 59" x 35 3/8"
Thickness: 2 cm · 3/4"

... and more

The background of the entire page is a blue marbled paper with a complex, organic pattern of veins in various shades of blue and green. A solid black rectangular box is positioned on the left side of the page, containing the word "Blue" in white text.

Blue

SICIS

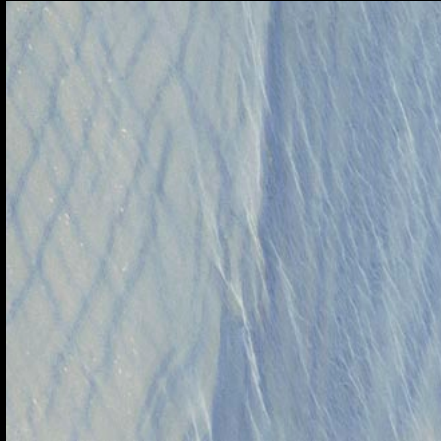

Azul Macauba

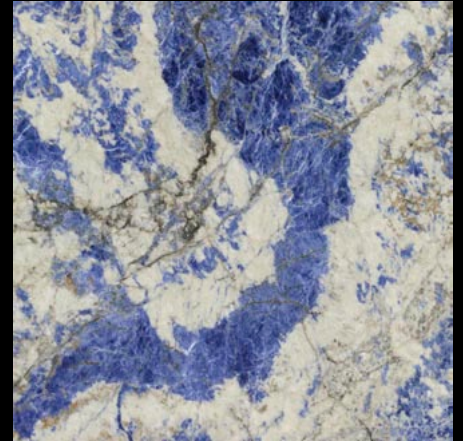

Sodalite Blue



Van Gogh



Labradorite Multicolor

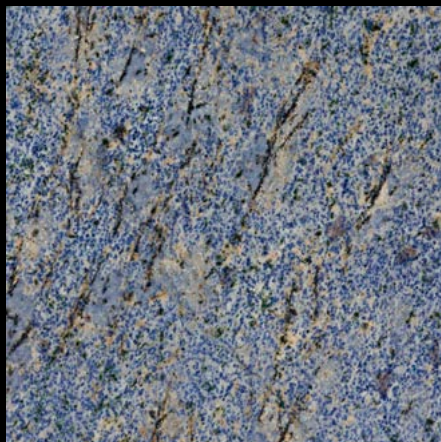

Azul Bahia



SICIS





Delicatissimum BEC2

Sodalite Blue

SICIS

Sodalite Blue

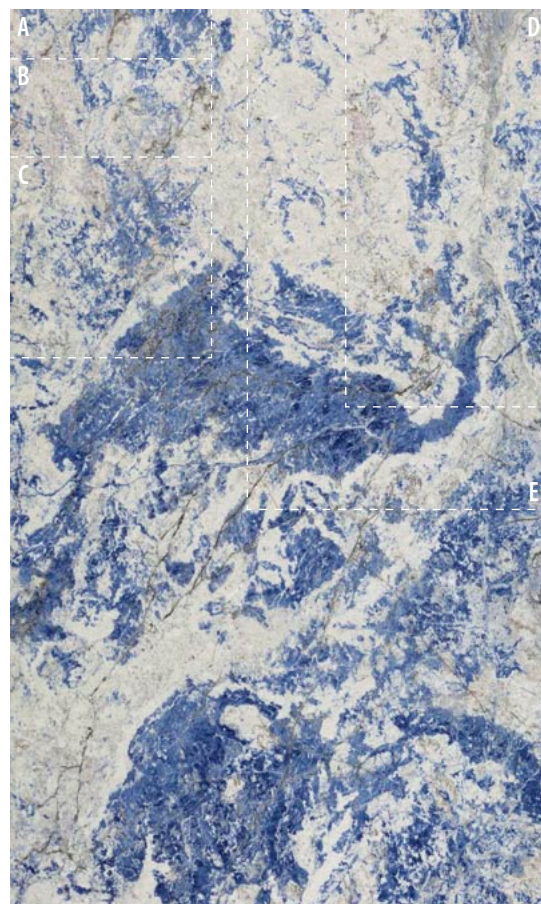
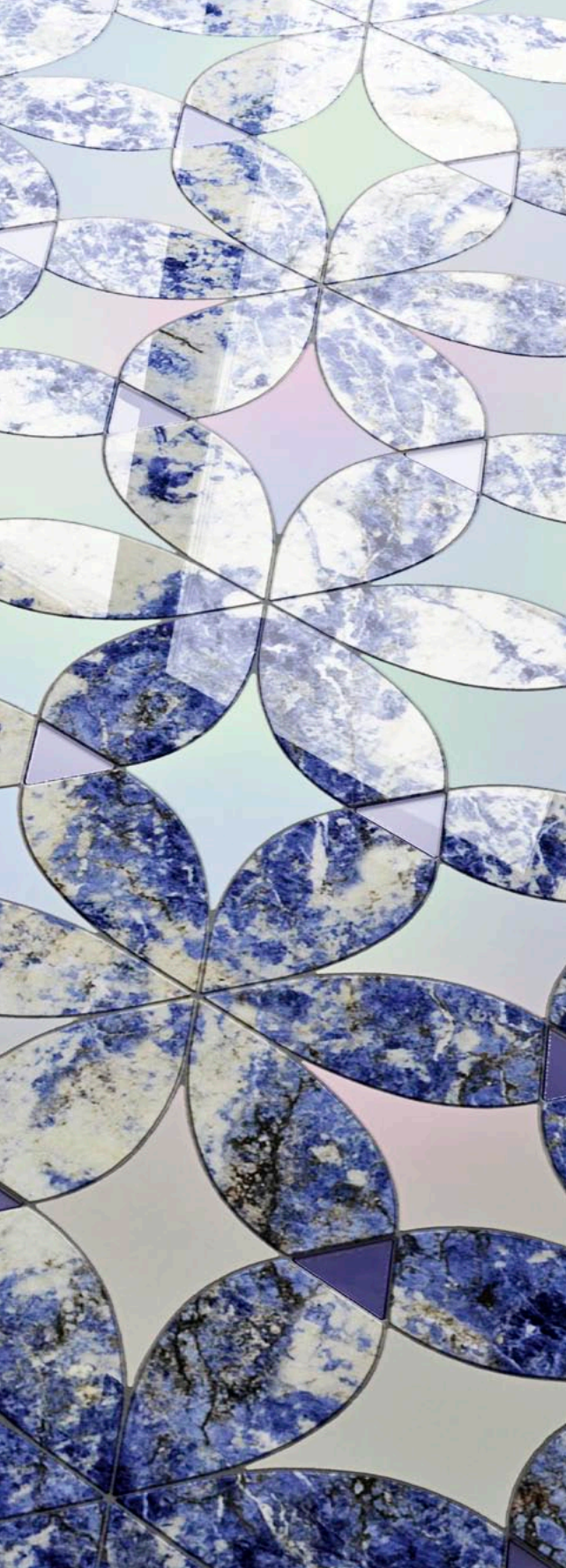

Item A
15 x 60 cm · 5^{7/8}" x 23^{5/8}"

Item B
30 x 60 cm · 11^{3/4}" x 23^{5/8}"

Item C
60 x 60 cm · 23^{5/8}" x 23^{5/8}"

Item D
60 x 120 cm · 23^{5/8}" x 47^{1/4}"

Item E
90 x 150 cm · 35^{3/8}" x 59"

... and more

Cetrix White



SICIS

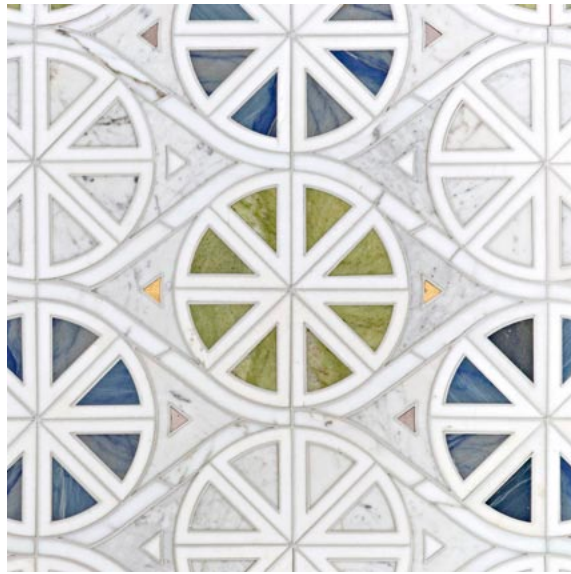

Cetrix White

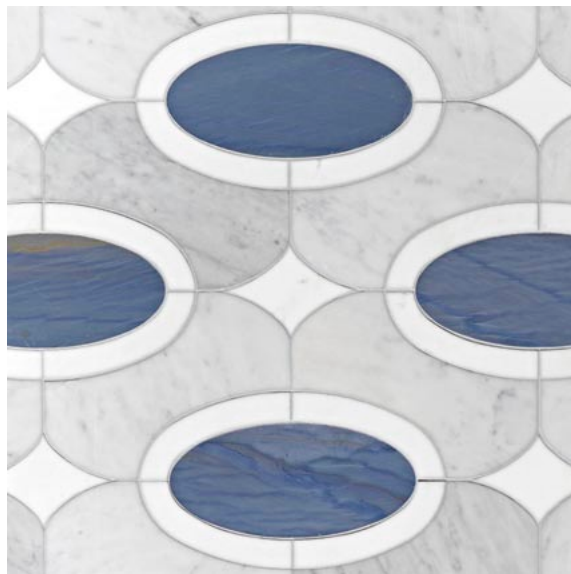

Seleris Azul



Complementary Product
Bianco Carrara · 61 x 61 cm · 24" x 24"



Complementary Product
Bianco Carrara · 61 x 30,5 cm · 24" x 12"

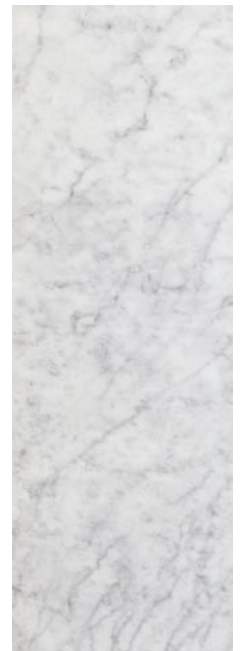

Complementary Product
Bianco Carrara · 30,5 x 92,3 cm · 12" x 36^{3/8}"



Randal Azul



Primavera Astrid

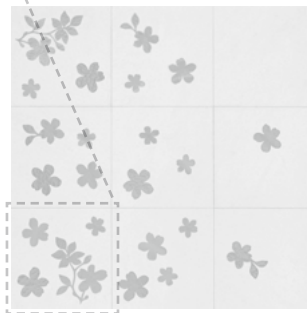

Primavera Combination
(9 pieces 45,7 x 45,7 cm · 18" x 18")
135 x 135 cm · 53 1/8" x 53 1/8"



The image displays a decorative marble pattern. The background is a light-colored, possibly white or cream, marble with subtle veining. Overlaid on this are several overlapping, teardrop-shaped leaf motifs in a dark blue-grey color. At the points where these leaves meet, there are small, circular accents in a lighter, vibrant blue. The overall aesthetic is elegant and modern.

Randal Azul

SICIS

Toral Blue

SICIS

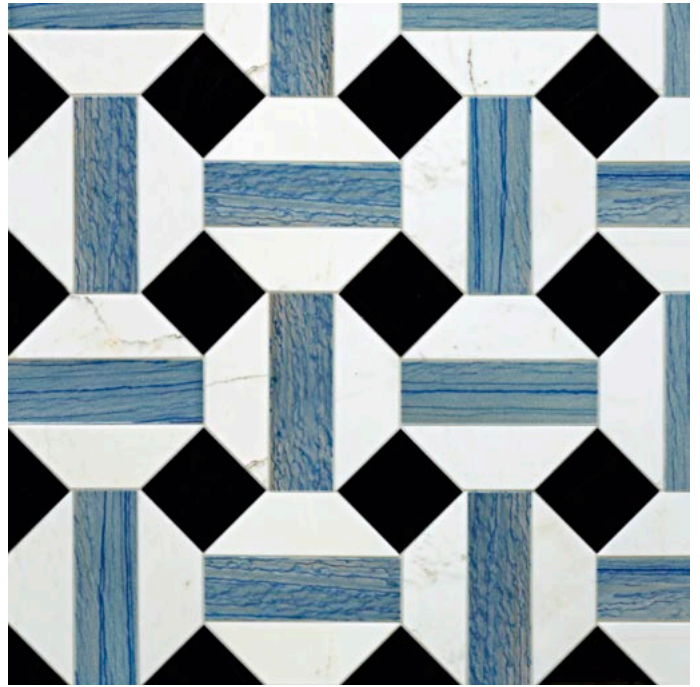

Toral Blue

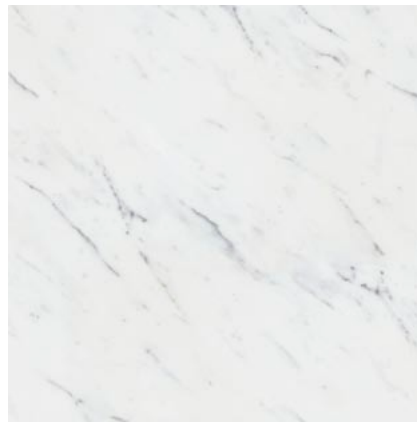

Complementary Product
Statuario · 61 x 61 cm · 24" x 24"



Complementary Product
Statuario · 61 x 30,5 cm · 24" x 12"

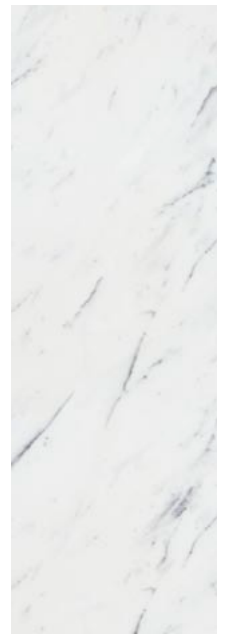

Complementary Product
Statuario
30,5 x 92,3 cm · 12" x 36^{3/8}"



SICIS

Andel Blue



Andel Blue

Green



Onice Blue



Onice Verde Light



Onice Verde Dark



Verde Namibia



Bamboo Green

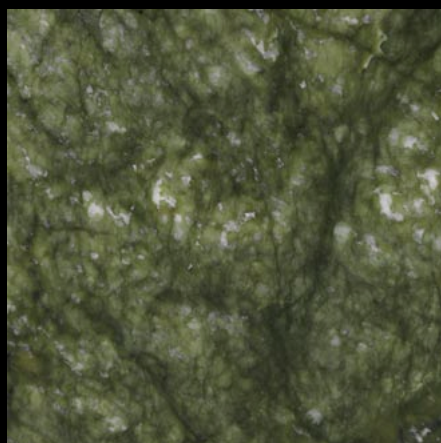

Verde Giada

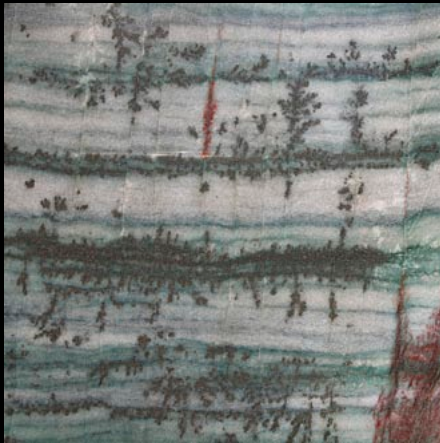

Arlecchino



Onice Smeraldo

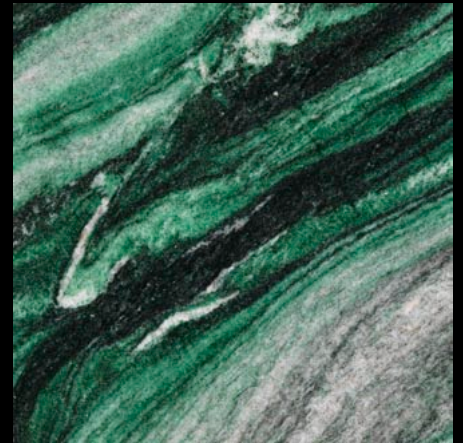

Verde Lapponia



Antique Green



Verde Luna



Olive



Verde





SICIS



Verde
Giada



SICIS



Dralis Green
Verde Giada

SICIS

Verde Giada

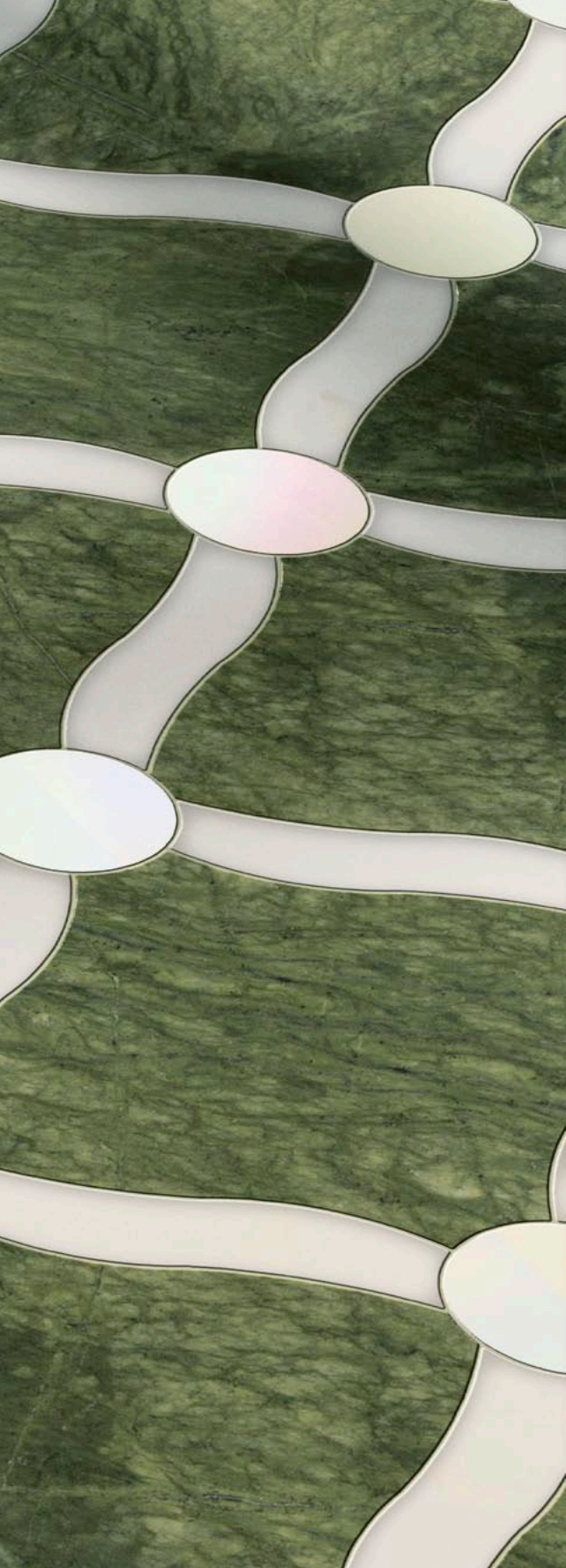

Item A
15 x 60 cm · 5^{7/8}" x 23^{5/8}"

Item B
30 x 60 cm · 11^{3/4}" x 23^{5/8}"

Item C
60 x 60 cm · 23^{5/8}" x 23^{5/8}"

Item D
60 x 120 cm · 23^{5/8}" x 47^{1/4}"

Item E
90 x 150 cm · 35^{3/8}" x 59"

... and more

Celosin Green



SICIS

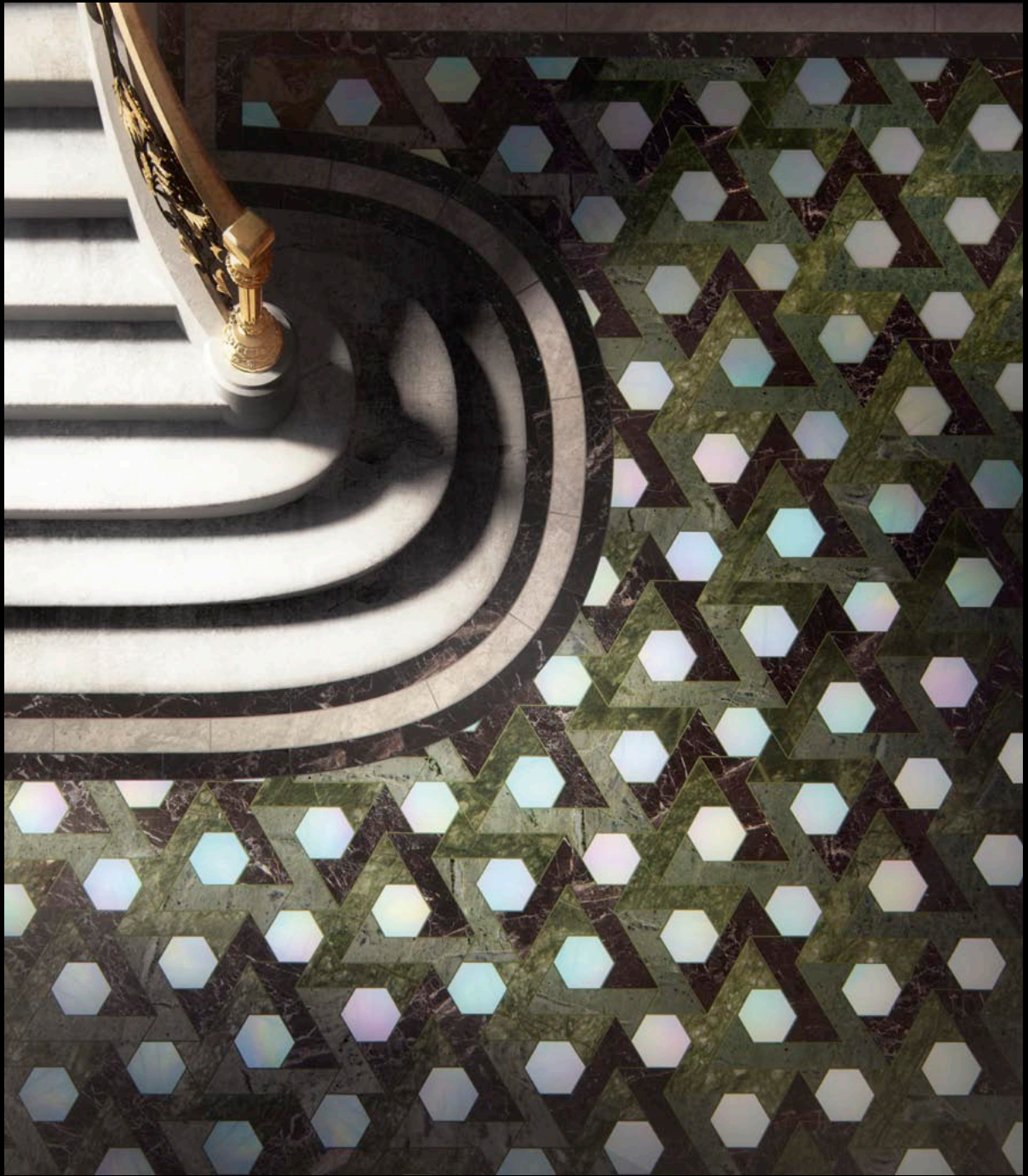



Iberis Green
Verde Lapponia

SICIS

Verde Lapponia



Item A
15 x 60 cm · 5 ⁷/₈" x 23 ⁵/₈"

Item B
30 x 60 cm · 11 ³/₄" x 23 ⁵/₈"

Item C
60 x 60 cm · 23 ⁵/₈" x 23 ⁵/₈"

Item D
60 x 120 cm · 23 ⁵/₈" x 47 ¹/₄"

Item E
90 x 150 cm · 35 ³/₈" x 59"

... and more

Jupiter Green

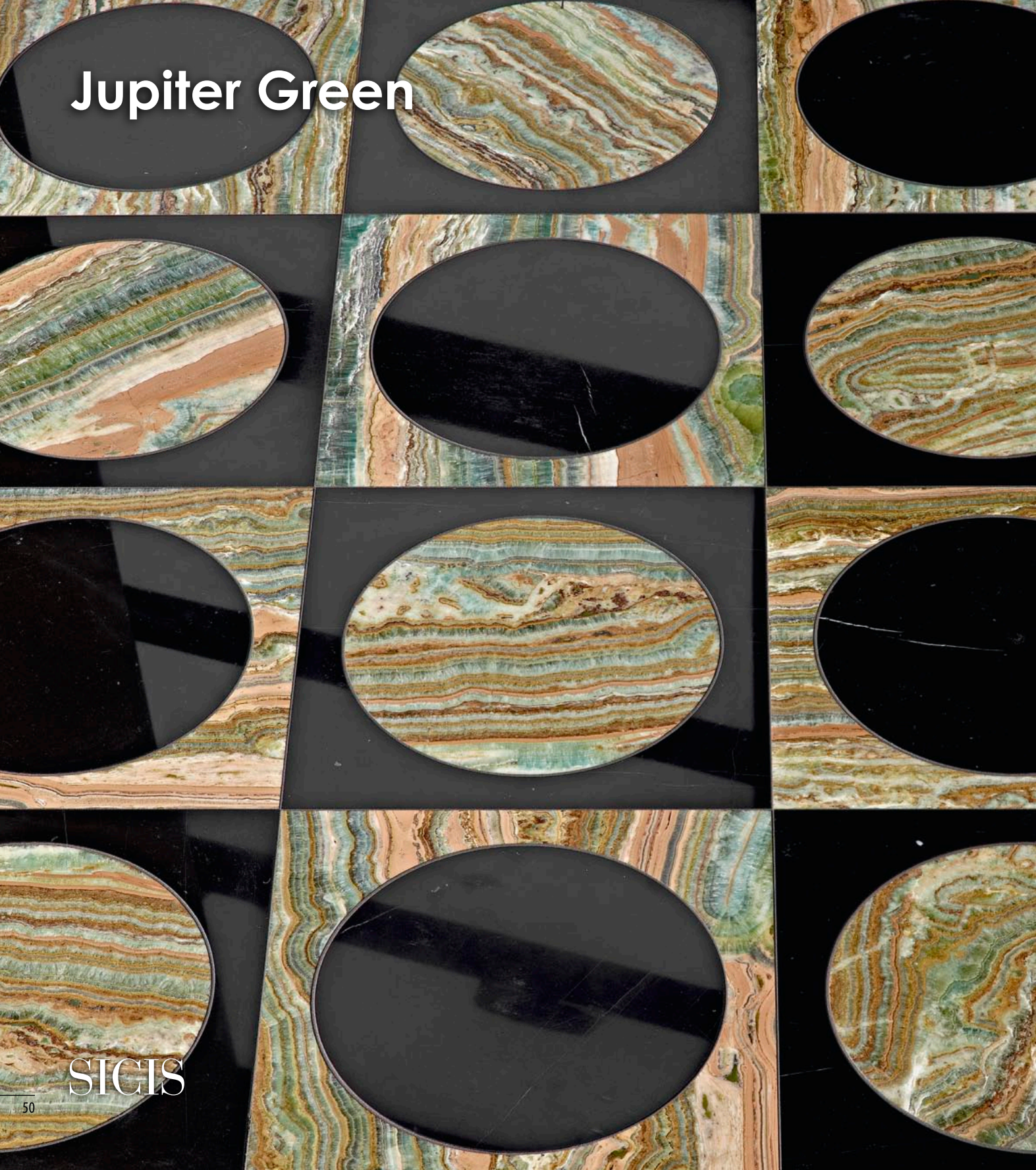

SIGIS

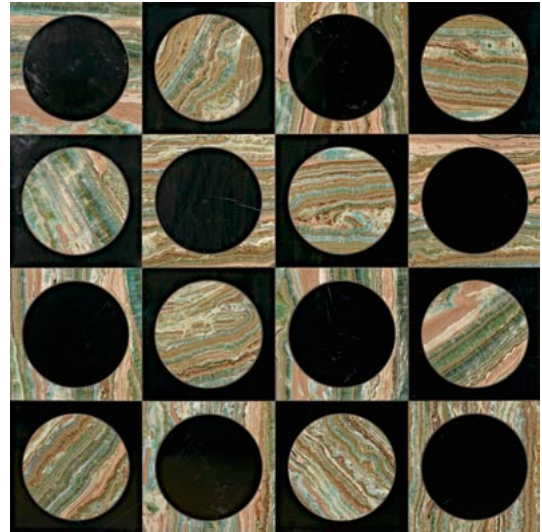
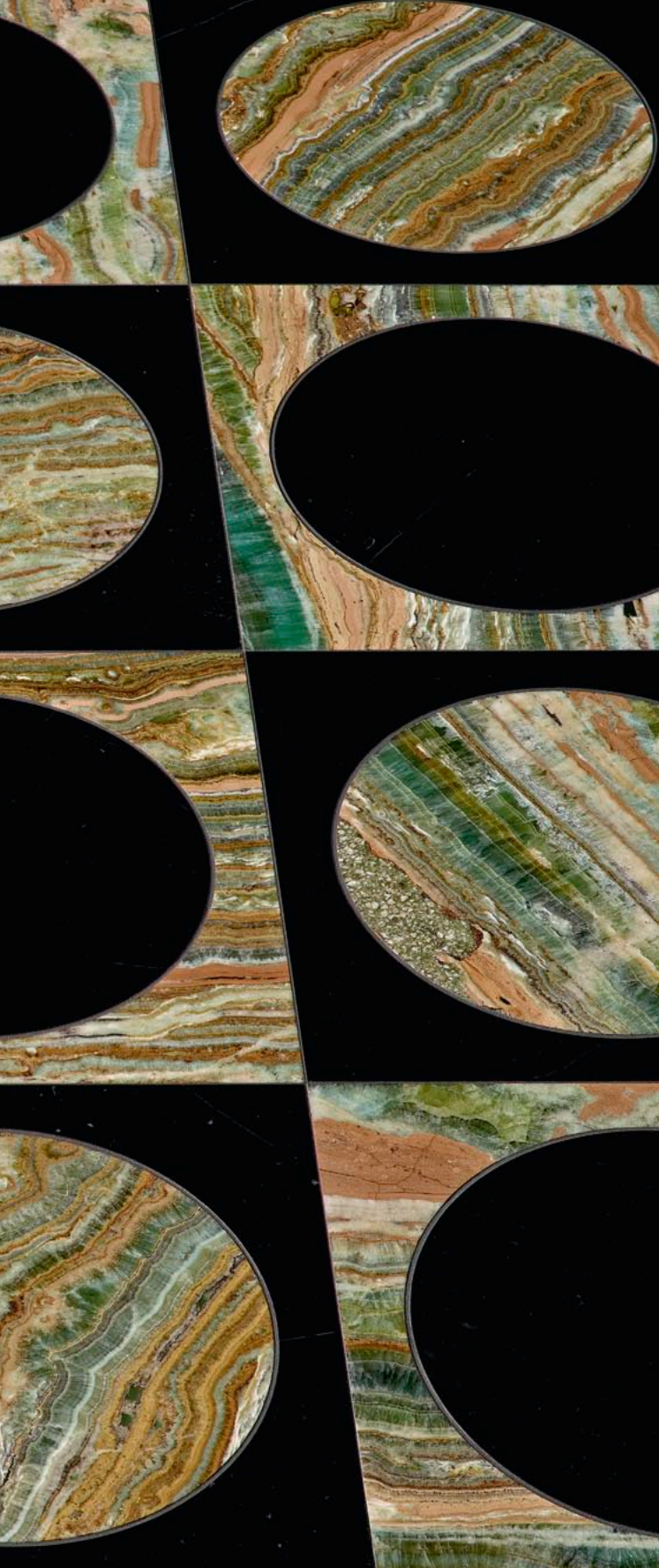

Jupiter Green



Jalisco Green

Olson Green Onice Verde Dark

SICIS

Onice Verde Dark



Item A
15 x 60 cm · 5^{7/8}" x 23^{5/8}"

Item B
30 x 60 cm · 11^{3/4}" x 23^{5/8}"

Item C
60 x 60 cm · 23^{5/8}" x 23^{5/8}"

Item D
60 x 120 cm · 23^{5/8}" x 47^{1/4}"

Item E
90 x 150 cm · 35^{3/8}" x 59"

... and more



Tolox Green

SICIS

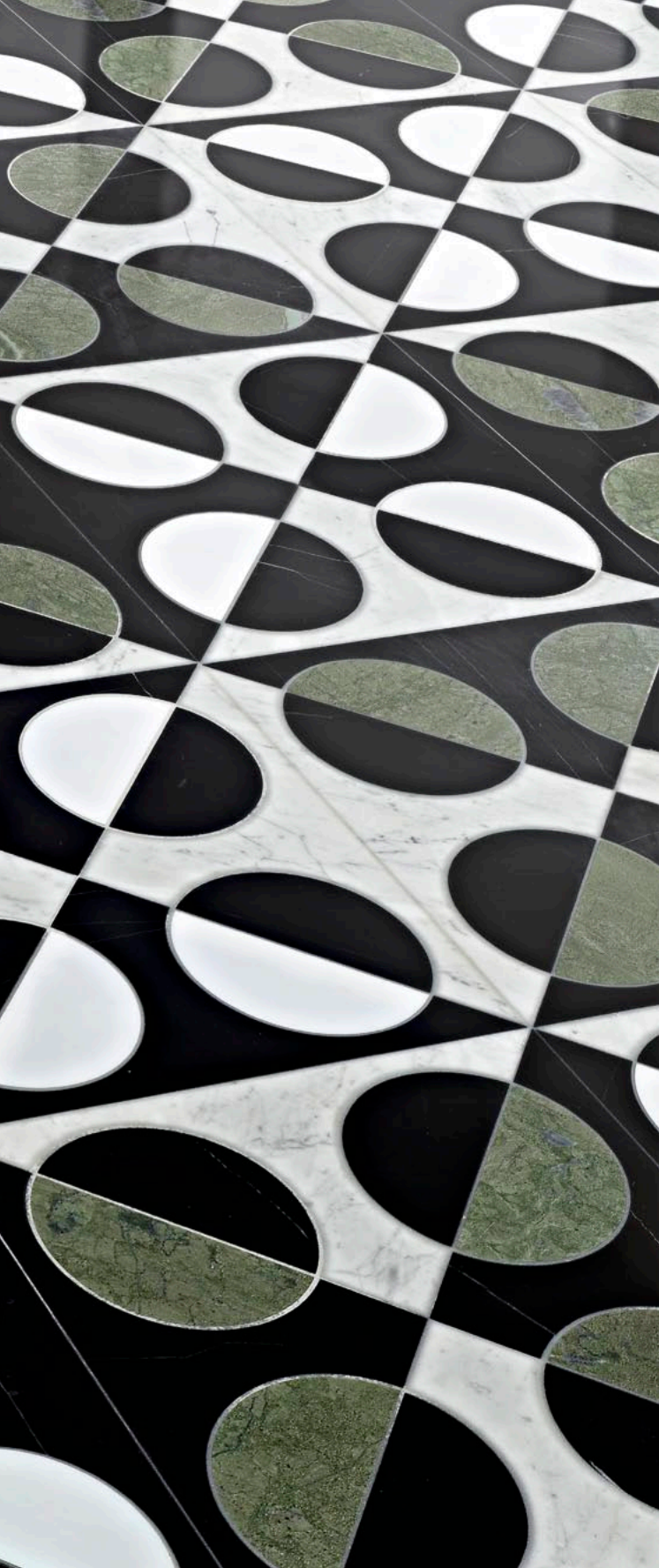

Tolox Green



Losanga Green

Salasco Green



SICIS



Salasco Green



Thassos



Bianco Namibia



Calacatta

White & Grey



Bianco Sivec



Alba Chiara



Statuario



Aghia Marina

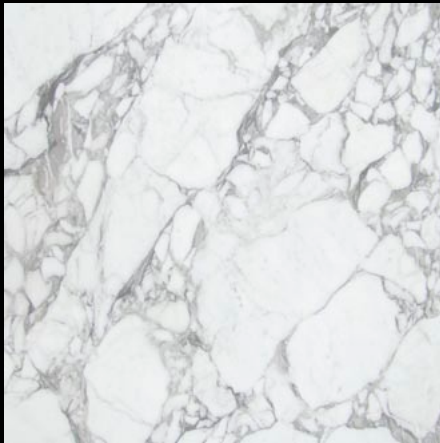

Calacatta Vagli



Statuarietto



Arabescato Carrara



Bianco Americano



Bianco Carrara



Bardiglio



Bardiglio Orientale



Bardiglio Imperiale



Bardiglio







Bianco Namibia



SICIS



SICIS

Olson Ruby

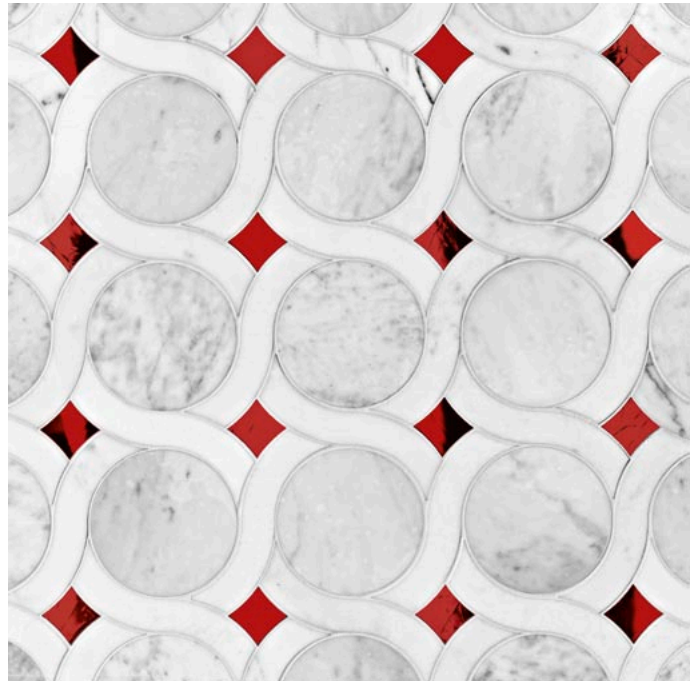

Olson Ruby

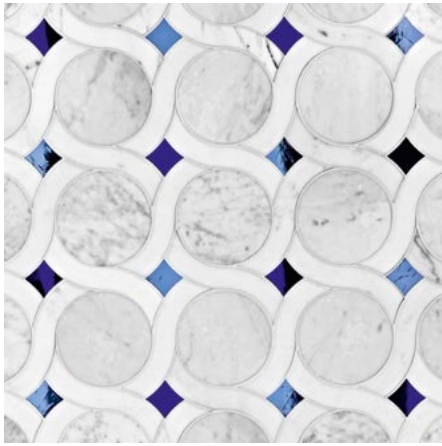

Olson Blue



Olson Grey

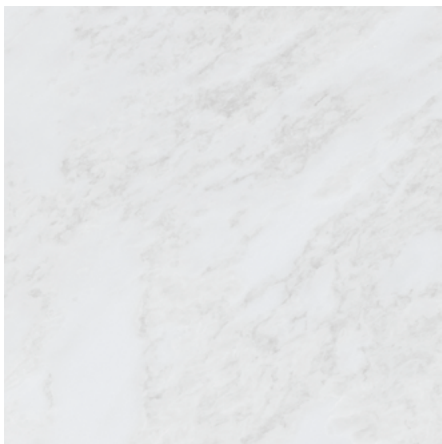

Bianco Namibia





Olson Blue

SICIS



Olson Irid
Bianco Namibia

SICIS



Vanessa

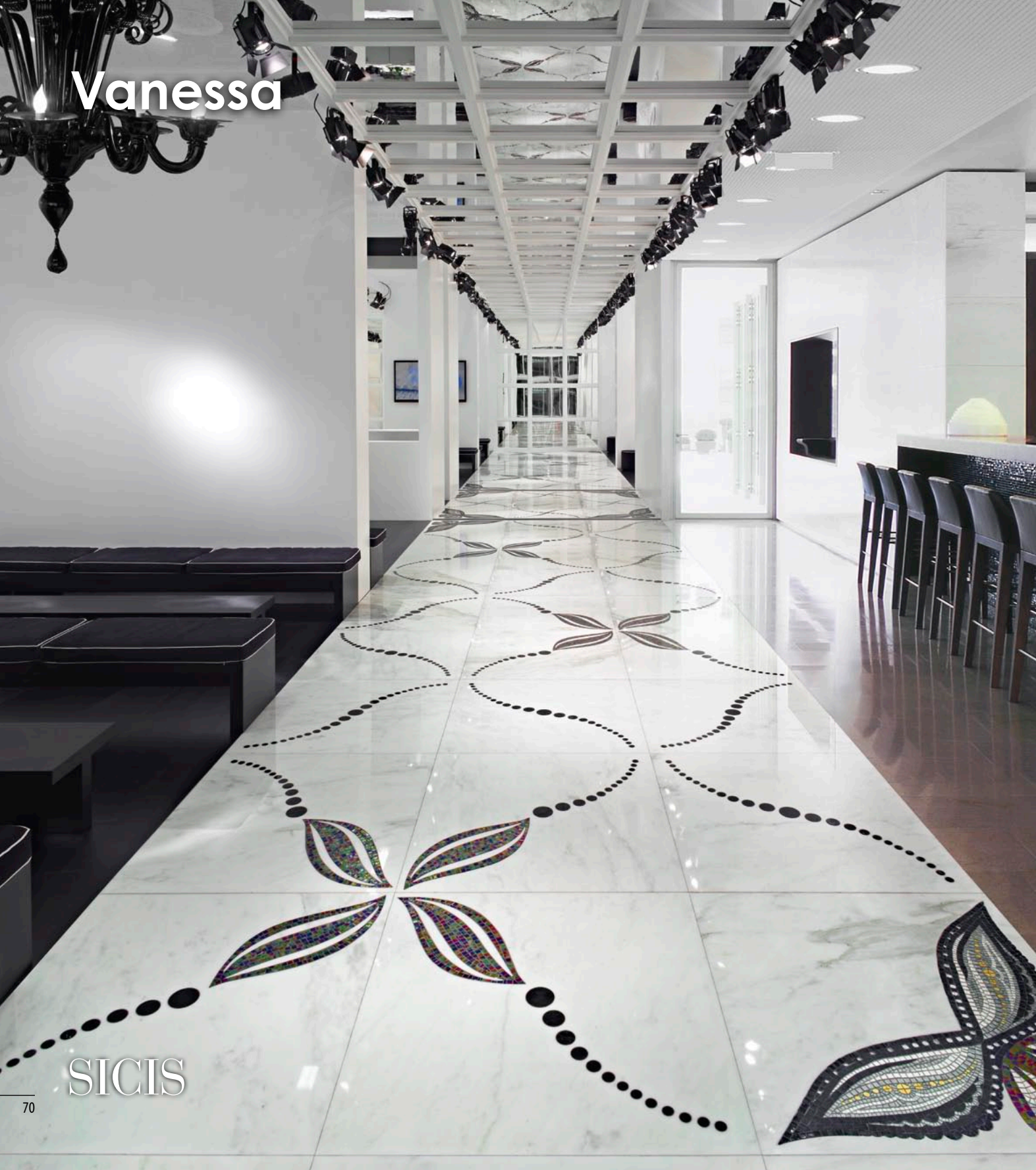

SICIS



Vanessa
Module A
90 x 90 cm
35 3/8" x 35 3/8"

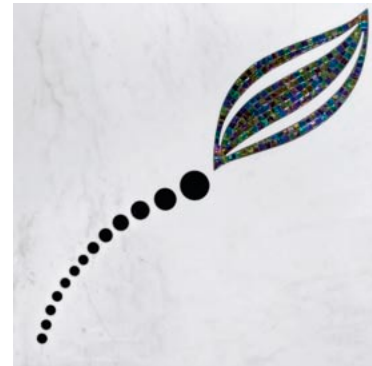

Vanessa
Module B
90 x 90 cm
35 3/8" x 35 3/8"

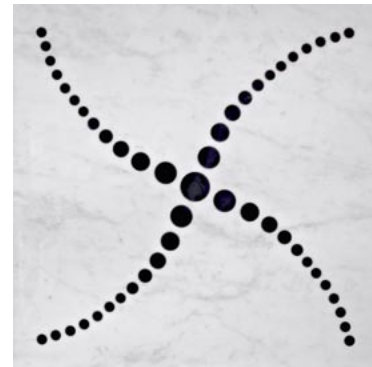

Vanessa
Module C
90 x 90 cm
35 3/8" x 35 3/8"



Vanessa
Module D
90 x 90 cm
35 3/8" x 35 3/8"

Qubeck

SICIS

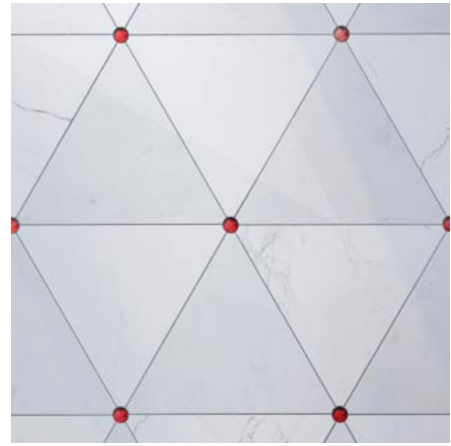
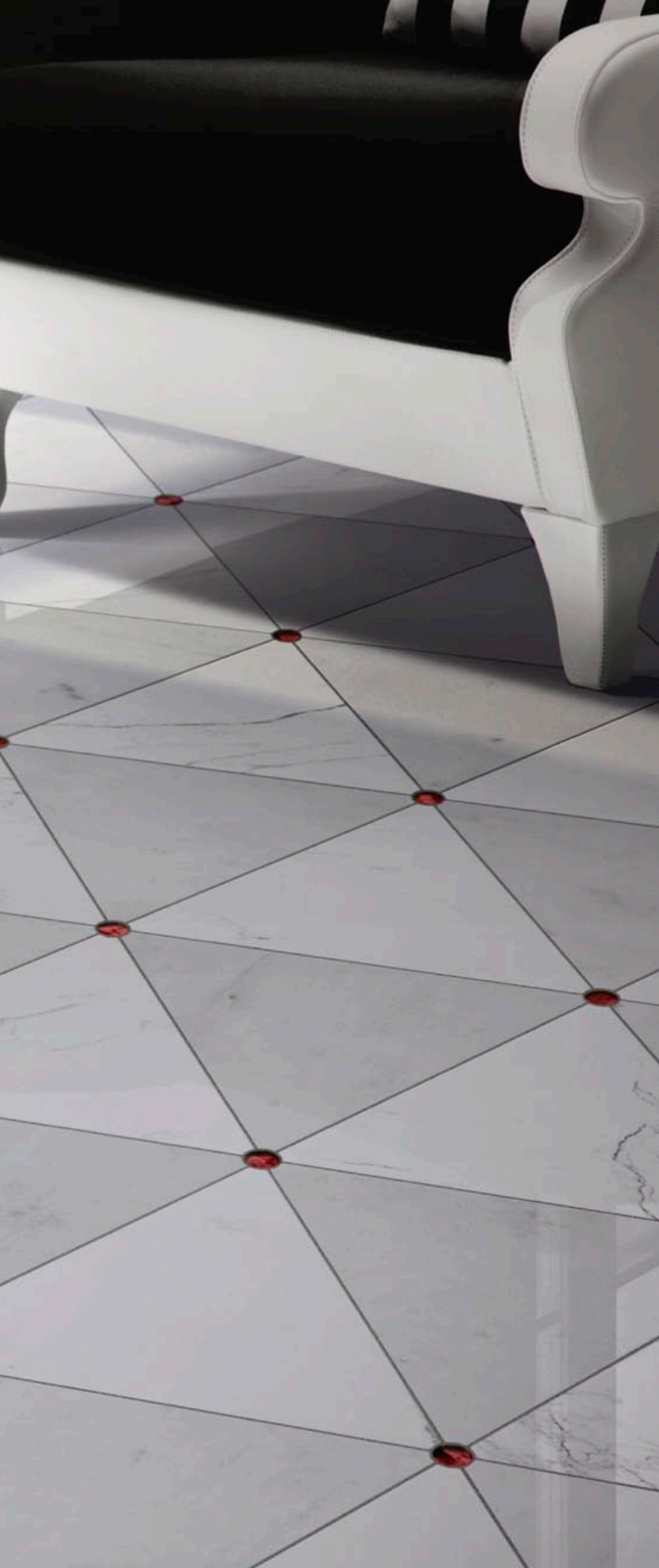

Qubeck

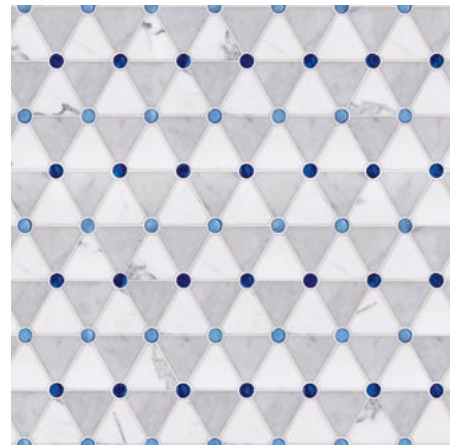

Qubeck Small Grey

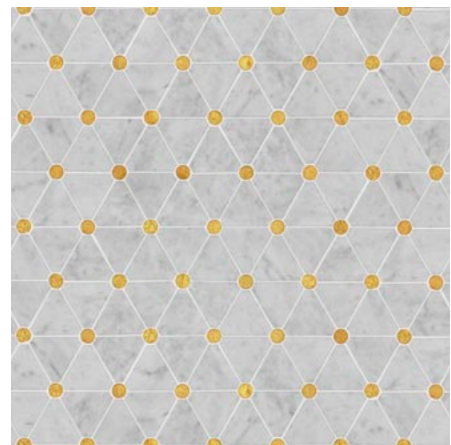

Qubeck Small Gold

Macchia Aperta





HOTEL
PRINCIPE DI SABOTA
Milano

HOTEL
PRINCIPE DI SABOTA
Milano

SICIS

Erbolarius Americano

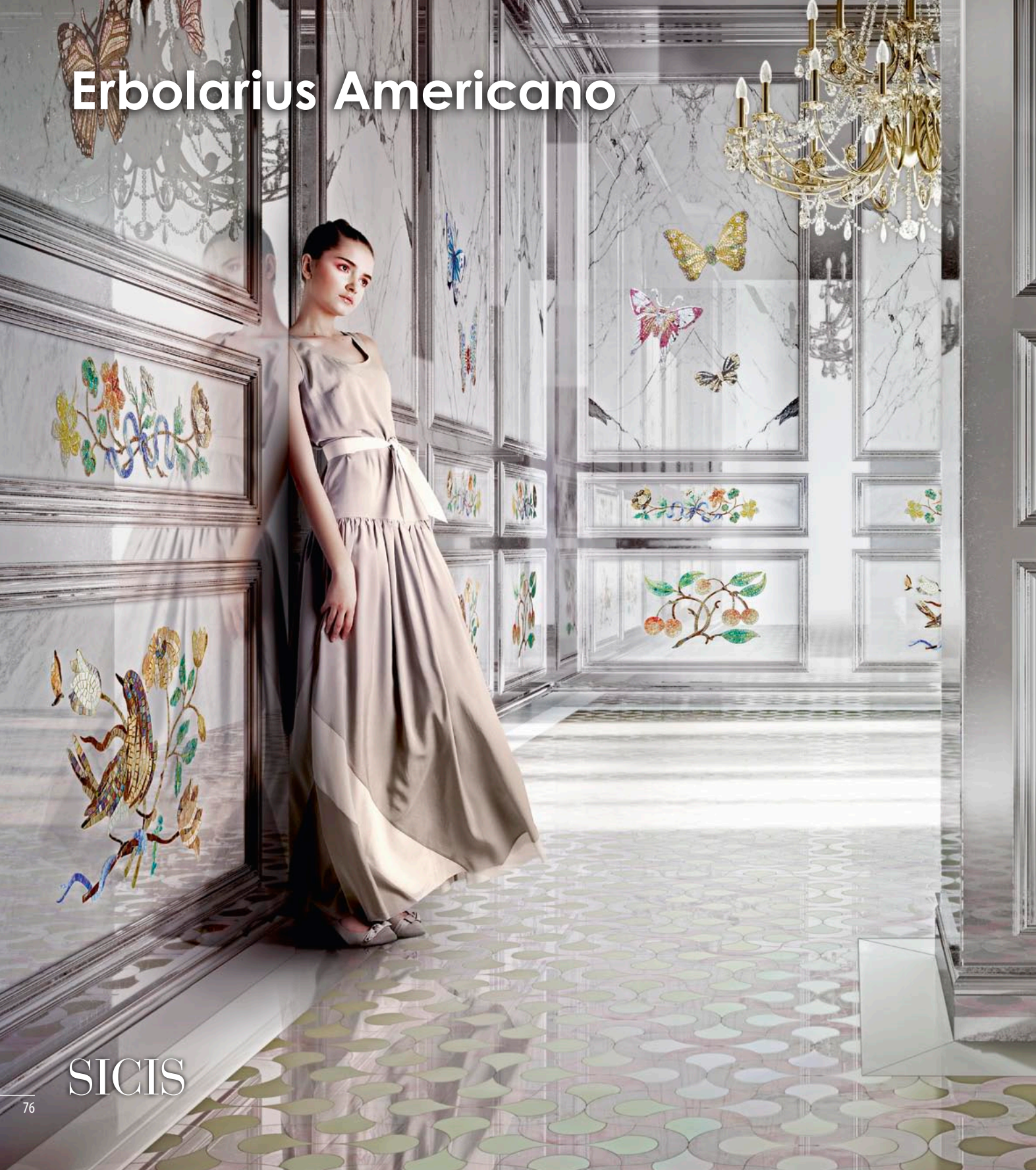

SICIS



Erbolarius Americano 1
48,7 x 32,9 cm · 19 1/8" x 13"



Erbolarius Americano 2
50,2 x 36,7 cm · 19 3/4" x 14 1/3"



Erbolarius Americano 3
86,8 x 58,3 cm · 34 1/4" x 23"



Erbolarius Americano 4
92,5 x 24,4 cm · 36 3/8" x 9 5/8"

Misure riferite al solo mosaico.
Measures are referred to mosaic only.

Gilius White



SICIS



Gilius White



Gilius Grey



Complementary Product
Bianco Carrara · 61 x 61 cm · 24" x 24"

Delicatissimum WHC



SICIS

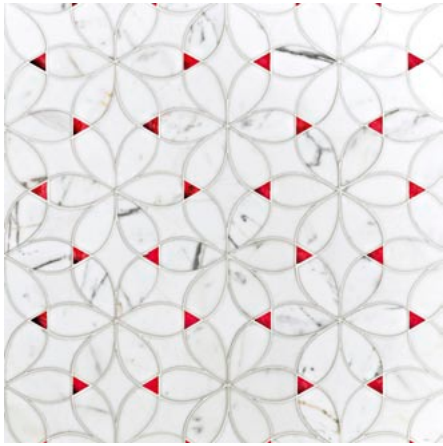

Delicatissimum WHC

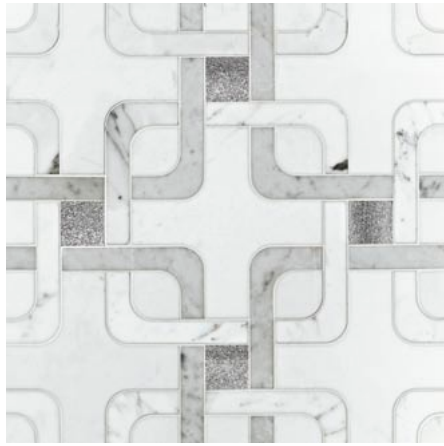

Laberiz White



Feras GR



Delicatissimum WH

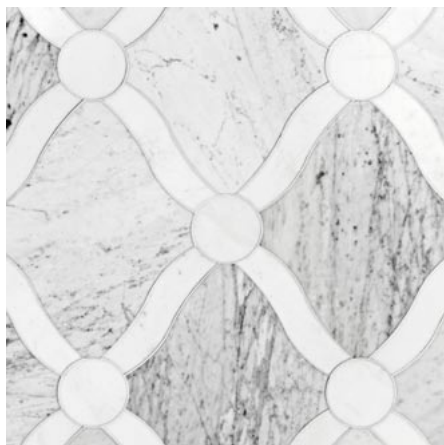

Dralis White



Feras WH



Serpentine White

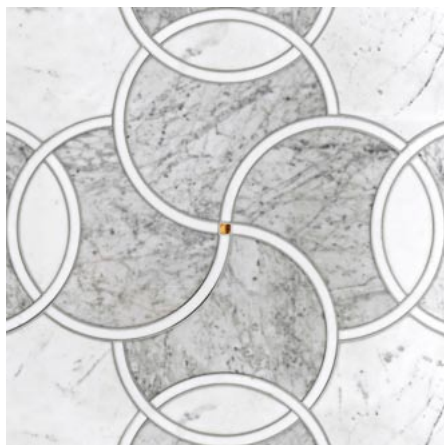

Dalisa Grey



Alia White

Palladiana B&W



Palladiana B&W



Courtesy of Sushisamba (London)



Gemstones Bianco Sivec



SICIS



Gemstone 1A Small
16,9 x 16,4 cm · 6 5/8" x 6 1/2"

Gemstone 1A Big
24,1 x 23,4 cm · 9 1/2" x 9 1/4"



Gemstone 1B Small
16,9 x 16,4 cm · 6 5/8" x 6 1/2"

Gemstone 1B Big
24,1 x 23,4 cm · 9 1/2" x 9 1/4"



Gemstone 5A Small
Ø 13,4 cm · Ø 5 1/4"

Gemstone 5A Big
Ø 19,2 cm · Ø 7 1/2"



Gemstone 2A Small
16,9 x 12,4 cm · 6 5/8" x 4 7/8"

Gemstone 2A Big
24,1 x 17,7 cm · 9 1/2" x 7"



Gemstone 3A Small
14,4 x 11,4 cm · 5 5/8" x 4 1/2"

Gemstone 3A Big
20,6 x 16,3 cm · 8 1/8" x 6 3/8"



Gemstone 4A Small
10,4 x 10,4 cm · 4 1/8" x 4 1/8"

Gemstone 4A Big
14,9 x 14,9 cm · 5 7/8" x 5 7/8"



Gemstone 2B Small
16,9 x 12,4 cm · 6 5/8" x 4 7/8"

Gemstone 2B Big
24,1 x 17,7 cm · 9 1/2" x 7"



Gemstone 3B Small
14,4 x 11,4 cm · 5 5/8" x 4 1/2"

Gemstone 3B Big
20,6 x 16,3 cm · 8 1/8" x 6 3/8"



Gemstone 4B Small
10,4 x 10,4 cm · 4 1/8" x 4 1/8"

Gemstone 4B Big
14,9 x 14,9 cm · 5 7/8" x 5 7/8"

Verano
Bianco
Sivec



SICIS





Verano
Bianco Sivec

SICIS

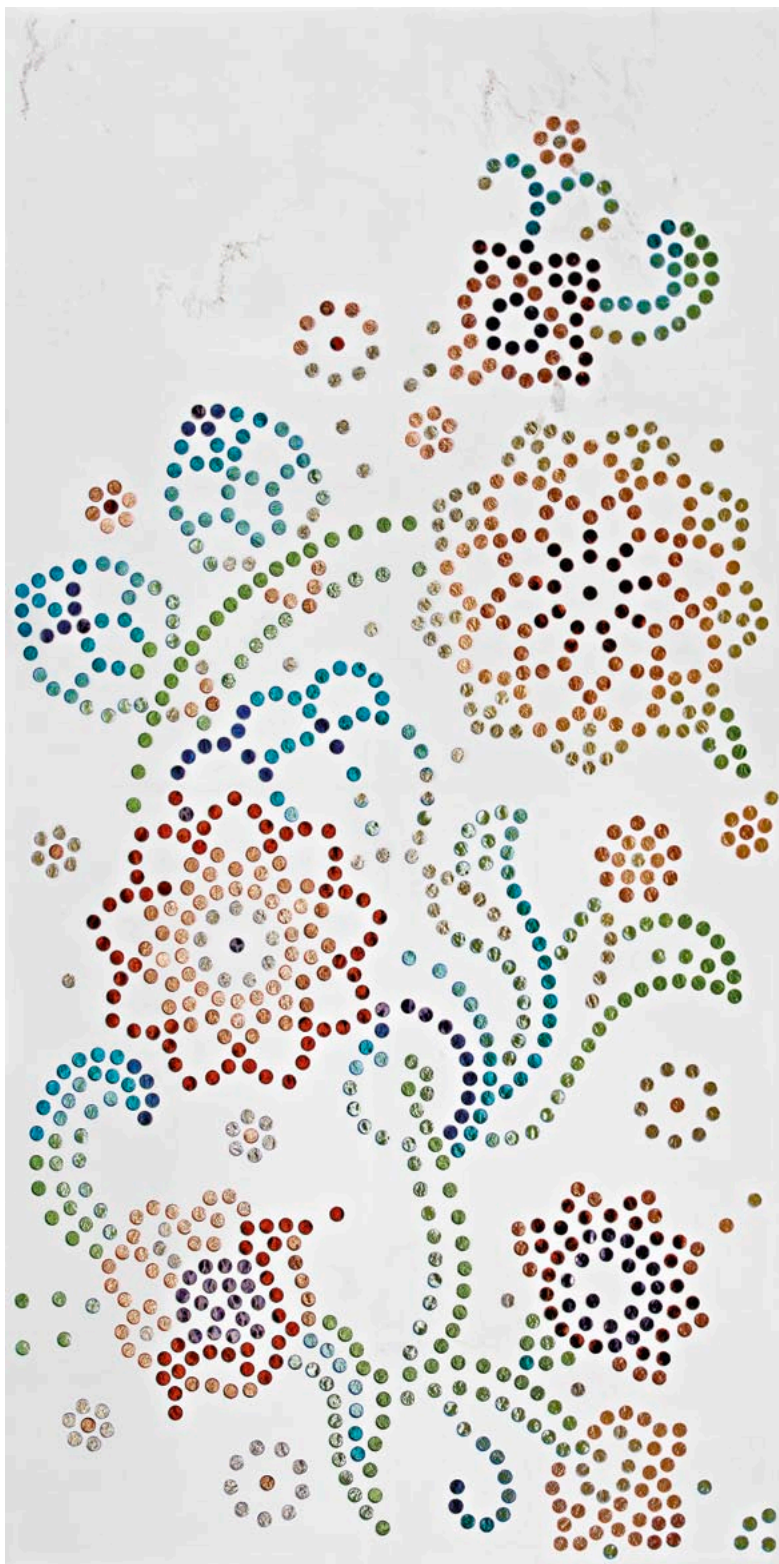

Verano
 (1 piece)
 120 x 240 cm
 47 1/4" x 94 1/2"



Verano Combination 1
 (16 pieces 60 x 60 cm · 23 5/8" x 23 5/8")
 240 x 240 cm · 94 1/2" x 94 1/2"

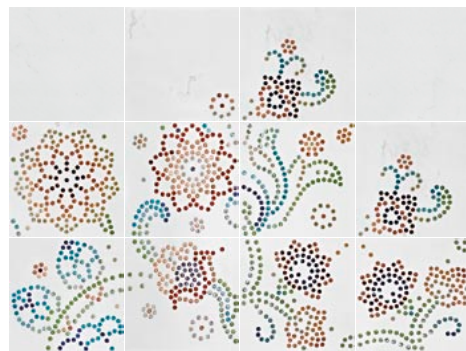

Verano Combination 2
 (12 pieces 60 x 60 cm · 23 5/8" x 23 5/8")
 240 x 180 cm · 94 1/2" x 70 7/8"

Verano Combination 3
 (8 pieces 60 x 60 cm · 23 5/8" x 23 5/8")
 120 x 240 cm · 47 1/4" x 94 1/2"

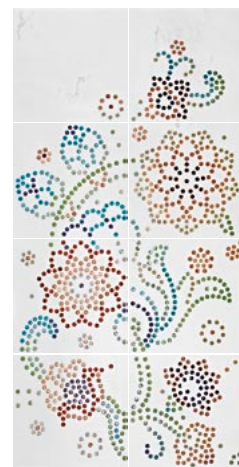

Calacatta Vagli



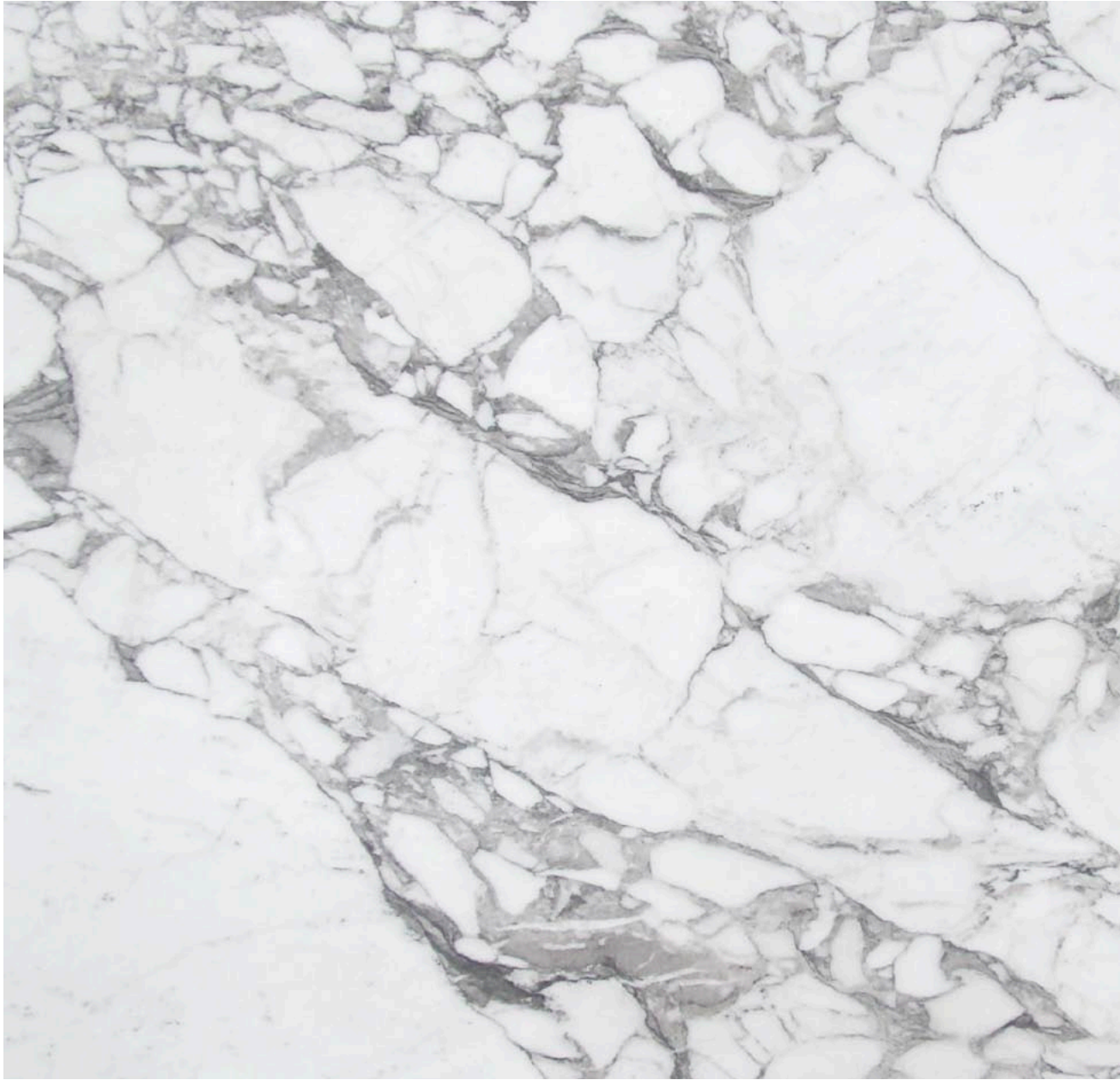

Calacatta Vagli

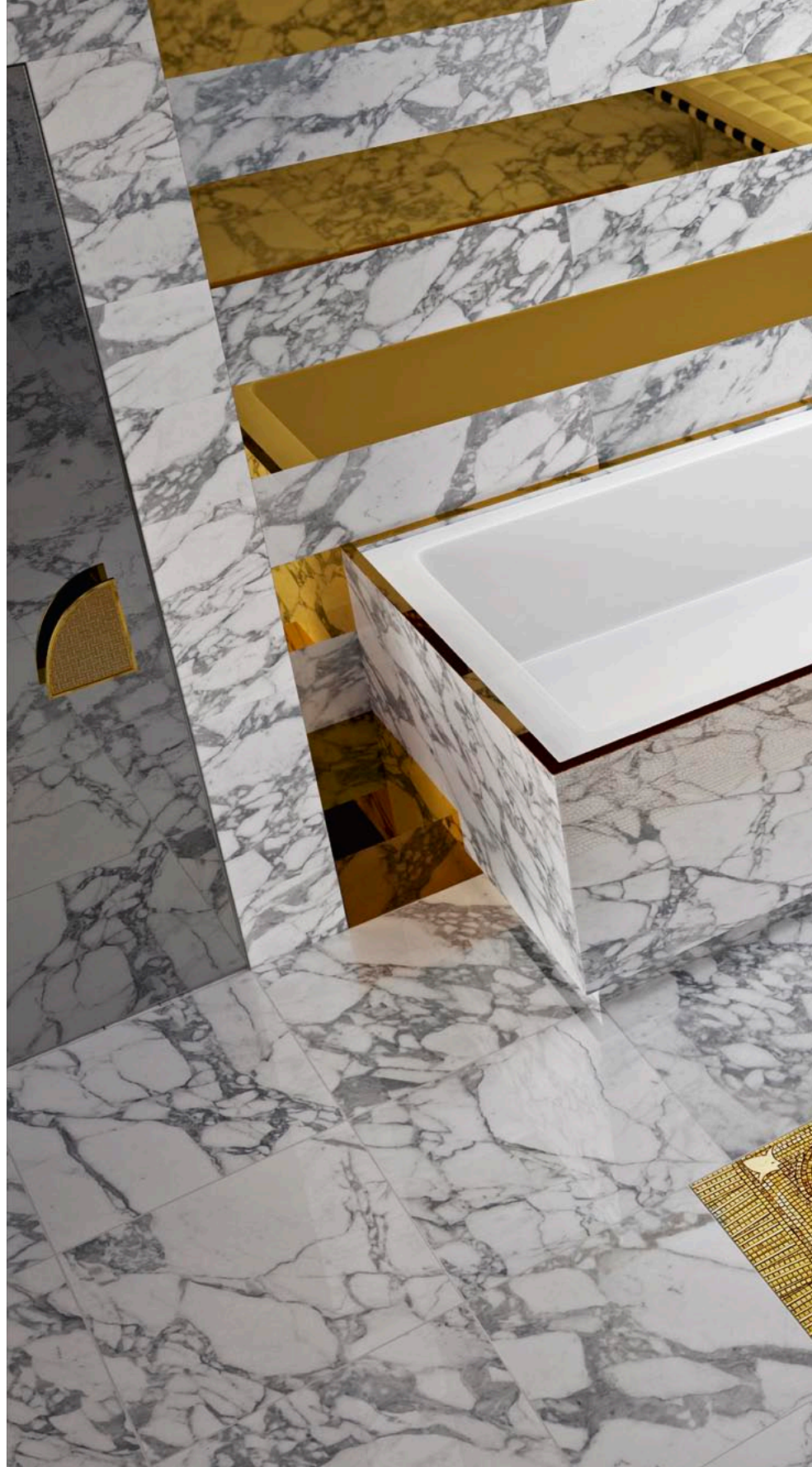

SICIS







SICIS

Bianco Carrara





SICIS



Magreb Grey



Magreb Grey



SICIS

Dragon Bianco Carrara



12

SICIS



Dragon

84,5 x 156,5 cm
33 1/4" x 61 5/8"

Misure riferite
al solo mosaico.

*Measures are referred
to mosaic only.*



SICIS

Plameny Combination

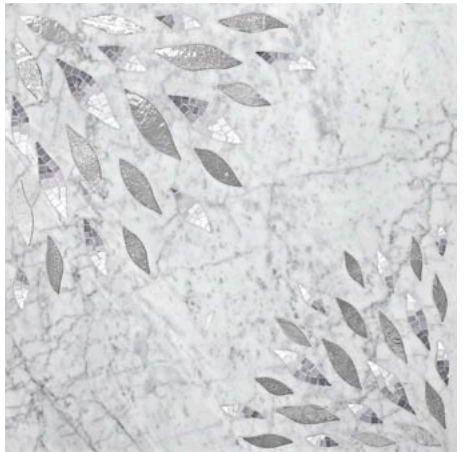
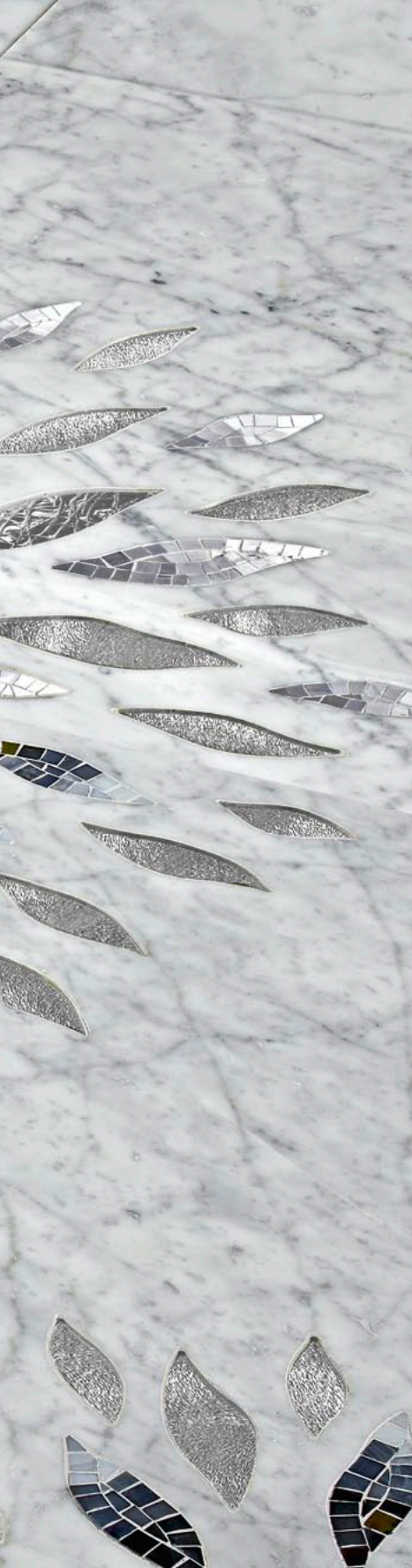

Plameny Black

Sizes: 90 x 90 cm · 35 3/8" x 35 3/8"

Plameny White

Sizes: 90 x 90 cm · 35 3/8" x 35 3/8"

Solangis Quad

Bianco Carrara



SICIS



Solangis Quad

120 x 120 cm
47 1/4" x 47 1/4"

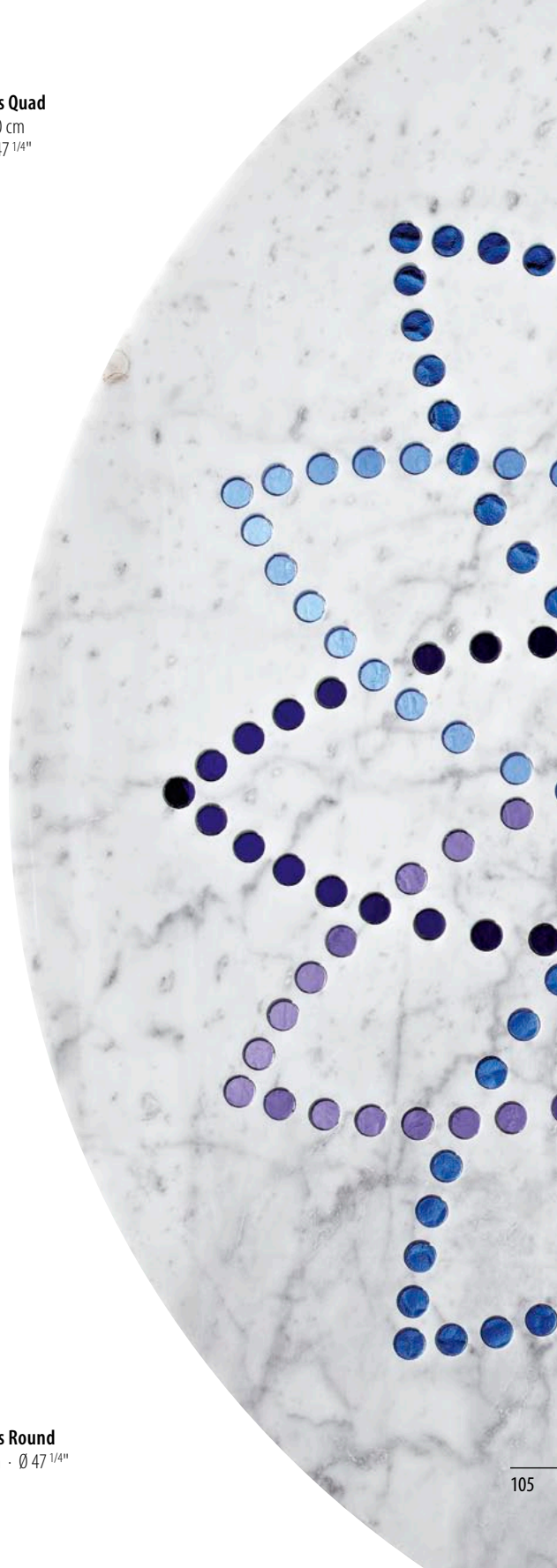

Solangis Round

Ø 120 cm · Ø 47 1/4"

Inxert White



SICIS

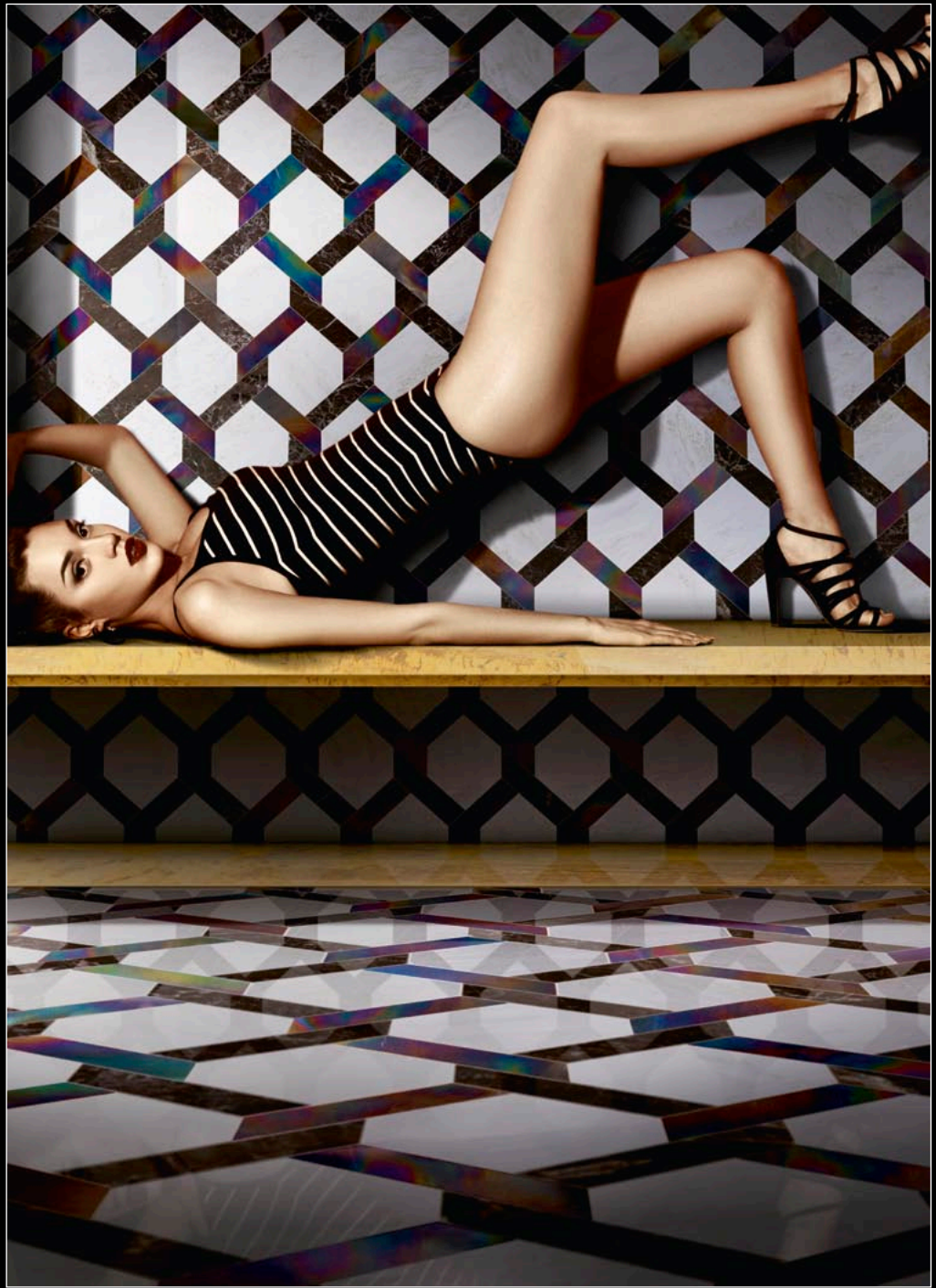



Elecos Kaki

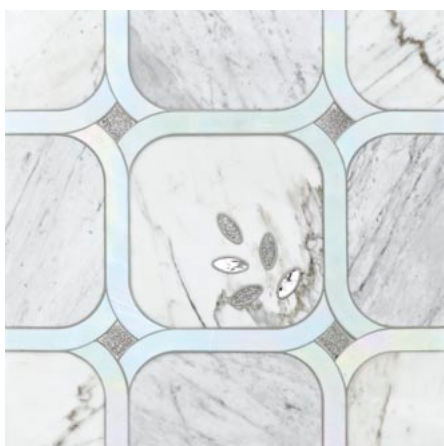

Elecos Irid



Margaritas White



Amapola Grey



Anemil Grey

SICIS

Margaritas White



Amidele WH

with Artistic Mosaic inserts



SICIS



Amidele WH



Iberis White

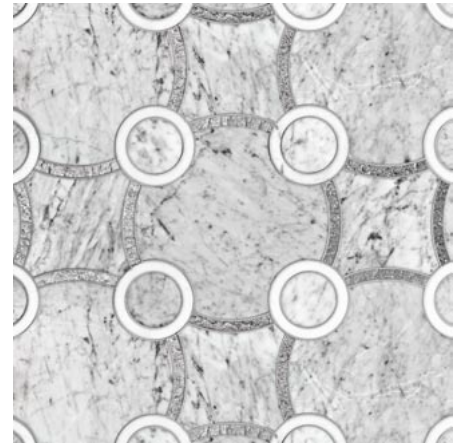

Sirides White



Enlaxo White

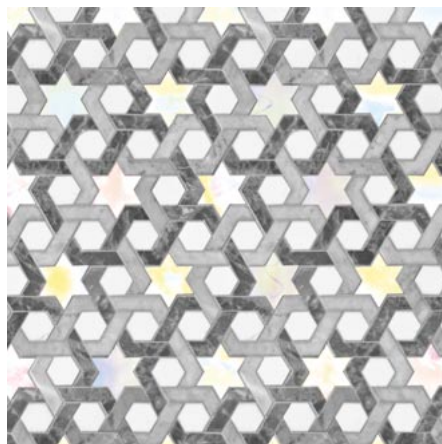

Firmamentus GR



Aloina White

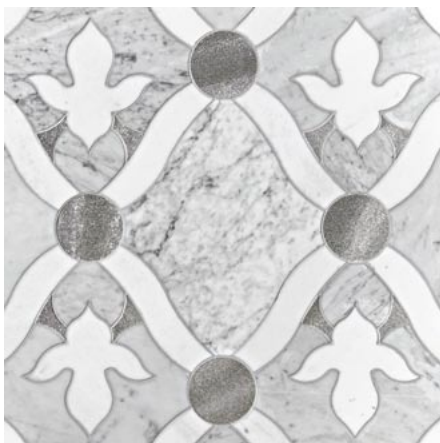

Dralis Flor Grey

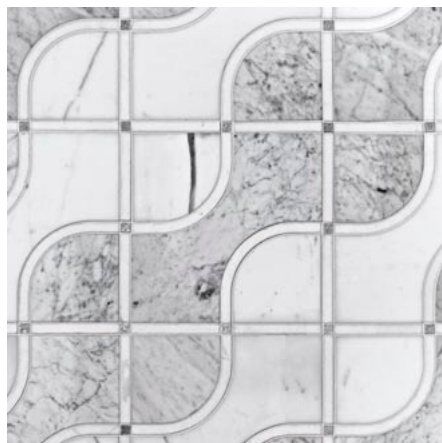

Meandros White

Azahar Irid



Heliantus GR



SICIS



Liasel



SICIS

Marrakech Grey

SICIS

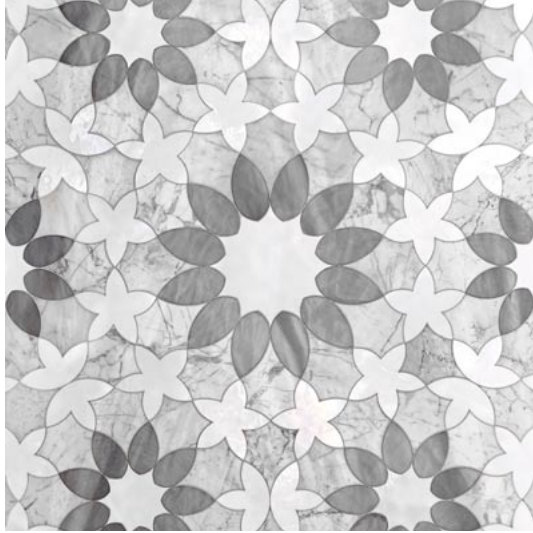

Marrakech Grey

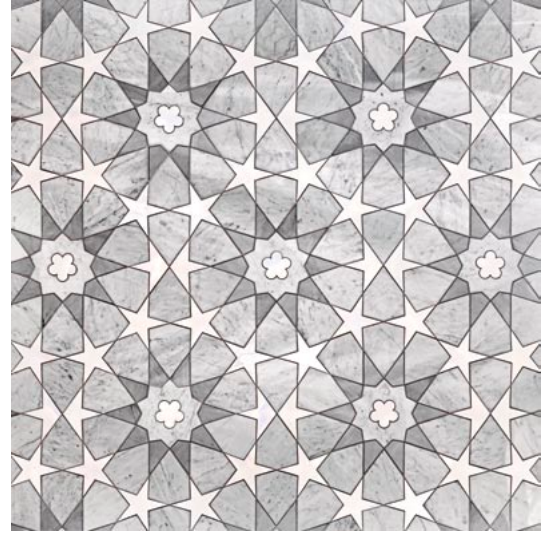

Andalusì Grey

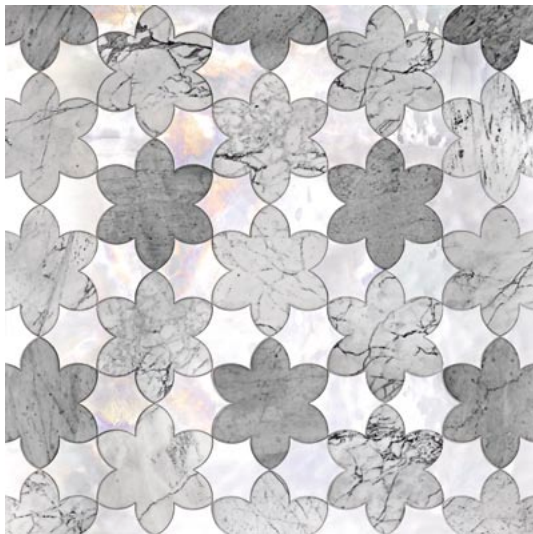

Kasbah Grey

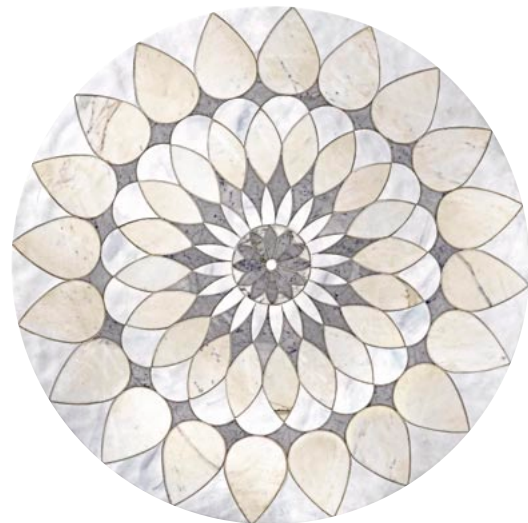

Califa White

Size: Ø 120 cm · Ø 47 1/4"



Aquarium Bianco Namibia



SICIS





Studs

SICIS

Ebrick & Studs

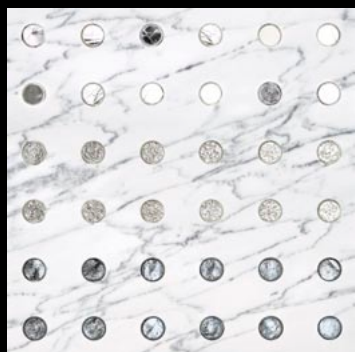

Studs 01 Statuario

30,5 x 30,5 cm · 12" x 12"

with *Colibri: Alma, Vis One, Hermes*



Ebrick 01 Statuario - Nero

30,5 x 30,5 cm · 12" x 12"



Base Statuario

H 10 cm · H 3 7/8"



Studs 02 Statuario - Nero

30,5 x 15 cm · 12" x 5 7/8"

with *Colibri: Alma, Vis One*

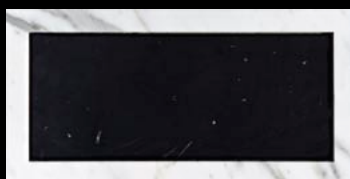

Ebrick 02 Statuario - Nero

30,5 x 15 cm · 12" x 5 7/8"

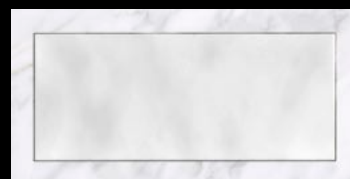

Ebrick 02 Statuario - White Murano

30,5 x 15 cm · 12" x 5 7/8"

with *White Murano*

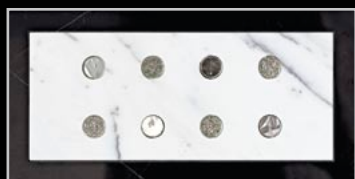

Studs 02 Nero - Statuario

30,5 x 15 cm · 12" x 5 7/8"

with *Colibri: Alma, Vis One*

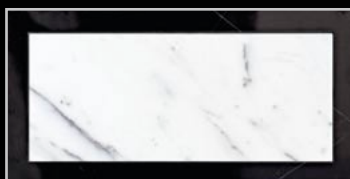

Ebrick 02 Nero - Statuario

30,5 x 15 cm · 12" x 5 7/8"

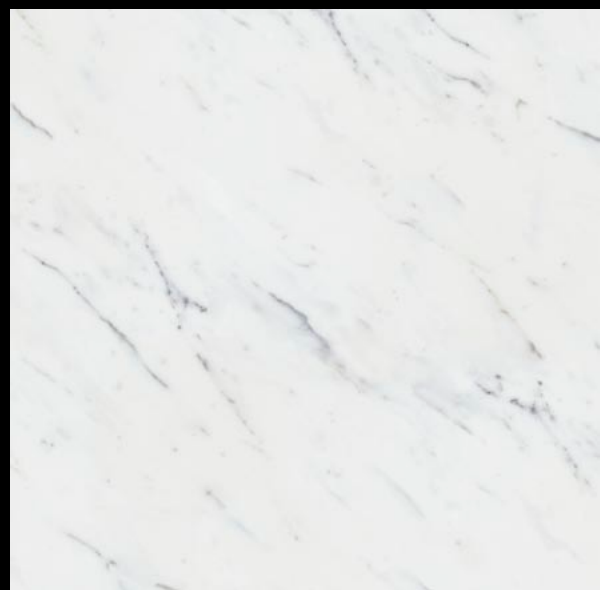



Studs 01 Bardigietto
30,5 x 30,5 cm · 12" x 12"
with Colibrì: Chantal, Tharsis, Caredal



Ebrick 01 Bardigietto - Statuario
30,5 x 30,5 cm · 12" x 12"



Base Bardigietto
H 10 cm · H 3 7/8"

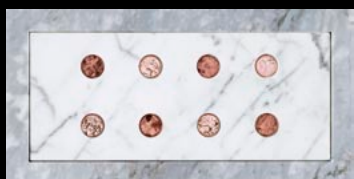

Studs 02 Bardigietto - Statuario
30,5 x 15 cm · 12" x 5 7/8"
with Colibrì: Chantal, Tharsis

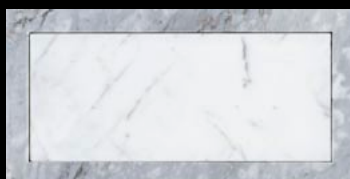

Ebrick 02 Bardigietto - Statuario
30,5 x 15 cm · 12" x 5 7/8"

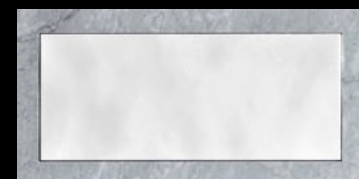

Ebrick 02 Bardigietto - White Murano
30,5 x 15 cm · 12" x 5 7/8"
with White Murano

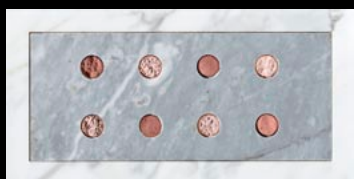

Studs 02 Statuario - Bardigietto
30,5 x 15 cm · 12" x 5 7/8"
with Colibrì: Chantal, Tharsis

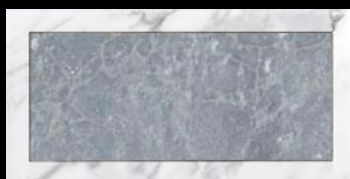

Ebrick 02 Statuario - Bardigietto
30,5 x 15 cm · 12" x 5 7/8"



Complementary Product
Statuario · 30,5 x 61 cm · 12" x 24"

Bardiglio Orientale

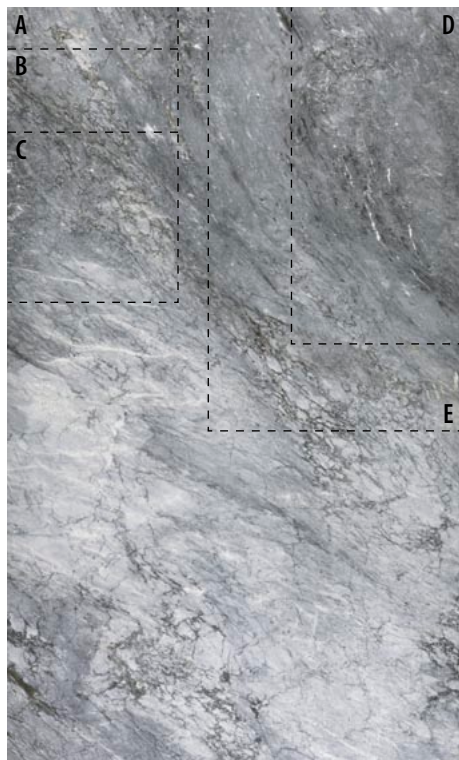

Item A

15 x 60 cm · 5 7/8" x 23 5/8"

Item B

30 x 60 cm · 11 3/4" x 23 5/8"

Item C

60 x 60 cm · 23 5/8" x 23 5/8"

Item D

60 x 120 cm · 23 5/8" x 47 1/4"

Item E

90 x 150 cm · 35 3/8" x 59"

... and more

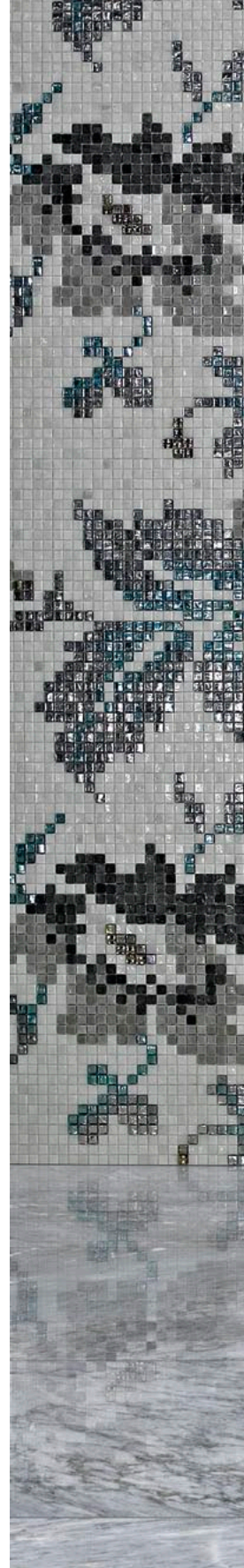



SICIS

Buggy

Bardiglio Imperiale

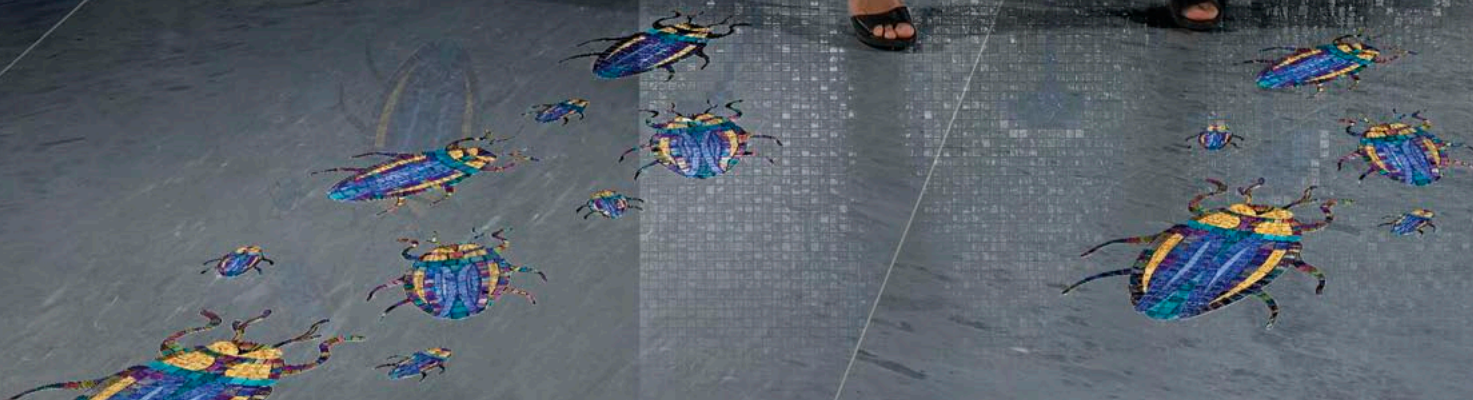
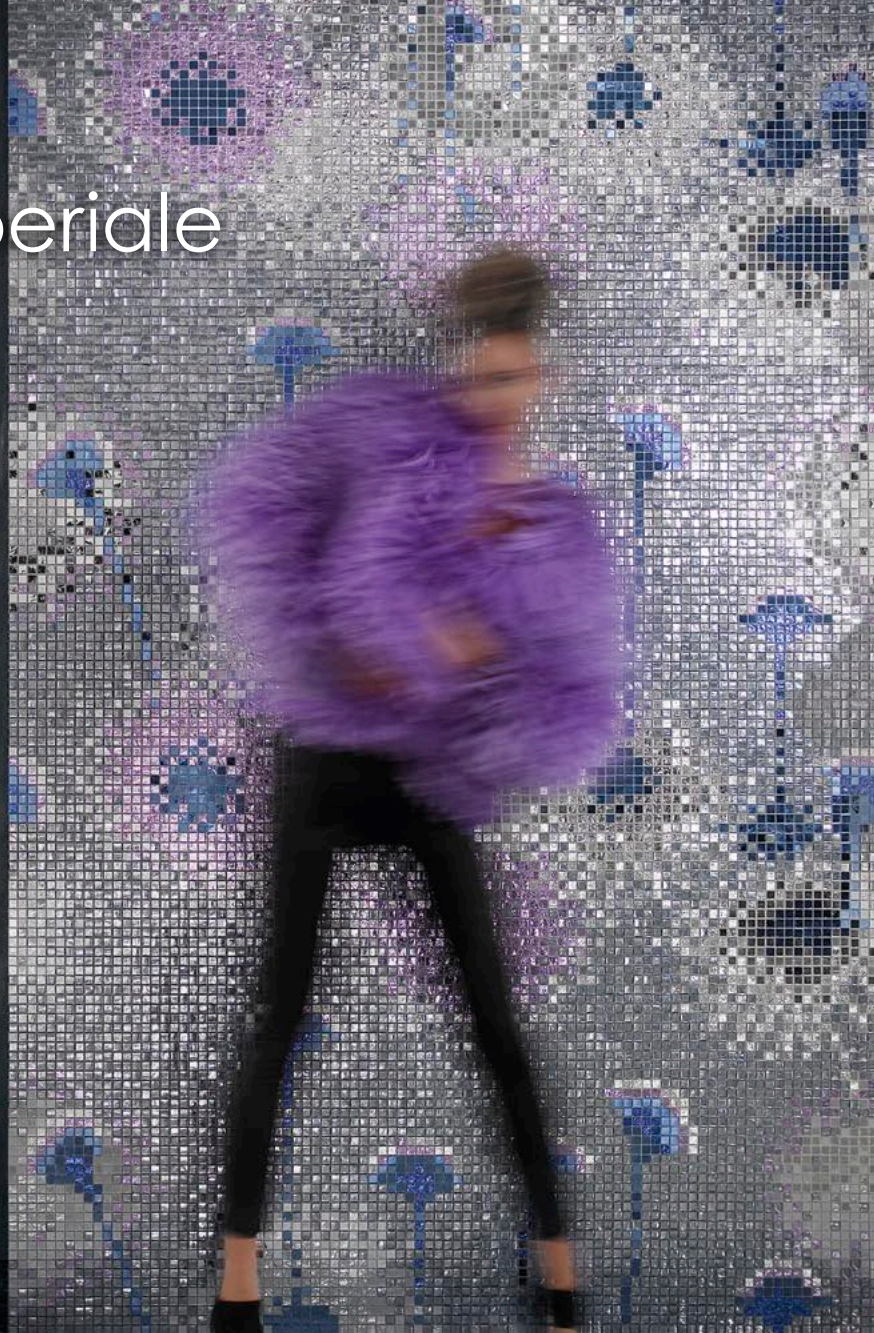

Buggy



Small Bug

6,9 x 7,4 cm
2 ³/₄" x 2 ⁷/₈"

Medium Bug

17,8 x 23,2 cm
7" x 9 ¹/₈"

Large Bug

29,9 x 38,9 cm
11 ³/₄" x 15 ³/₈"

Misure riferite
al solo mosaico.

*Measures are referred
to mosaic only.*

SICIS

Black

SICIS



Baikal Rock



Portoro Extra



Noir Saint Laurent

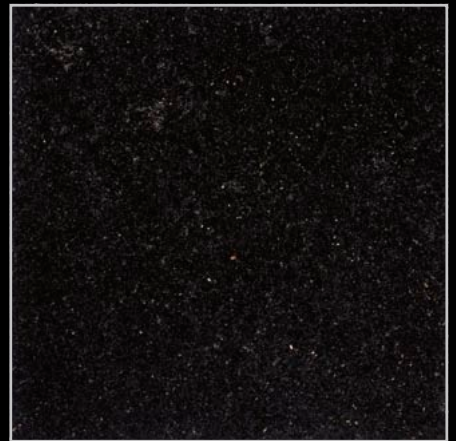

Galaxy Black



Nero



Ebony Black

Heliantus Black & Gold





Scorpions Baikal Rock

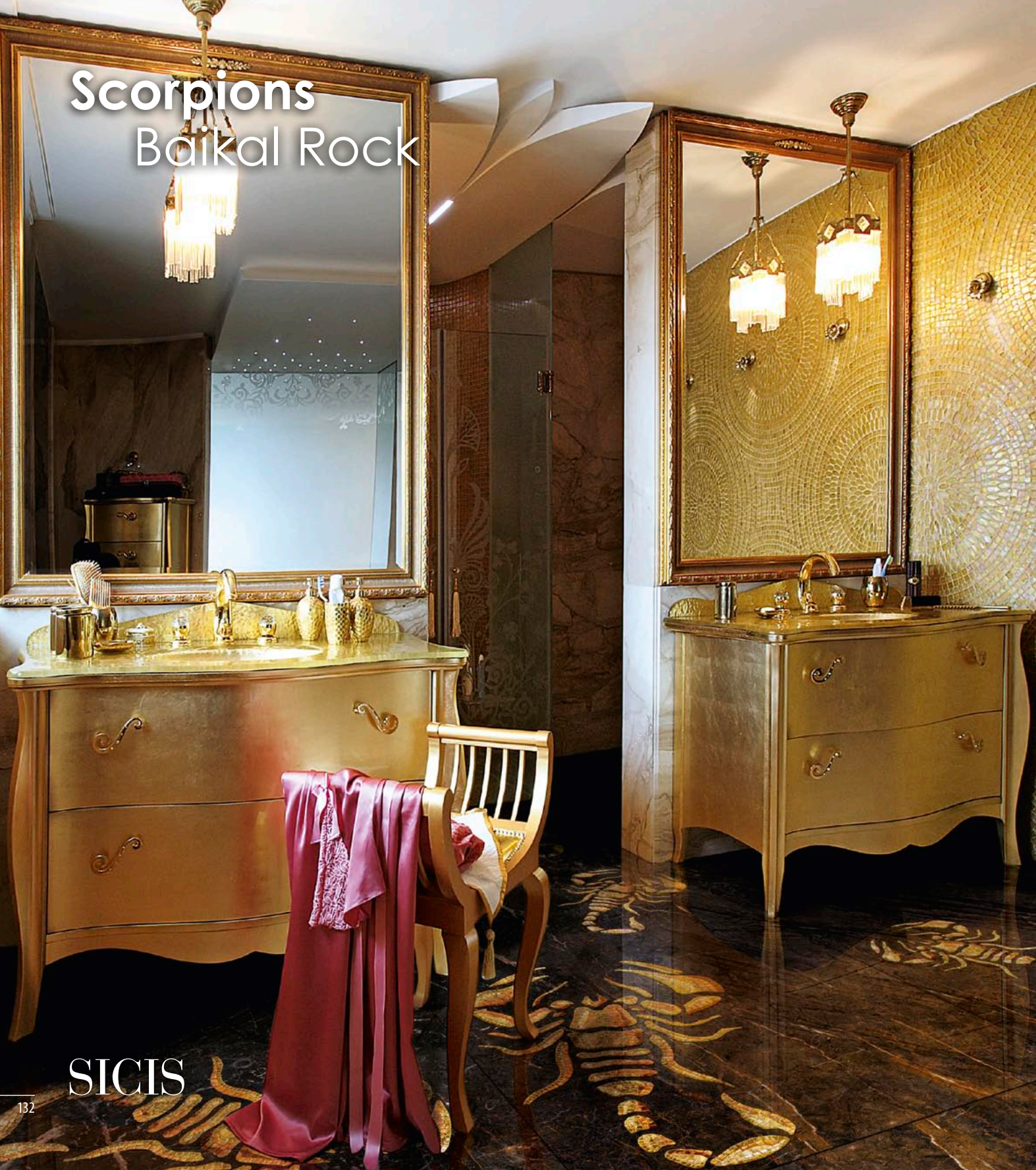

SICIS

Scorpions



Small Scorpion
42,8 x 49,5 · 16^{7/8}" x 19^{1/2}"

Large Scorpion
61,3 x 87,9 · 24^{1/8}" x 34^{5/8}"

Misure riferite al solo mosaico.
Measures are referred to mosaic only.



Alia Brown
Baikal Rock

SICIS



Baikal Rock

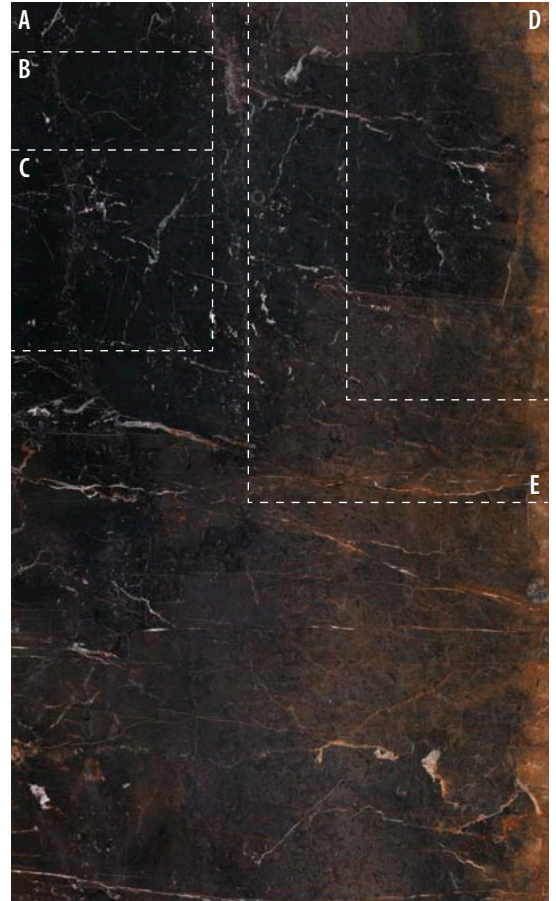

Item A
15 x 60 cm · 5^{7/8}" x 23^{5/8}"

Item B
30 x 60 cm · 11^{3/4}" x 23^{5/8}"

Item C
60 x 60 cm · 23^{5/8}" x 23^{5/8}"

Item D
60 x 120 cm · 23^{5/8}" x 47^{1/4}"

Item E
90 x 150 cm · 35^{3/8}" x 59"

... and more



SICIS

Alia Black

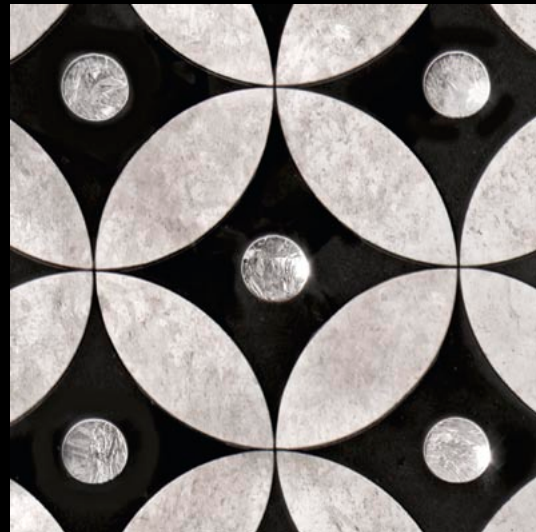

Alia Black

Portoro Extra

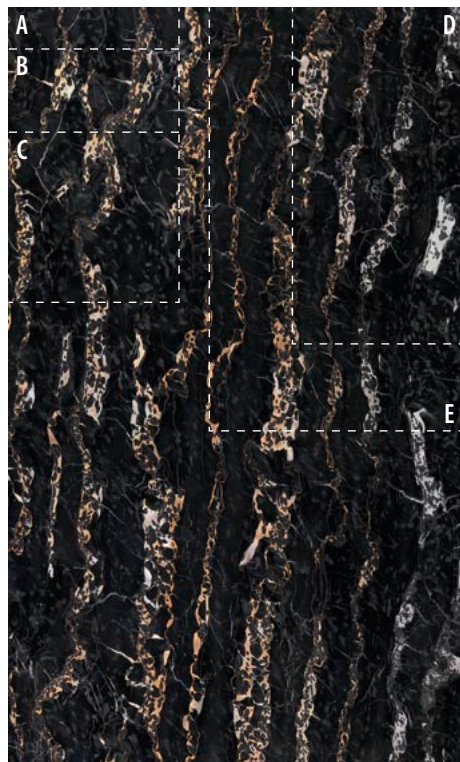

*Thickness:
minimum 2 cm · 3/4"*

Item A
15 x 60 cm · 5 7/8" x 23 5/8"

Item B
30 x 60 cm · 11 3/4" x 23 5/8"

Item C
60 x 60 cm · 23 5/8" x 23 5/8"

Item D
60 x 120 cm · 23 5/8" x 47 1/4"

Item E
90 x 150 cm · 35 3/8" x 59"

... and more





SICIS



SICIS

Magreb Black

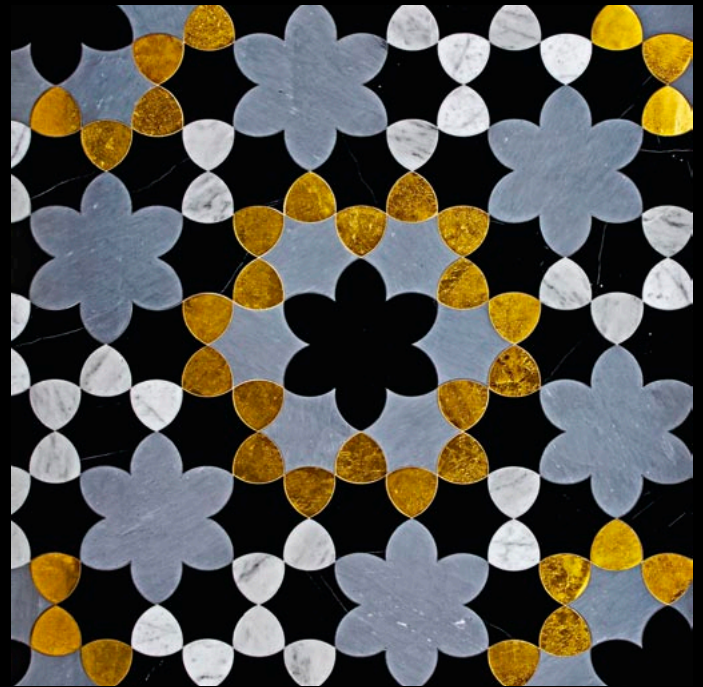

Magreb Black



Amidele BLC

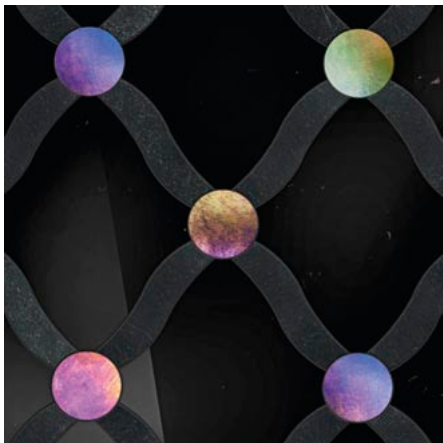

Dralis Black

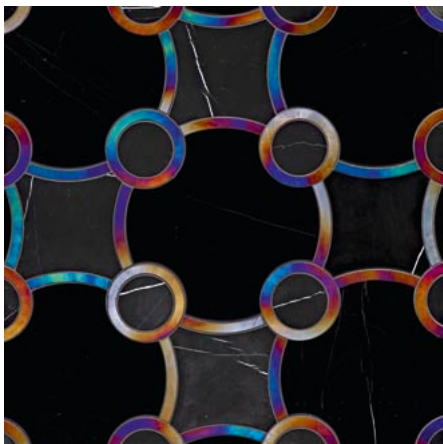

Sirides Black

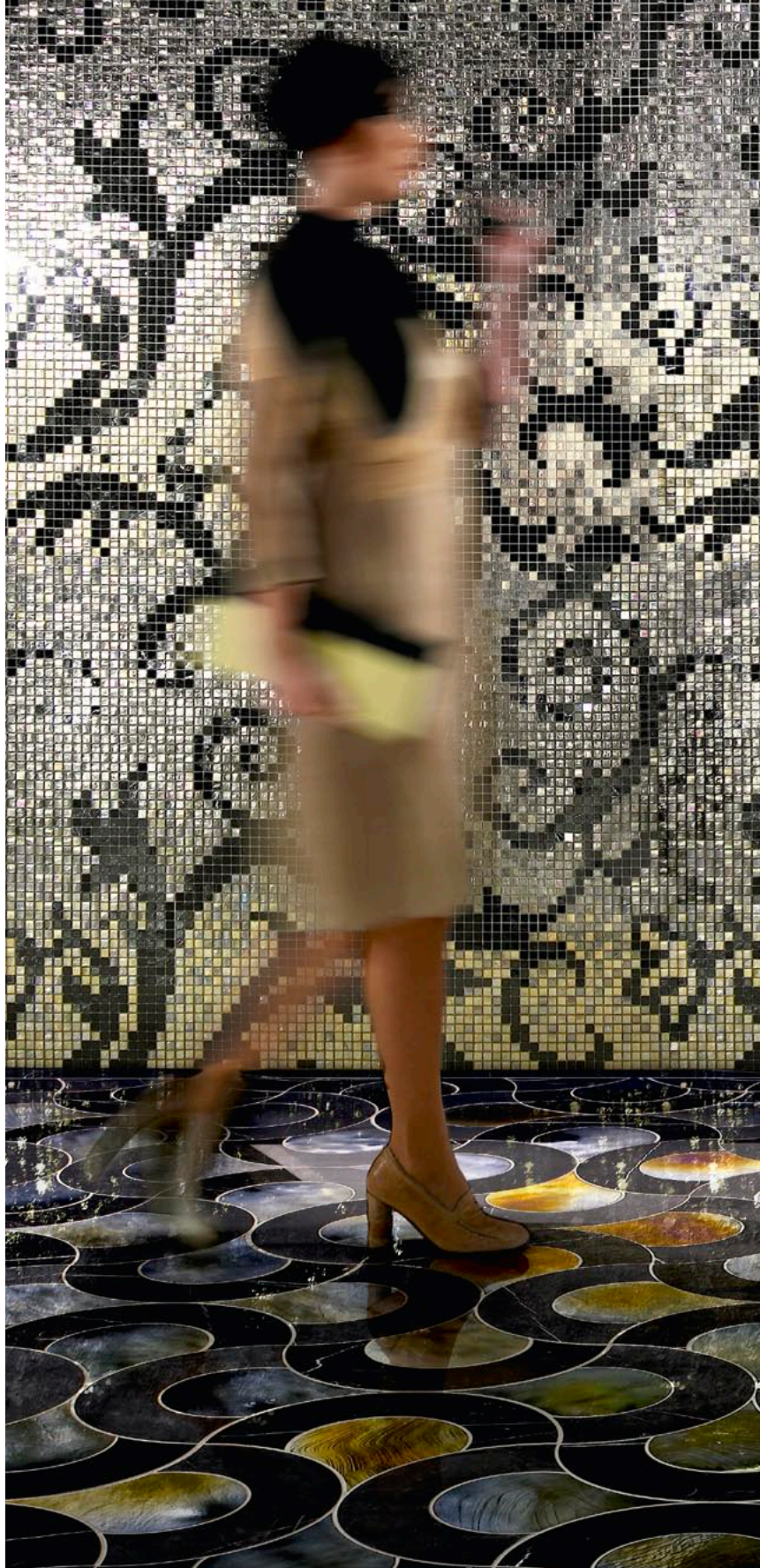



Amidele BLC

SICIS

Algar Grey

SICIS



Algar Grey



Meandros Black

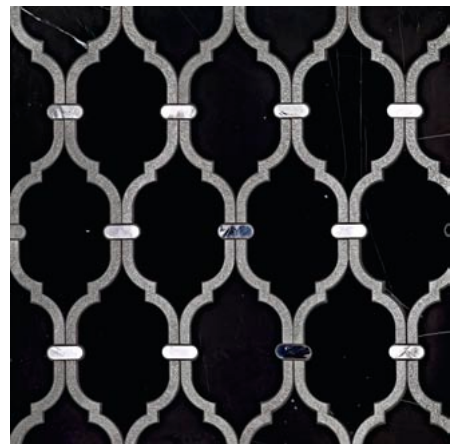

Aloina Black

Ebony Black

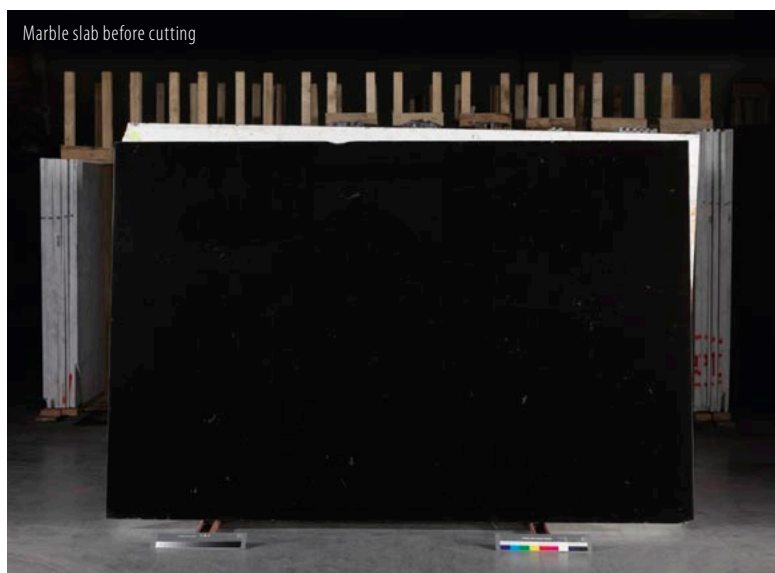

Item A

15 x 60 cm · 5⁷/₈" x 23⁵/₈"

Item B

30 x 60 cm · 11³/₄" x 23⁵/₈"

Item C

60 x 60 cm · 23⁵/₈" x 23⁵/₈"

Item D

60 x 120 cm · 23⁵/₈" x 47¹/₄"

Item E

90 x 150 cm · 35³/₈" x 59"

... and more

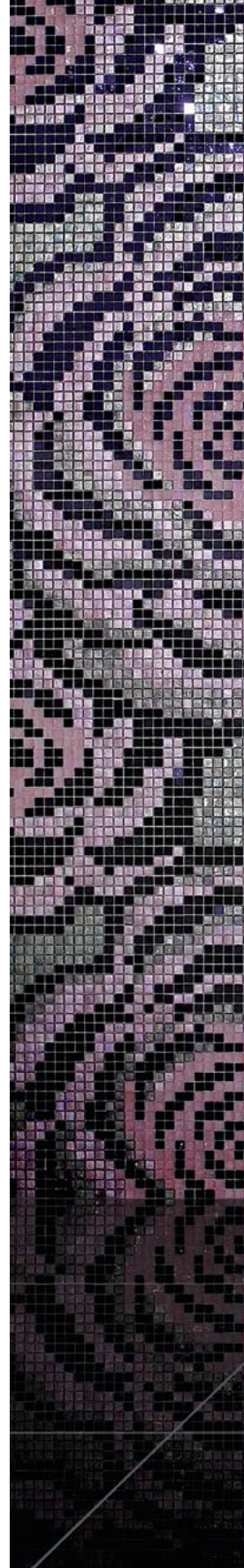



SICIS

Abanicos

Ebony Black



SICIS



Abanicos

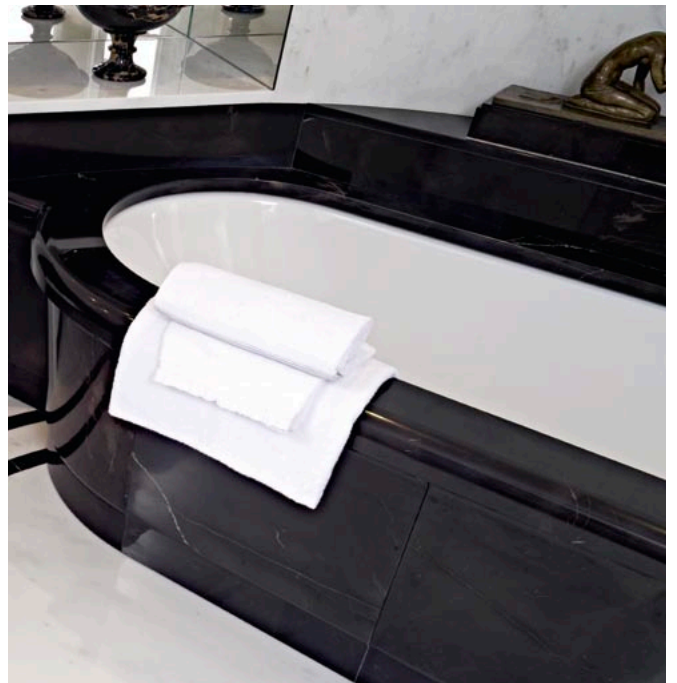

SICIS



Clessidra Small Black

SICIS

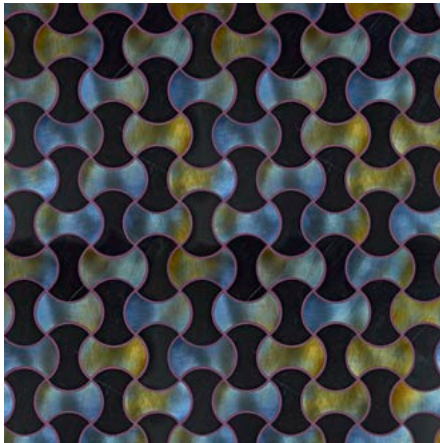

Clessidra Small Black

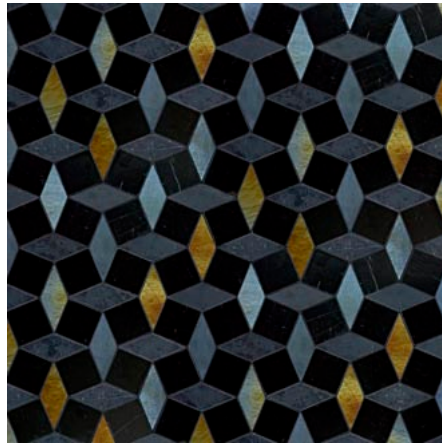

Jalisco Small Black

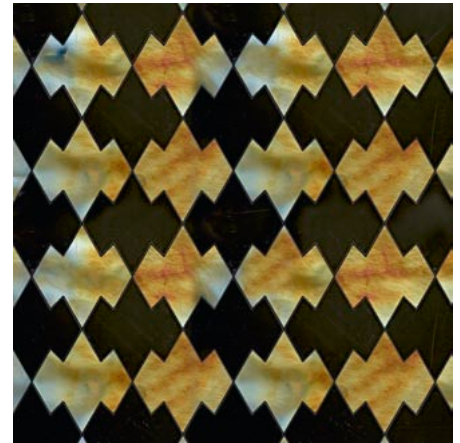

Azetek Small Black

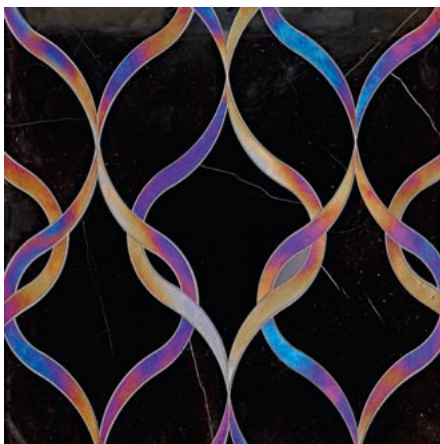

Serpentine Black

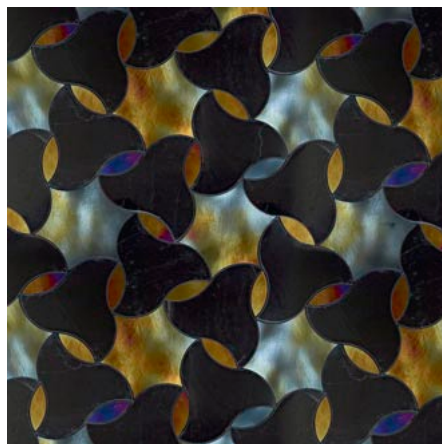

Sidonel Small Black

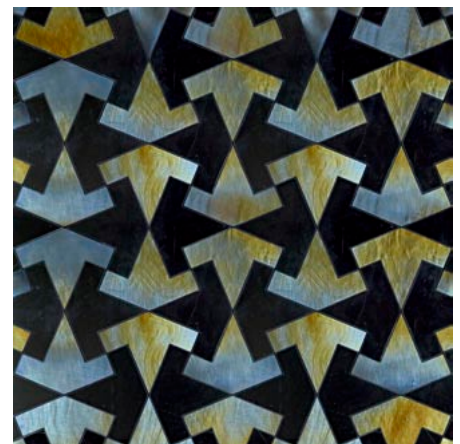

Tintay Small Black



Toral Small Black

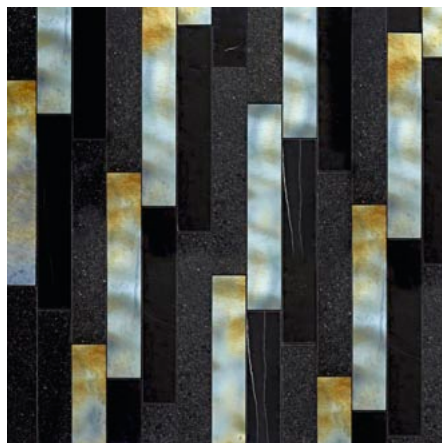

Zambra





Caleidos

SICIS

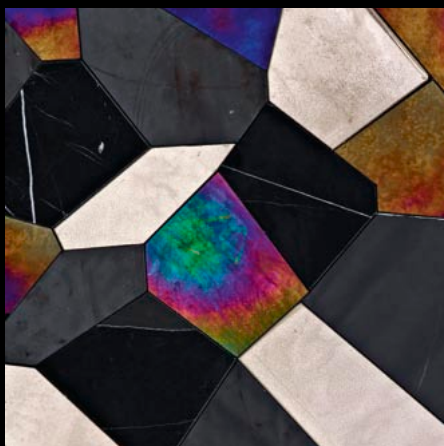

Caleidos Platinum

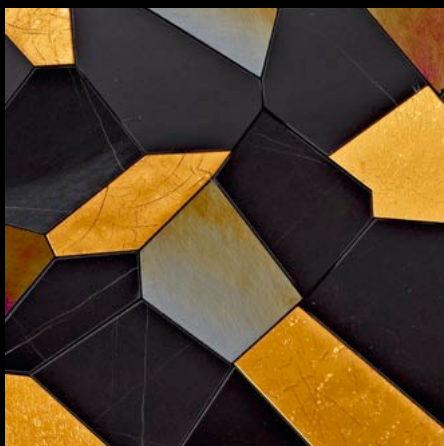

Caleidos Gold



Caleidos



Caleidos Grey



Caleidos Brown



Caleidos Caramel

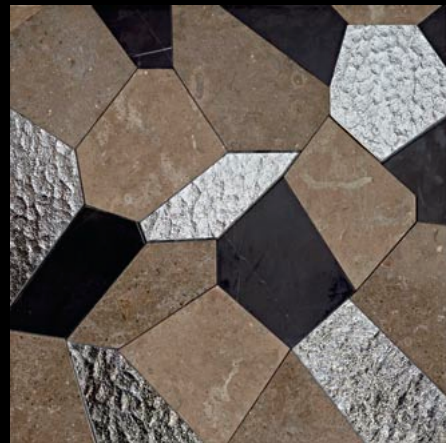

Caleidos Tobacco

Caleidos



SICIS



Firmamentus BLC



SICIS



Marrakech Black

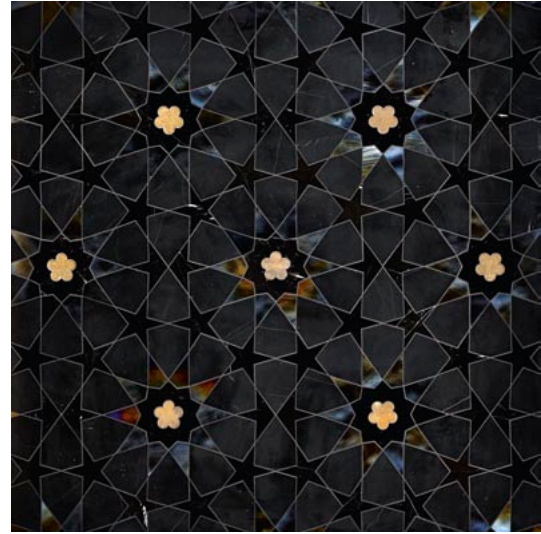

Andalusì Black

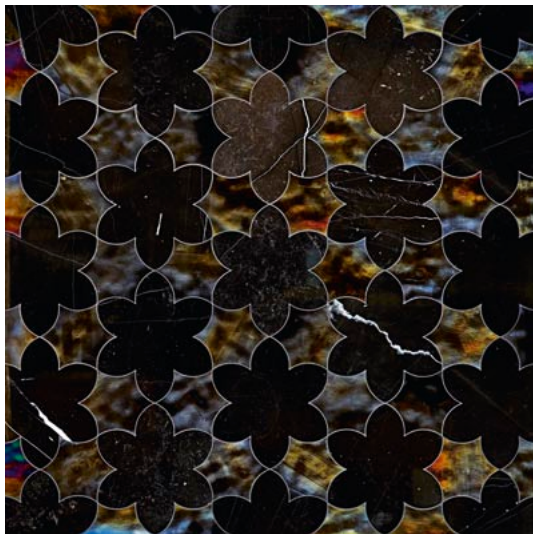

Kasbah Black



Califa Black

Size: Ø 120 cm · Ø 47 1/4"

Aquarium Yellow

Noir Saint Laurent



SICIS

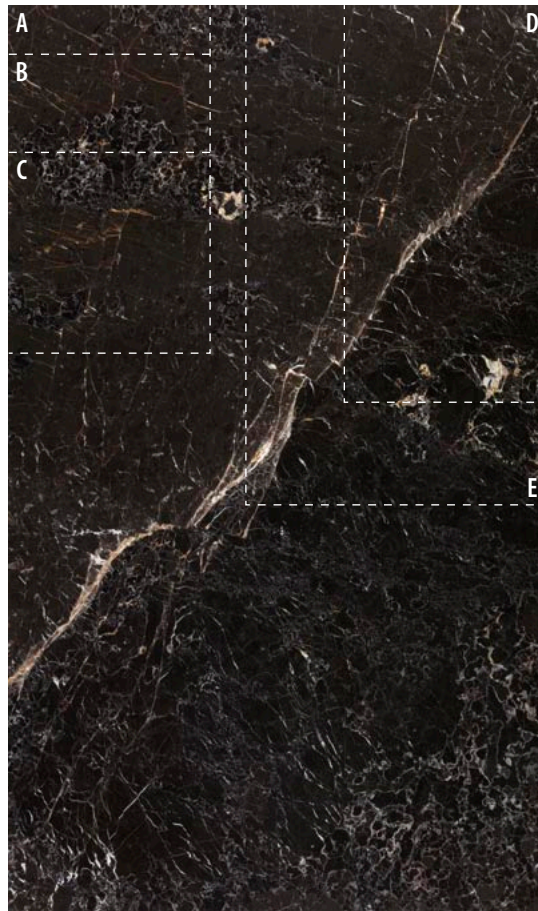
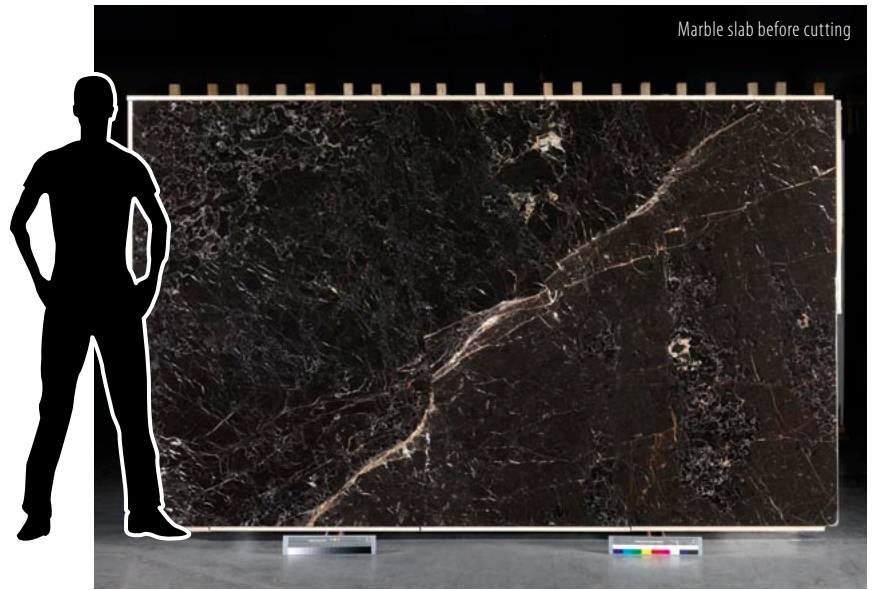
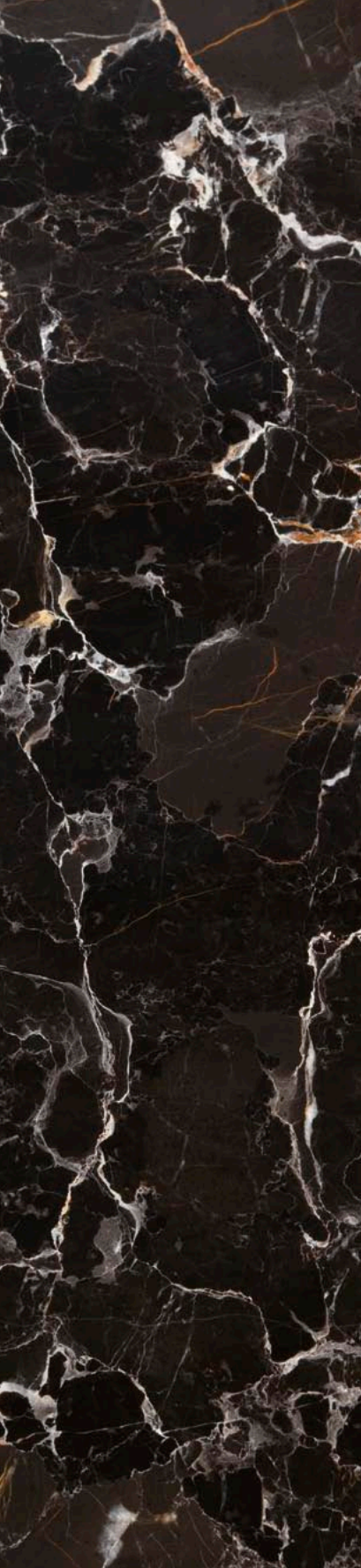

Item A
15 x 60 cm · 5 7/8" x 23 5/8"

Item B
30 x 60 cm · 11 3/4" x 23 5/8"

Item C
60 x 60 cm · 23 5/8" x 23 5/8"

Item D
60 x 120 cm · 23 5/8" x 47 1/4"

Item E
90 x 150 cm · 35 3/8" x 59"

... and more



SICIS

Nocturnia BL

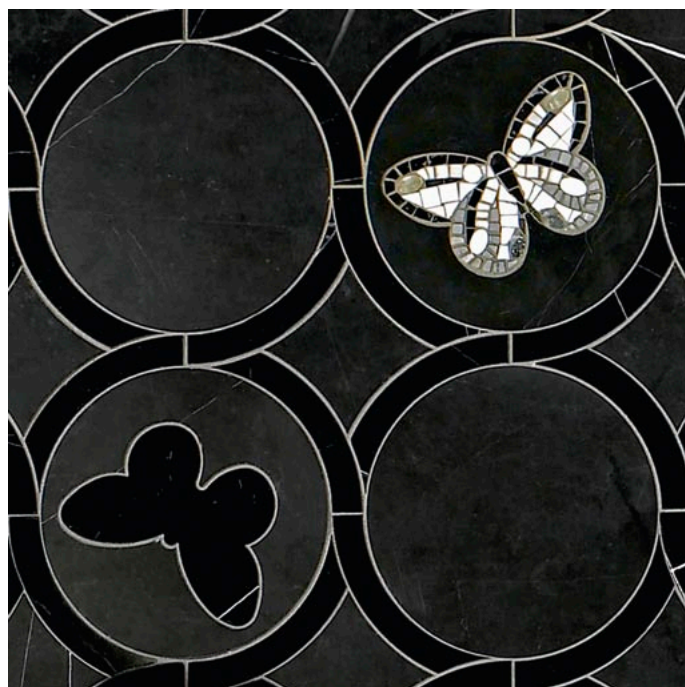

Nocturnia BL



Beige

SICIS

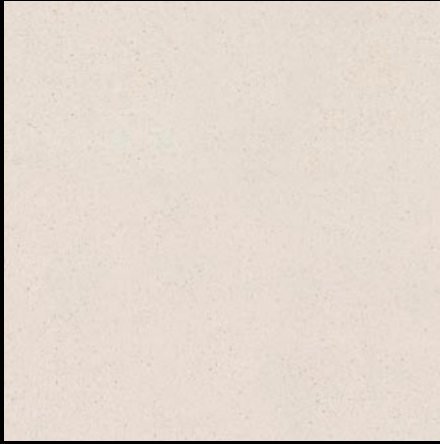

Anastasia



Bianco Perlato



Onice Bianco



Bianco Antico



Botticino



Travertino



Onice Spider White



Zebrino



Crema

Gilius Beige







SICIS

Olson Cappuccino



Olson Cappuccino



Cadeira Crema

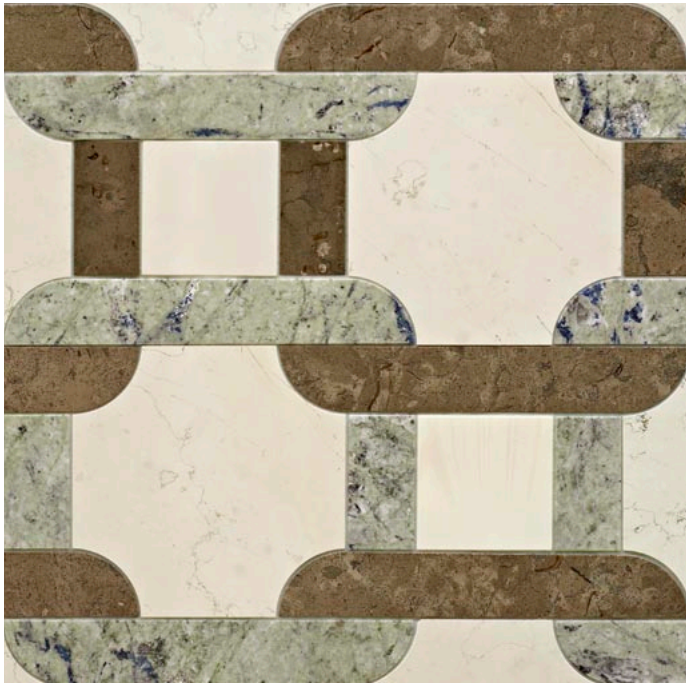

Cadeira Crema





Bianco Perlato





SICIS



Ferias BE
Bianco Perlato

SICIS

Bianco Perlato

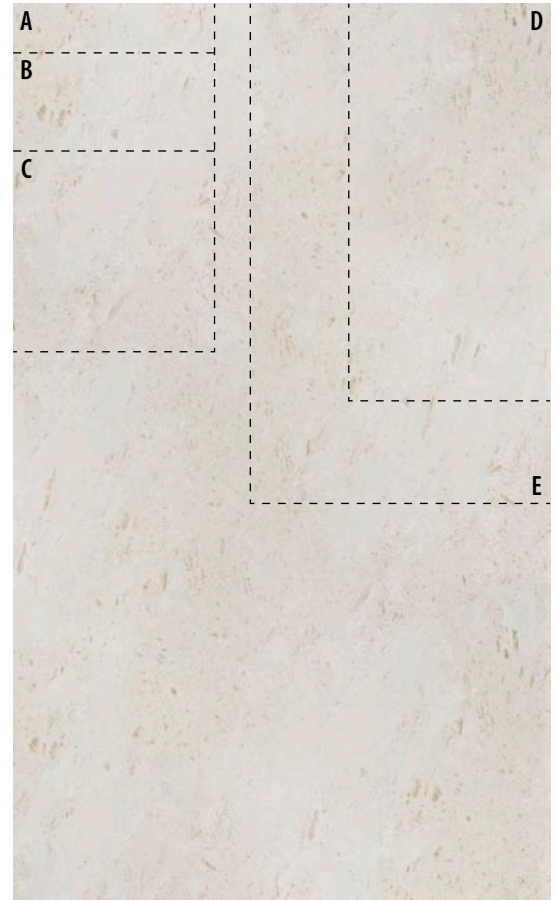

Item A
15 x 60 cm · 5^{7/8}" x 23^{5/8}"

Item B
30 x 60 cm · 11^{3/4}" x 23^{5/8}"

Item C
60 x 60 cm · 23^{5/8}" x 23^{5/8}"

Item D
60 x 120 cm · 23^{5/8}" x 47^{1/4}"

Item E
90 x 150 cm · 35^{3/8}" x 59"

... and more



SICIS

Primavera Combination
(9 pieces 45,7 x 45,7 cm · 18" x 18")
135 x 135 cm · 53 1/8" x 53 1/8"

Primavera Anastasia





Amidele BE
Onice Bianco

SICIS

Onice Bianco



Item A
15 x 60 cm · 5^{7/8}" x 23^{5/8}"

Item B
30 x 60 cm · 11^{3/4}" x 23^{5/8}"

Item C
60 x 60 cm · 23^{5/8}" x 23^{5/8}"

Item D
60 x 120 cm · 23^{5/8}" x 47^{1/4}"

Item E
90 x 150 cm · 35^{3/8}" x 59"

... and more



Azahar Beige
Onice Spider White

SICIS

Onice Spider White

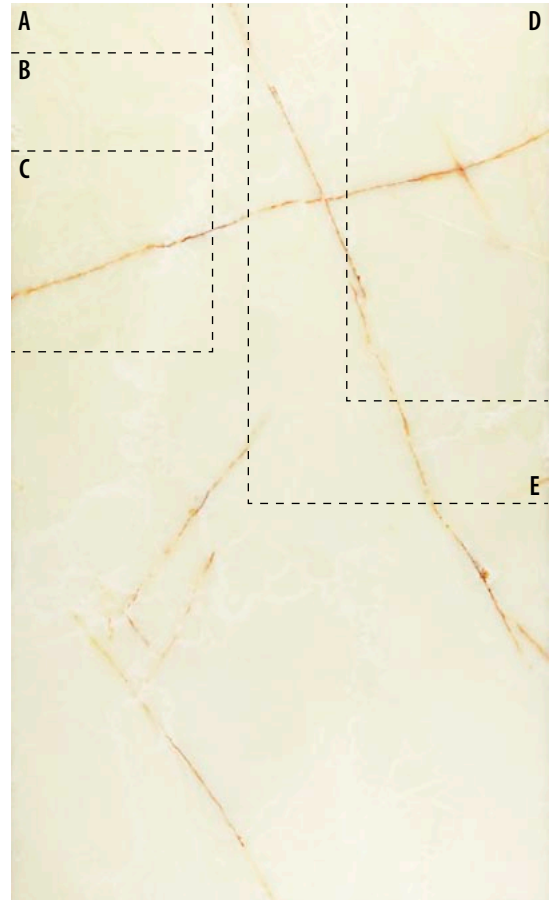

Item A
15 x 60 cm · 5^{7/8}" x 23^{5/8}"

Item B
30 x 60 cm · 11^{3/4}" x 23^{5/8}"

Item C
60 x 60 cm · 23^{5/8}" x 23^{5/8}"

Item D
60 x 120 cm · 23^{5/8}" x 47^{1/4}"

Item E
90 x 150 cm · 35^{3/8}" x 59"

... and more





SICIS

Meandros Grey

Zebrino

SICIS

Zebrino

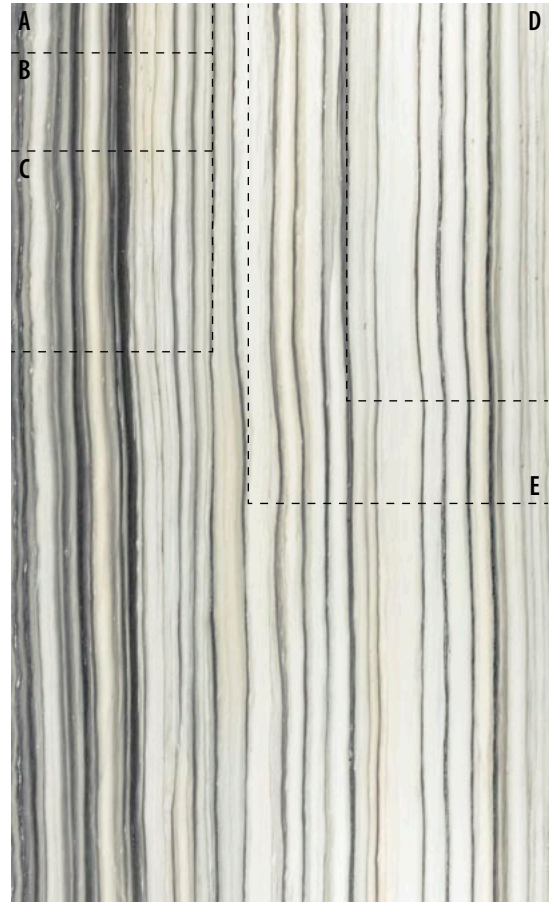
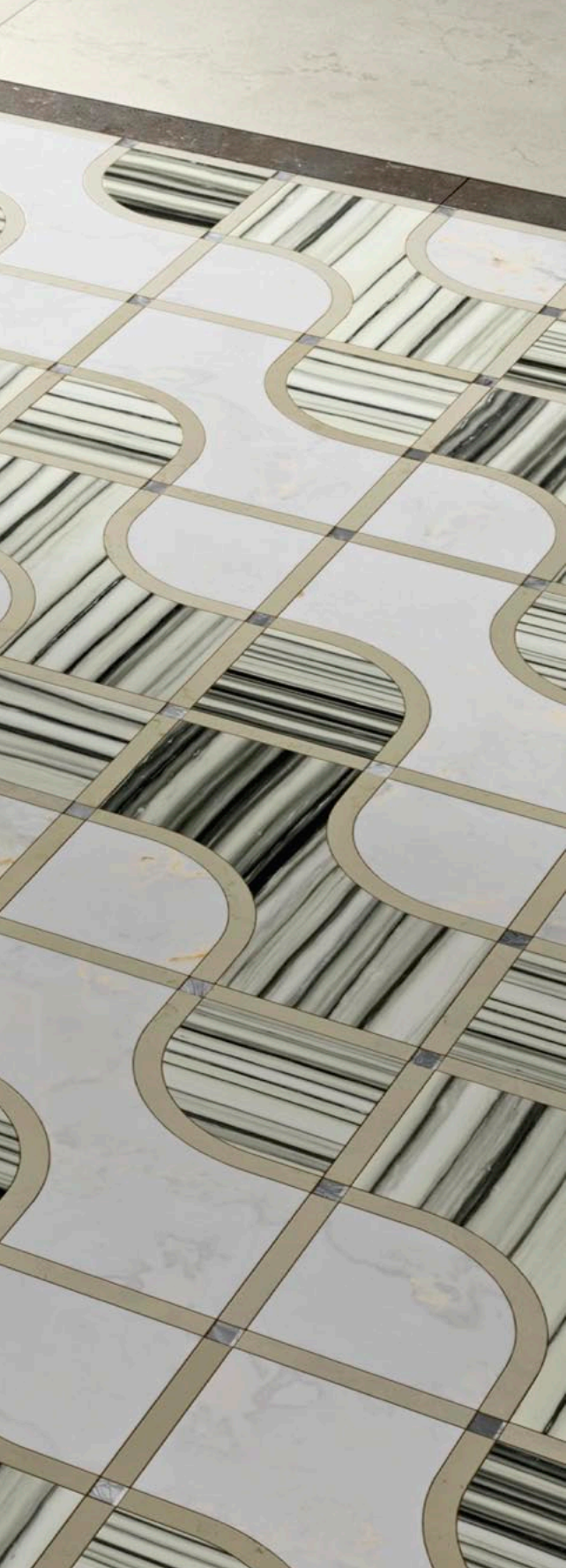

Item A
15 x 60 cm · 5^{7/8}" x 23^{5/8}"

Item B
30 x 60 cm · 11^{3/4}" x 23^{5/8}"

Item C
60 x 60 cm · 23^{5/8}" x 23^{5/8}"

Item D
60 x 120 cm · 23^{5/8}" x 47^{1/4}"

Item E
90 x 150 cm · 35^{3/8}" x 59"

... and more

Golden



Golden Spider



Ambra Gold



Gold Byzantine



Dore Royal



Onice Crema



Onice Miele



Onice Golden

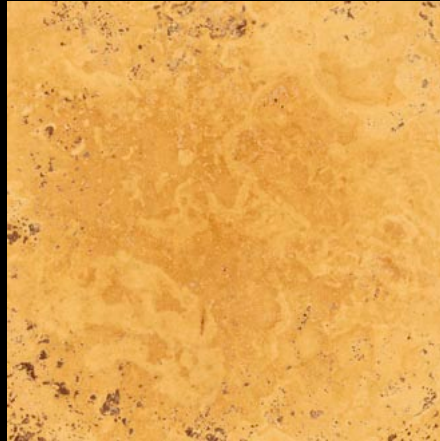

Gold Travertine



Jaune du Roi



Giallo Royal



Yellow Sunset

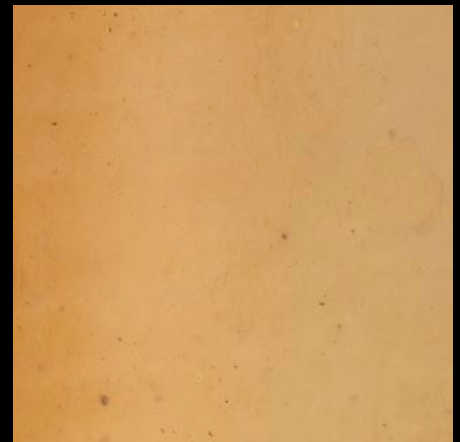

Quarzite Gialla



Alabastro Egiziano



Travertino Giallo



Briar Wood

Onice Crema

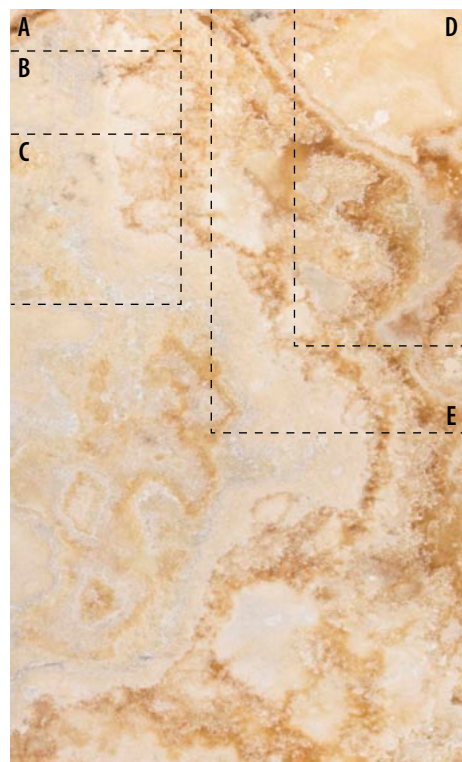
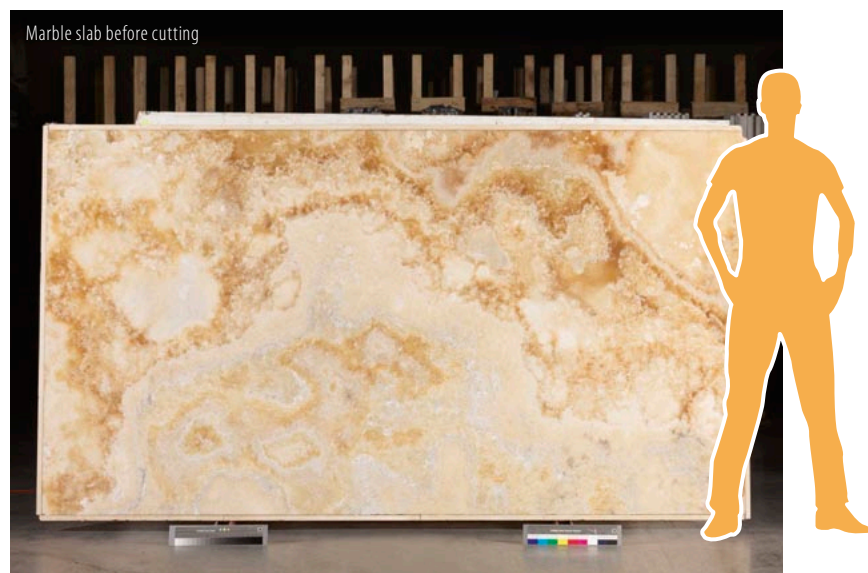

Item A

15 x 60 cm · 5 7/8" x 23 5/8"

Item B

30 x 60 cm · 11 3/4" x 23 5/8"

Item C

60 x 60 cm · 23 5/8" x 23 5/8"

Item D

60 x 120 cm · 23 5/8" x 47 1/4"

Item E

90 x 150 cm · 35 3/8" x 59"

... and more





SICIS

Caleidos Onix

SICIS





Caleidos Onix



Caleidos Beige



Anzis Marble Beige

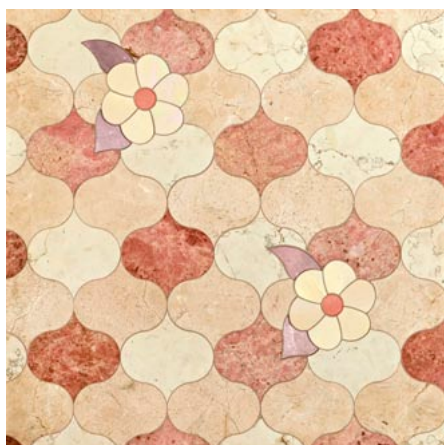

Aguamiel Beige



Petalis Crema



Clessidra Crema

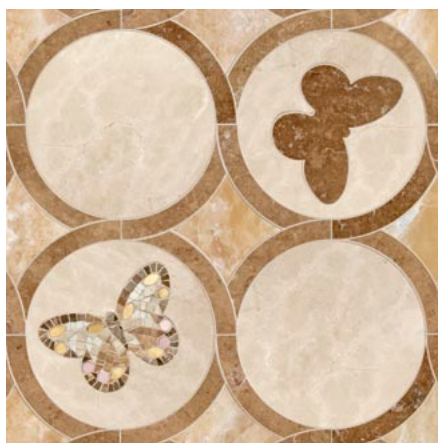

Nocturnia BE

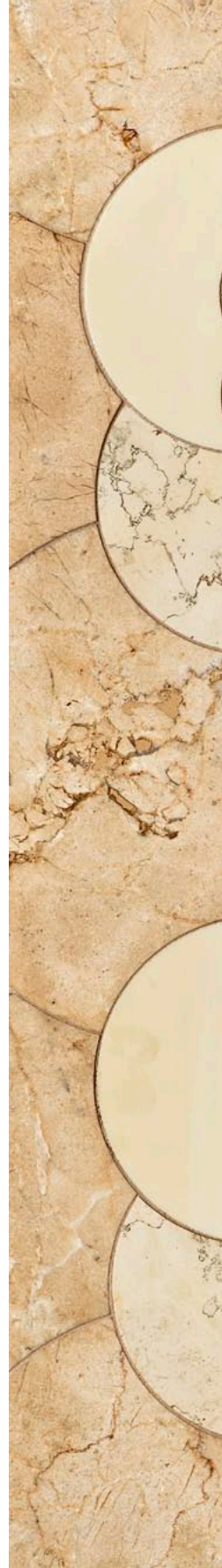

Petalis Crema

SICIS



SICIS

Onice Miele

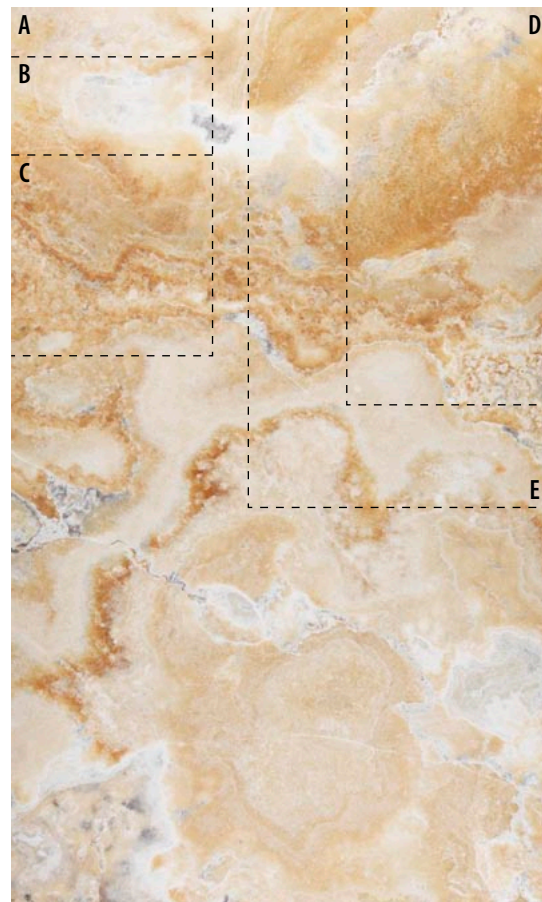

Item A
15 x 60 cm · 5^{7/8}" x 23^{5/8}"

Item B
30 x 60 cm · 11^{3/4}" x 23^{5/8}"

Item C
60 x 60 cm · 23^{5/8}" x 23^{5/8}"

Item D
60 x 120 cm · 23^{5/8}" x 47^{1/4}"

Item E
90 x 150 cm · 35^{3/8}" x 59"

... and more

Andalusì Ocra

The image displays a complex mosaic pattern. The primary elements are golden-yellow pentagonal tiles, each featuring a distinct wood grain texture. These tiles are arranged in a repeating geometric pattern, with their points interlocking to form a series of dark brown, eight-pointed star shapes. At the center of each star is a dark brown, four-petaled floral cutout. The overall effect is a rich, textured surface with a warm, earthy color palette.

SICIS



Andalusì Ocra



Azetek Ocra



Gironda Golden Onice Golden

SICIS

Onice Golden

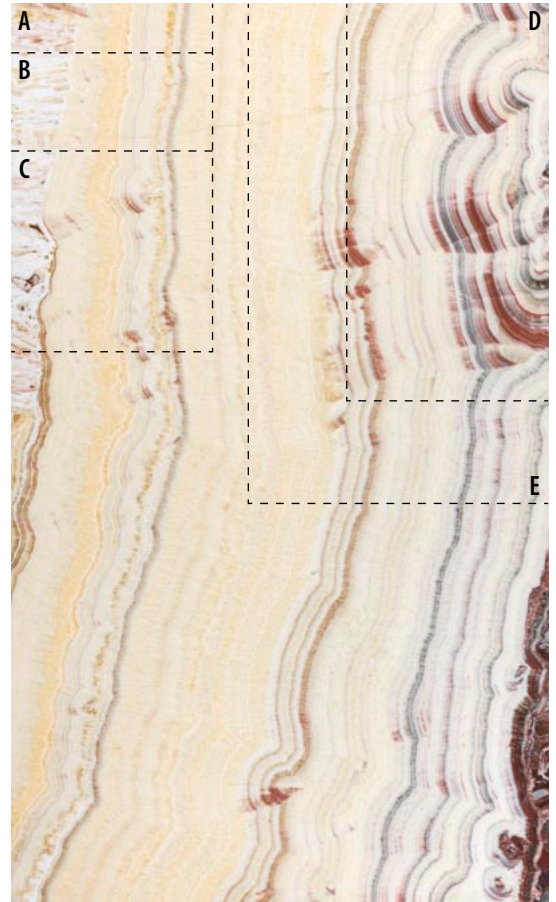

Item A
15 x 60 cm · 5^{7/8}" x 23^{5/8}"

Item B
30 x 60 cm · 11^{3/4}" x 23^{5/8}"

Item C
60 x 60 cm · 23^{5/8}" x 23^{5/8}"

Item D
60 x 120 cm · 23^{5/8}" x 47^{1/4}"

Item E
90 x 150 cm · 35^{3/8}" x 59"

... and more

Quarzite Gialla

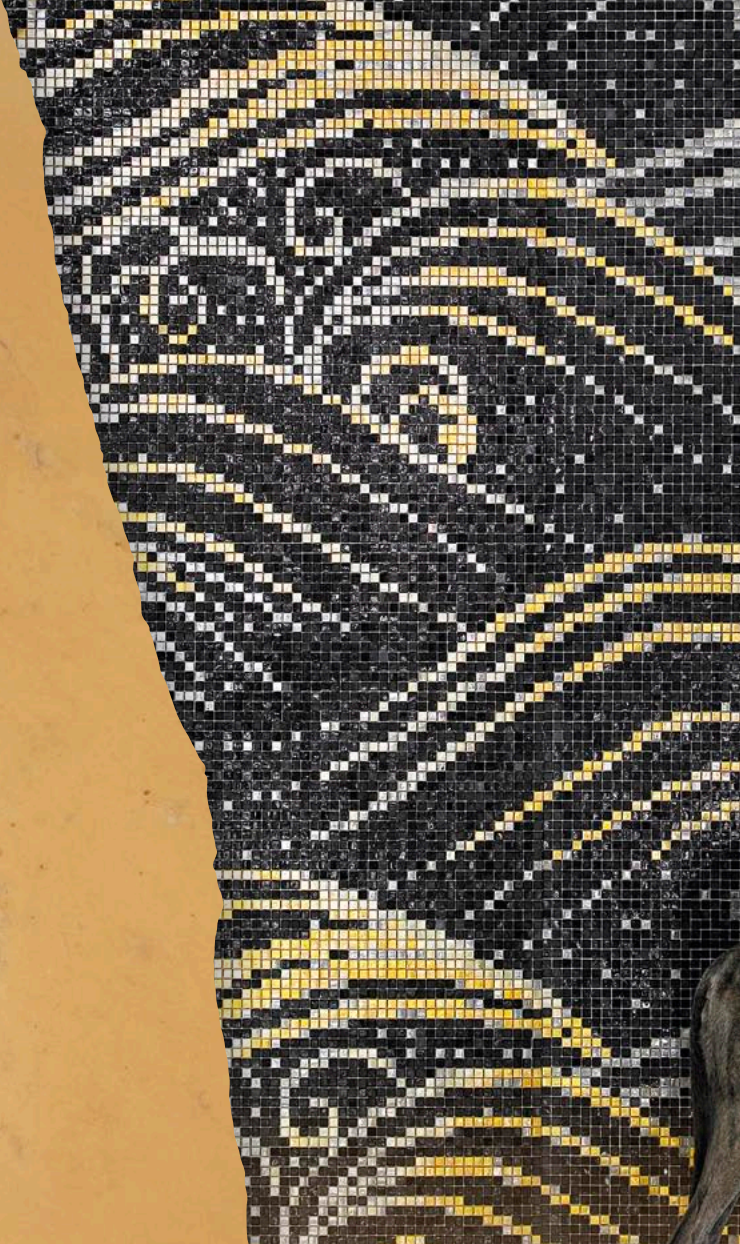

SICIS



The image features a repeating pattern of interlocking, wavy, light grey bands on a warm, golden-yellow background. The bands are outlined in a thin, dark brown line, creating a complex, woven appearance. The overall effect is reminiscent of a decorative tile or a high-quality wallpaper. The pattern is consistent across the entire frame, with a slight perspective shift on the right side.

Serpentine Yellow

Quarzite Gialla

SICIS

Quarzite Gialla

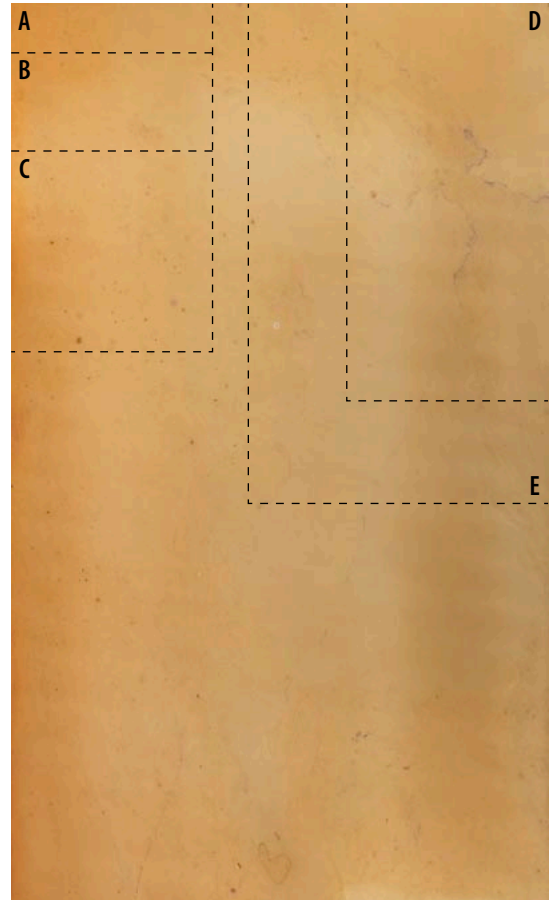

Item A
15 x 60 cm · 5^{7/8}" x 23^{5/8}"

Item B
30 x 60 cm · 11^{3/4}" x 23^{5/8}"

Item C
60 x 60 cm · 23^{5/8}" x 23^{5/8}"

Item D
60 x 120 cm · 23^{5/8}" x 47^{1/4}"

Item E
90 x 150 cm · 35^{3/8}" x 59"

... and more



SICIS



Delicatissimum BEC1



SICIS



Delicatissimum BEC1



Delicatissimum BEC3



Firmamentus BEC

Travertino Giallo

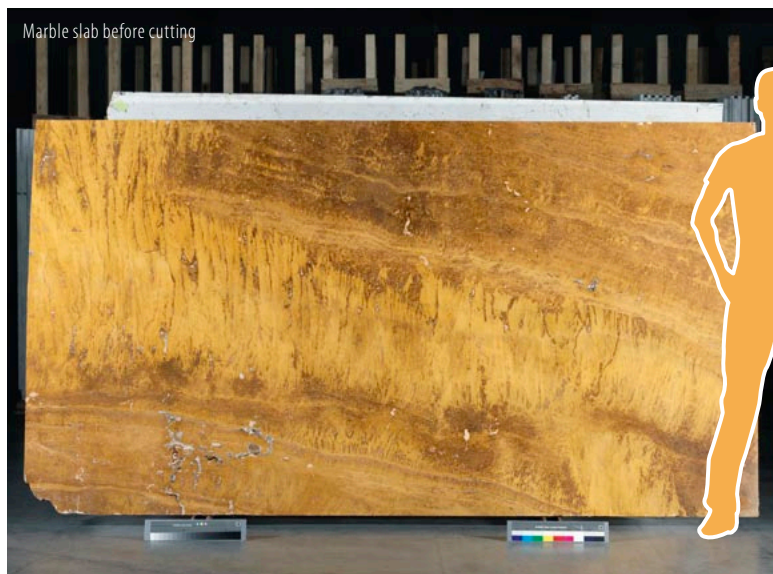

Item A

15 x 60 cm · 5 7/8" x 23 5/8"

Item B

30 x 60 cm · 11 3/4" x 23 5/8"

Item C

60 x 60 cm · 23 5/8" x 23 5/8"

Item D

60 x 120 cm · 23 5/8" x 47 1/4"

Item E

90 x 150 cm · 35 3/8" x 59"

... and more

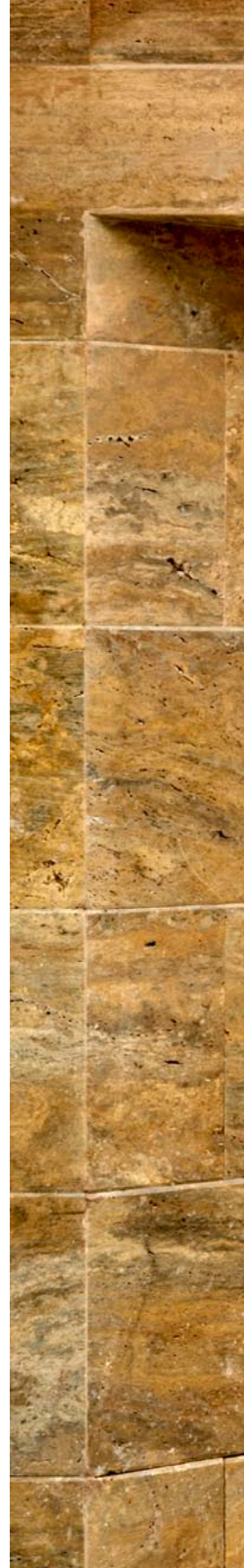



Scorpions Brown

Briar Wood



Briar Wood

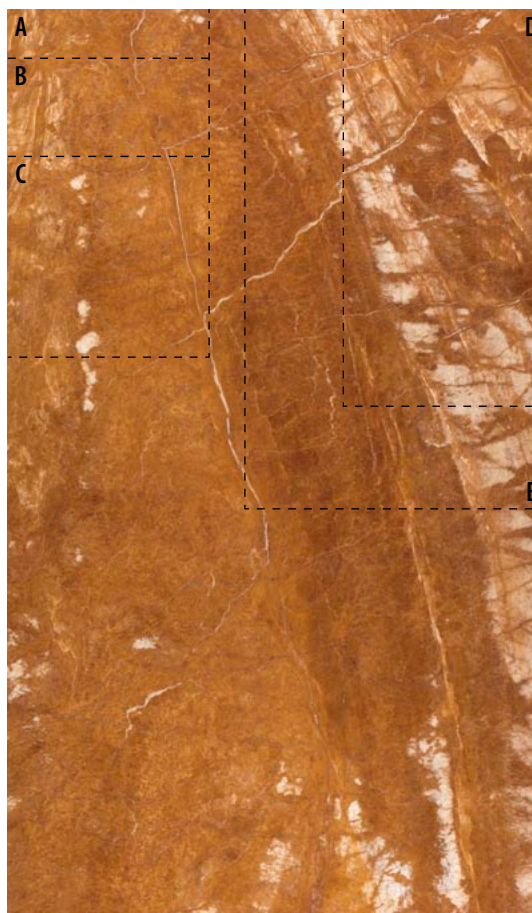

*Thickness:
minimum 2 cm · 3/4"*

Item A
15 x 60 cm · 5 7/8" x 23 5/8"

Item B
30 x 60 cm · 11 3/4" x 23 5/8"

Item C
60 x 60 cm · 23 5/8" x 23 5/8"

Item D
60 x 120 cm · 23 5/8" x 47 1/4"

Item E
90 x 150 cm · 35 3/8" x 59"

... and more

Small Scorpion

42,8 x 49,5 · 16 7/8" x 19 1/2"

Large Scorpion

61,3 x 87,9 · 24 1/8" x 34 5/8"

Misure riferite al solo mosaico.
Measures are referred to mosaic only.

The background of the entire page is a close-up of pink marbled paper. The marbling consists of soft, organic, vein-like patterns in various shades of pink, from pale blush to a more vibrant, slightly darker rose. The overall texture is delicate and artistic.

Pink

SICIS



Onice Rosa



Breccia Damascata



Rosa Portogallo



Rosa Pearl



Desert Pink



Rosa Aurora



Breccia Damascata Rosa

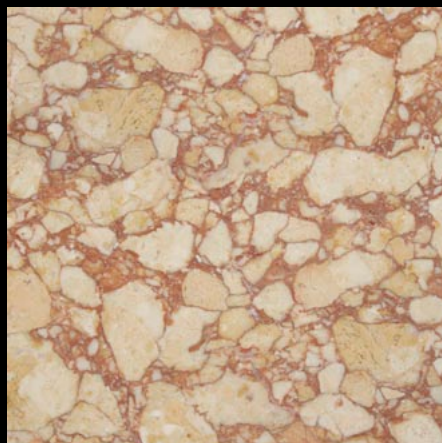

Rosalia Dark



Breccia Pernice

Onice Rosa





SICIS



Dalisa Pink
Onice Rosa

SICIS

Onice Rosa

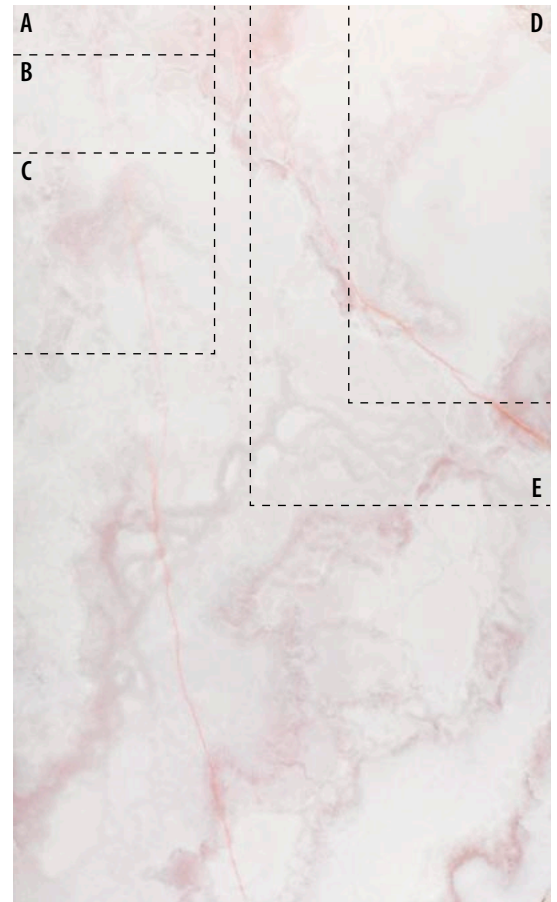
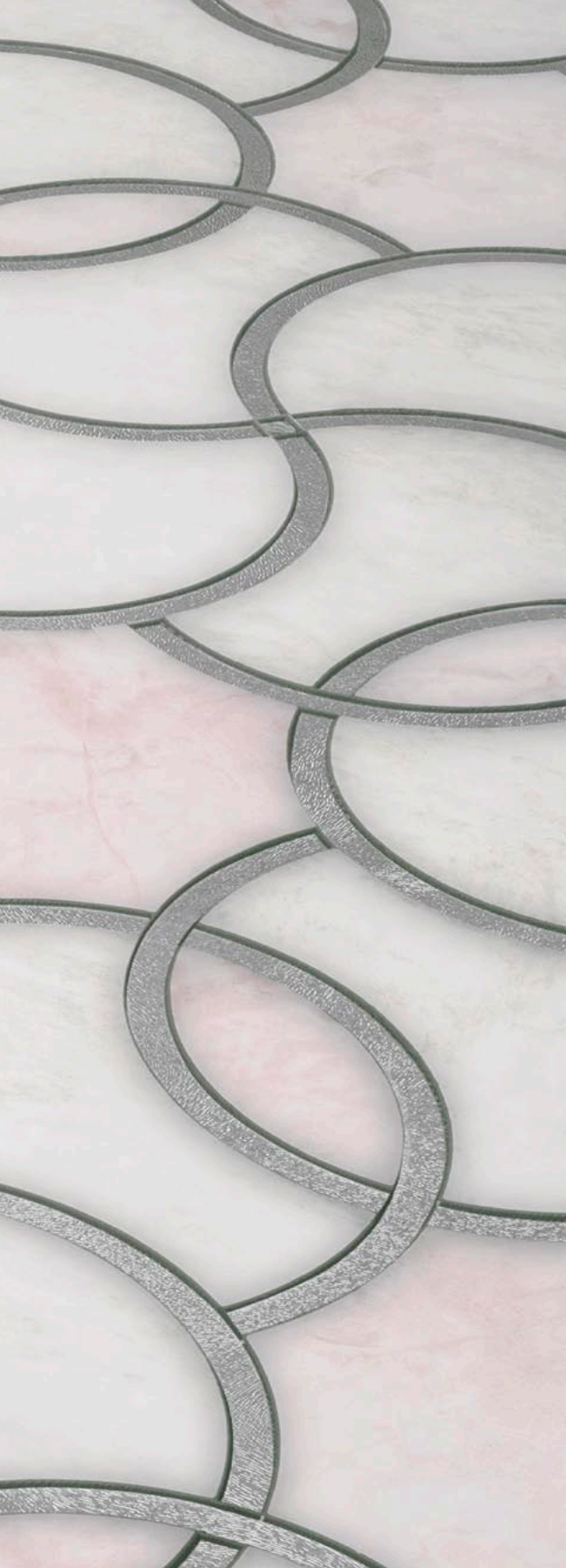

Item A
15 x 60 cm · 5^{7/8}" x 23^{5/8}"

Item B
30 x 60 cm · 11^{3/4}" x 23^{5/8}"

Item C
60 x 60 cm · 23^{5/8}" x 23^{5/8}"

Item D
60 x 120 cm · 23^{5/8}" x 47^{1/4}"

Item E
90 x 150 cm · 35^{3/8}" x 59"

... and more

Margaritas Pearl

Breccia Damascata Rosa

SICIS

Breccia Damascata Rosa



Item A
15 x 60 cm · 5^{7/8}" x 23^{5/8}"

Item B
30 x 60 cm · 11^{3/4}" x 23^{5/8}"

Item C
60 x 60 cm · 23^{5/8}" x 23^{5/8}"

Item D
60 x 120 cm · 23^{5/8}" x 47^{1/4}"

Item E
90 x 150 cm · 35^{3/8}" x 59"

... and more



Red

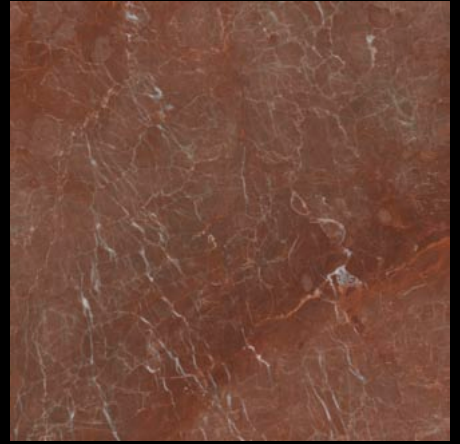

Tricot

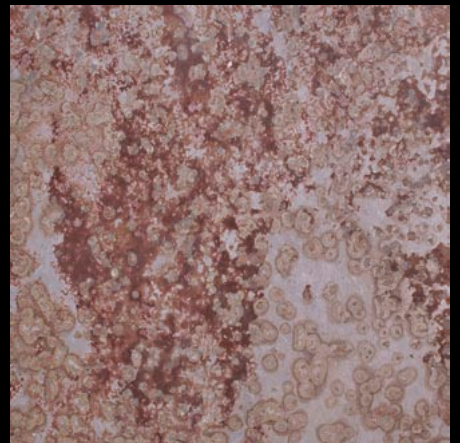

Ardesia Spectra

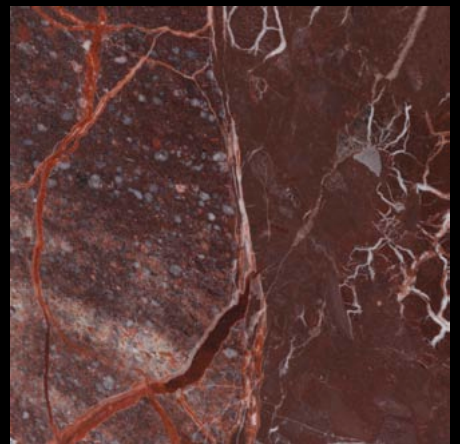

Rosso Levanto



Macchia Vecchia Rossa

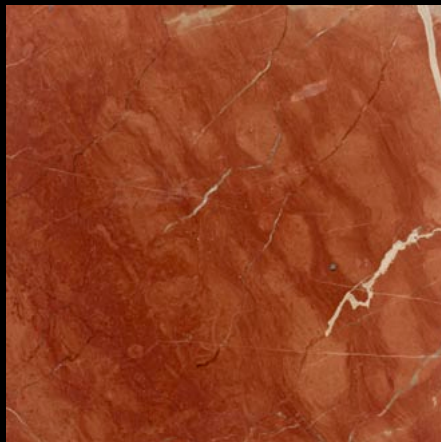

Rojo

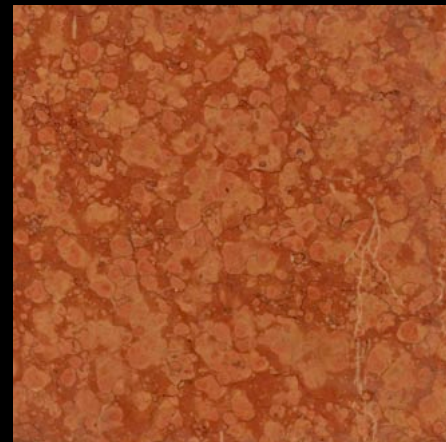

Rosso Verona



Onice Rosso

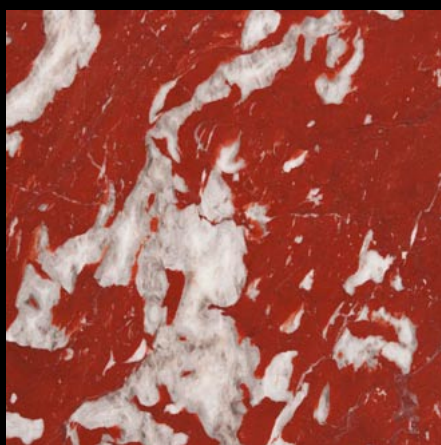

Rosso Francia

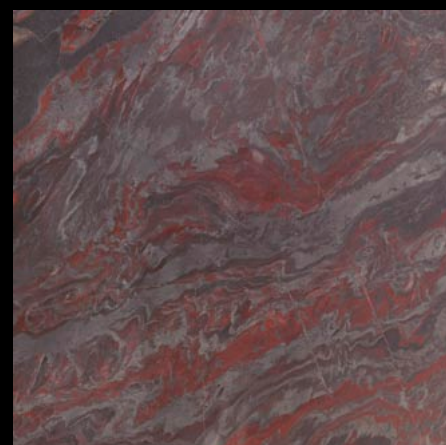

Iron Red



Red Lake

Jupiter Red



SICIS



Tricot

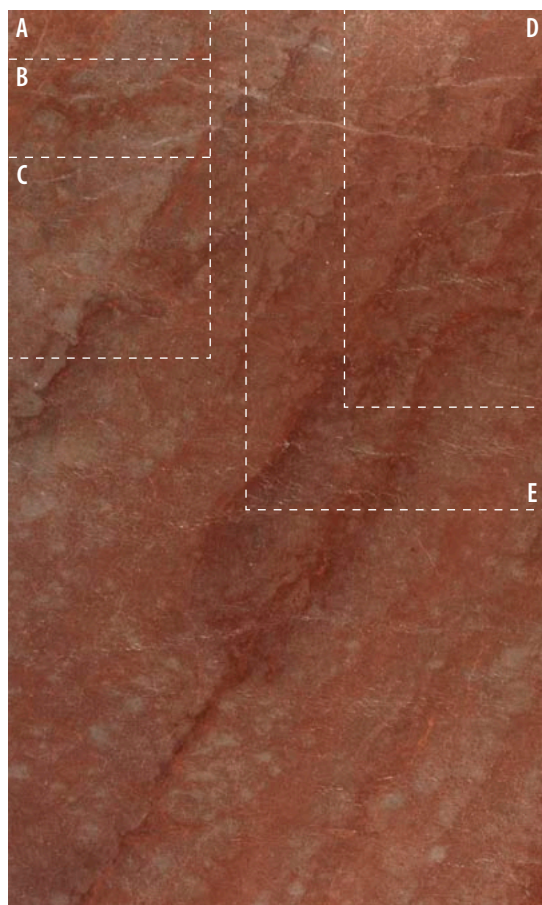

Item A
15 x 60 cm · 5 7/8" x 23 5/8"

Item B
30 x 60 cm · 11 3/4" x 23 5/8"

Item C
60 x 60 cm · 23 5/8" x 23 5/8"

Item D
60 x 120 cm · 23 5/8" x 47 1/4"

Item E
90 x 150 cm · 35 3/8" x 59"

... and more

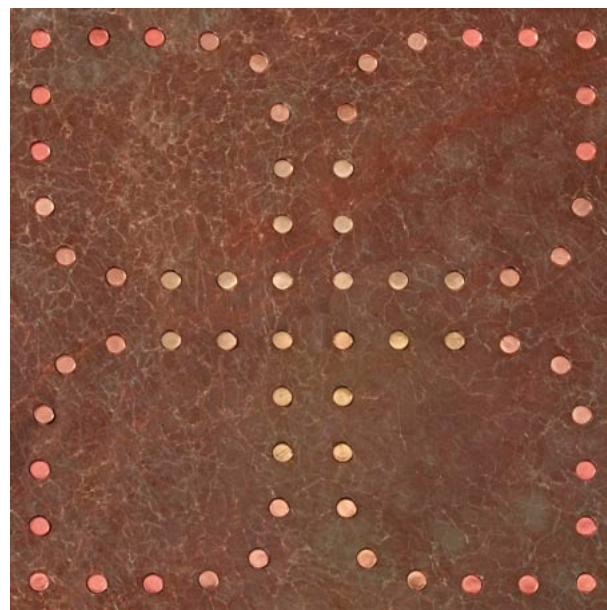

Galaver Module A
60 x 60 cm · 23 5/8" x 23 5/8"



Galaver Module B
60 x 60 cm · 23 5/8" x 23 5/8"

A black leather chair is positioned on a floor made of perforated metal plates. The floor has a grid pattern of small circular holes, which appear to glow with a reddish-orange light. The chair is in the upper right corner, and its reflection is visible on the floor. The overall scene is lit with dramatic, low-key lighting, emphasizing the textures of the leather and the perforated metal.

Galaver
Tricot

Meandros Red

Rosso Levanto



SICIS

Rosso Levanto

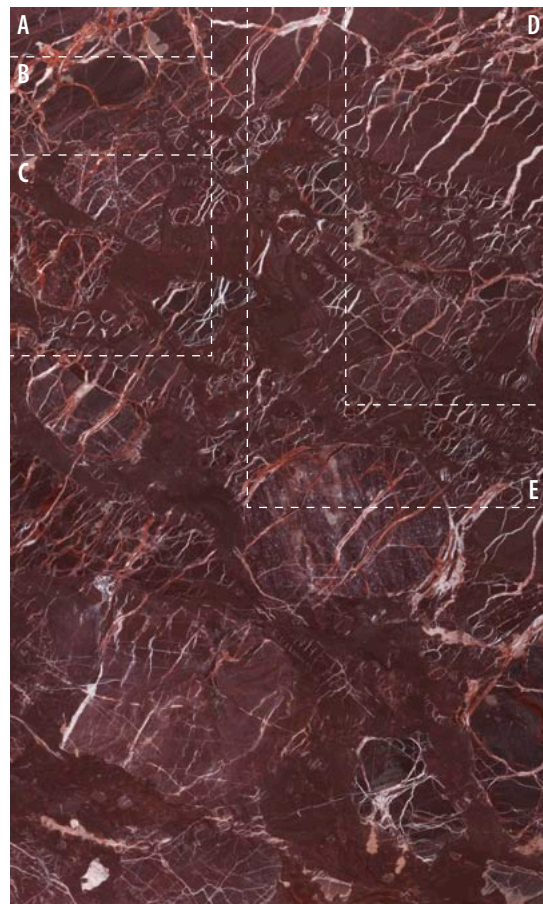

Item A
15 x 60 cm · 5^{7/8}" x 23^{5/8}"

Item B
30 x 60 cm · 11^{3/4}" x 23^{5/8}"

Item C
60 x 60 cm · 23^{5/8}" x 23^{5/8}"

Item D
60 x 120 cm · 23^{5/8}" x 47^{1/4}"

Item E
90 x 150 cm · 35^{3/8}" x 59"

... and more



Yarmony

SICIS

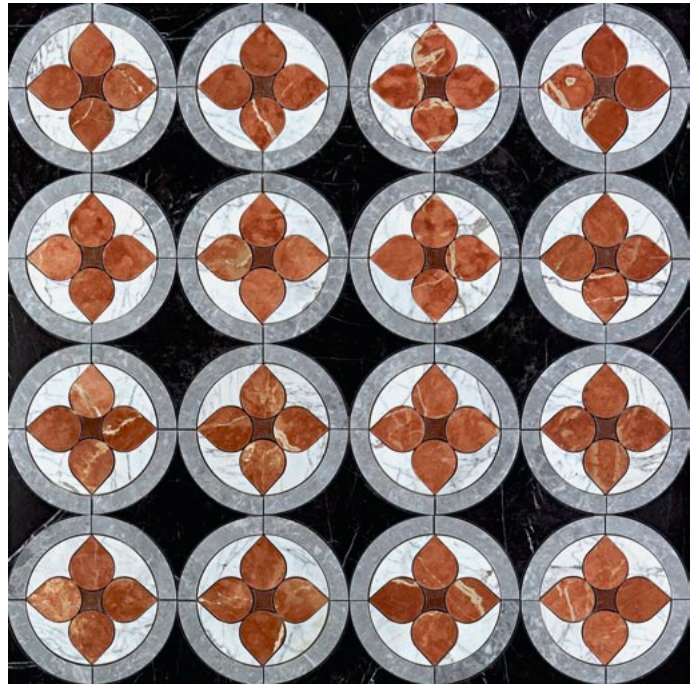

Yarmony

Clessidra Red



SICIS

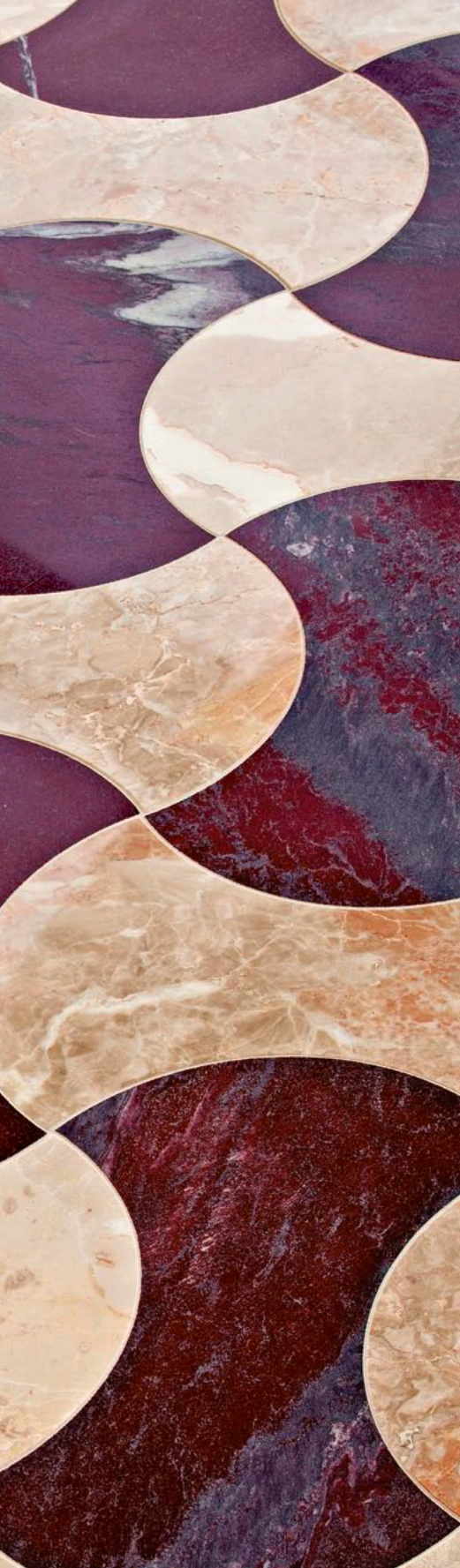

Clessidra Red



Sidonel Red



Travertino Dorato



Breccia Oniciata



Daino Reale

Brown



Amarelo Marlina

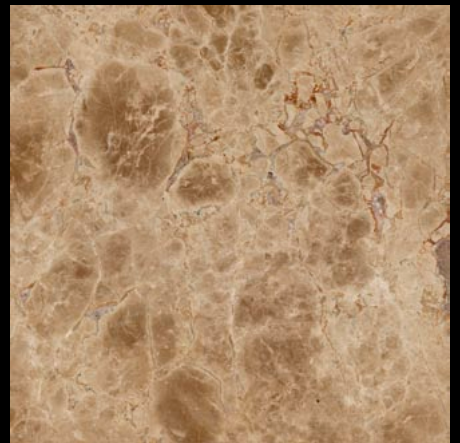

Emperador Light



Giallo Antico



Noce



Rainforest Gold



Cagica



Giallo Palmeiras



Golden Queen



Mascarello

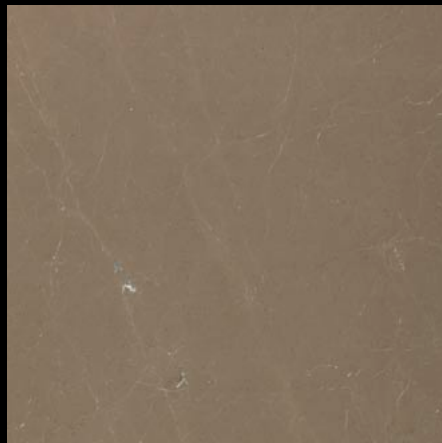

Avellana



Rainforest Brown



Breccia Nouvelle



Fossil Brown

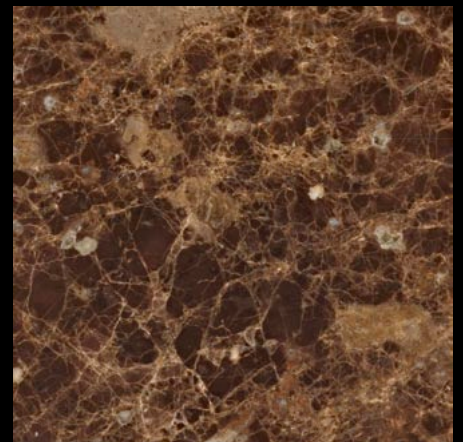

Emperador





© Revel Entertainment Group LLC - BLT Architects-Executive Architect and Architect of Record - SPA, Designed by CRAVE

SICIS









SICIS

Travertino Dorato

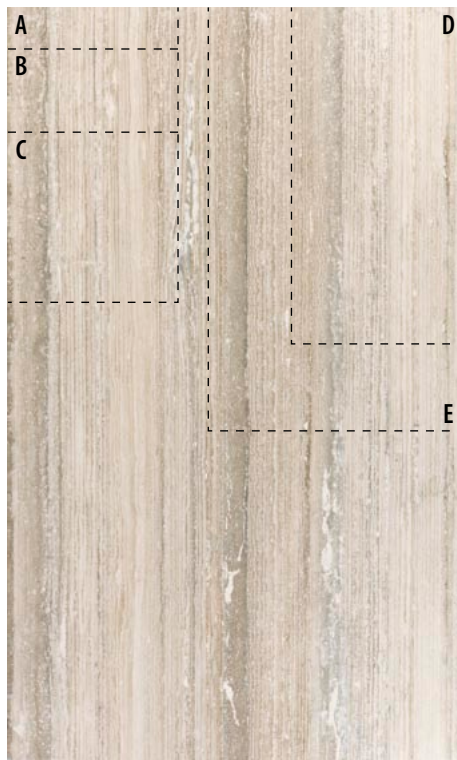

Item A

15 x 60 cm · 5 7/8" x 23 5/8"

Item B

30 x 60 cm · 11 3/4" x 23 5/8"

Item C

60 x 60 cm · 23 5/8" x 23 5/8"

Item D

60 x 120 cm · 23 5/8" x 47 1/4"

Item E

90 x 150 cm · 35 3/8" x 59"

... and more

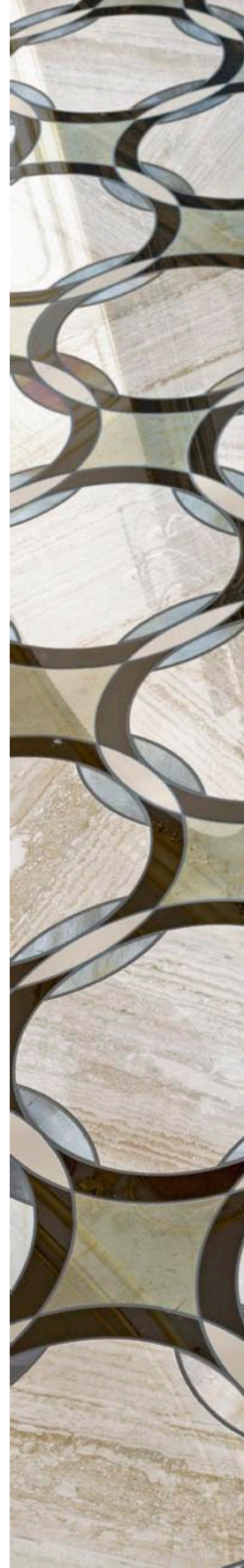



Milele Brown
Travertino Dorato

SICIS

Istan

SICIS



Istan



Inxert Brown



Salasco Brown

Seleris Pardo



Seleris Pardo





SICIS



Seleris Dark



SICIS

Randal Nut

Giallo Antico

SICIS

Giallo Antico



Item A
15 x 60 cm · 5 ⁷/₈" x 23 ⁵/₈"

Item B
30 x 60 cm · 11 ³/₄" x 23 ⁵/₈"

Item C
60 x 60 cm · 23 ⁵/₈" x 23 ⁵/₈"

Item D
60 x 120 cm · 23 ⁵/₈" x 47 ¹/₄"

Item E
90 x 150 cm · 35 ³/₈" x 59"

... and more

Avellana



Thickness:
minimum 2 cm · 3/4"

Item A
15 x 60 cm · 5 ⁷/₈" x 23 ⁵/₈"

Item B
30 x 60 cm · 11 ³/₄" x 23 ⁵/₈"

Item C
60 x 60 cm · 23 ⁵/₈" x 23 ⁵/₈"

Item D
60 x 120 cm · 23 ⁵/₈" x 47 ¹/₄"

Item E
90 x 150 cm · 35 ³/₈" x 59"

... and more



Vanart Avellana



SICIS

Yashila Avellana



Yashila



Snake

93,8 x 119,8 cm
36 ⁷/₈" x 47 ¹/₈"

Misure riferite
al solo mosaico.

*Measures are referred
to mosaic only.*

SICIS

Butterfly

Breccia Oniciata

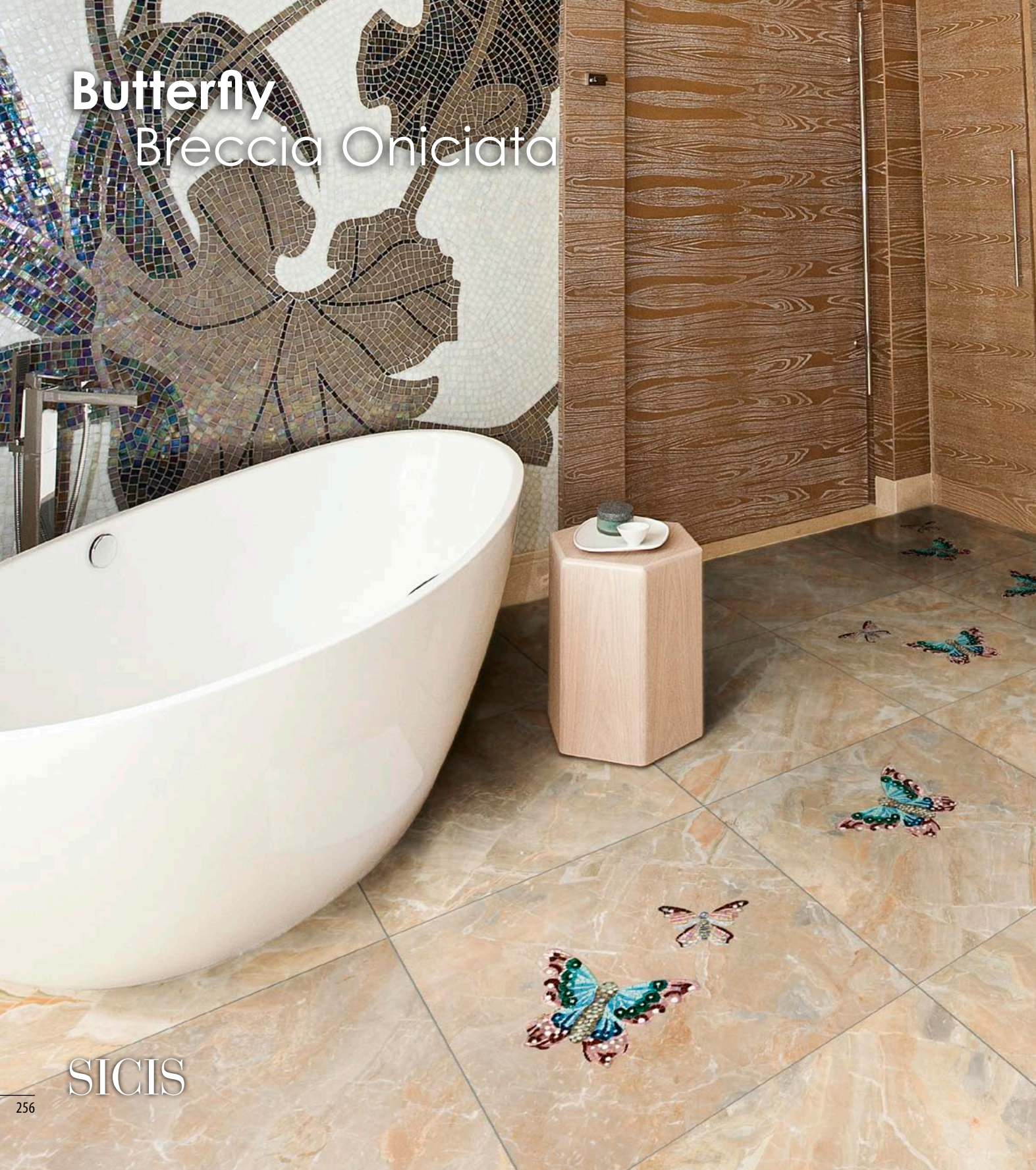

SICIS

Breccia Oniciata

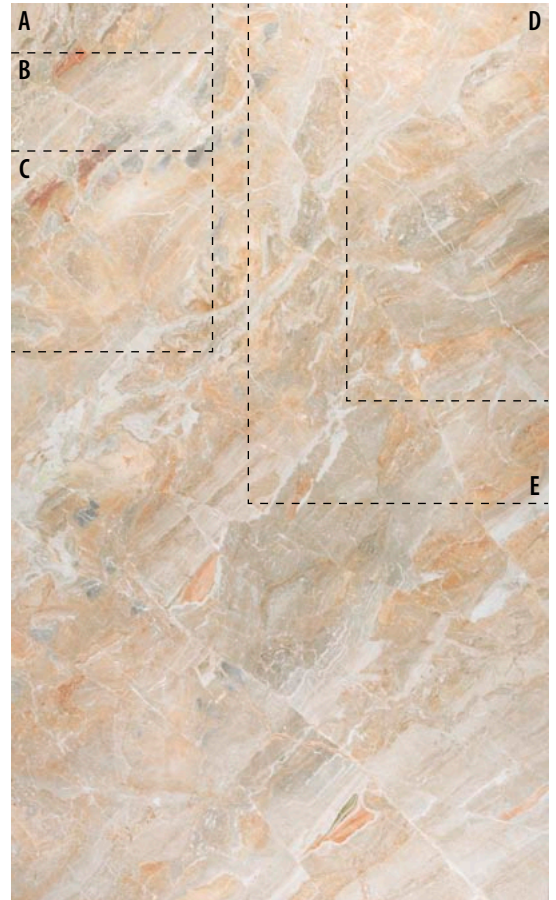

Small Butterfly
14,9 x 12,6 · 5^{7/8}" x 5"

Large Butterfly
26,4 x 21,5 · 10^{3/8}" x 8^{1/2}"

Misure riferite
al solo mosaico.
*Measures are referred
to mosaic only.*

Item A
15 x 60 cm · 5^{7/8}" x 23^{5/8}"

Item B
30 x 60 cm · 11^{3/4}" x 23^{5/8}"

Item C
60 x 60 cm · 23^{5/8}" x 23^{5/8}"

Item D
60 x 120 cm · 23^{5/8}" x 47^{1/4}"

Item E
90 x 150 cm · 35^{3/8}" x 59"

... and more

The background of the entire page is a detailed, high-resolution image of a charcoal-colored marble. The pattern consists of intricate, organic, and somewhat chaotic veins and swirls in shades of grey, taupe, and light beige, set against a darker charcoal base. The texture appears natural and stone-like.

Charcoal

SICIS



Fossil Green

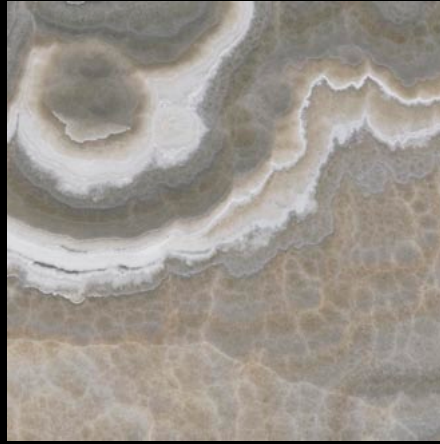

Onice Cappuccino



Fior di Bosco



Azul Marlena



Pietra Fossena



Beau Perle



Grafite

Fior di Bosco



Item A

15 x 60 cm · 5 7/8" x 23 5/8"

Item B

30 x 60 cm · 11 3/4" x 23 5/8"

Item C

60 x 60 cm · 23 5/8" x 23 5/8"

Item D

60 x 120 cm · 23 5/8" x 47 1/4"

Item E

90 x 150 cm · 35 3/8" x 59"

... and more





SICIS



SICIS

Olson Taupe



Olson Taupe

Seleris Brown

Onice Cappuccino



SICIS

Onice Cappuccino

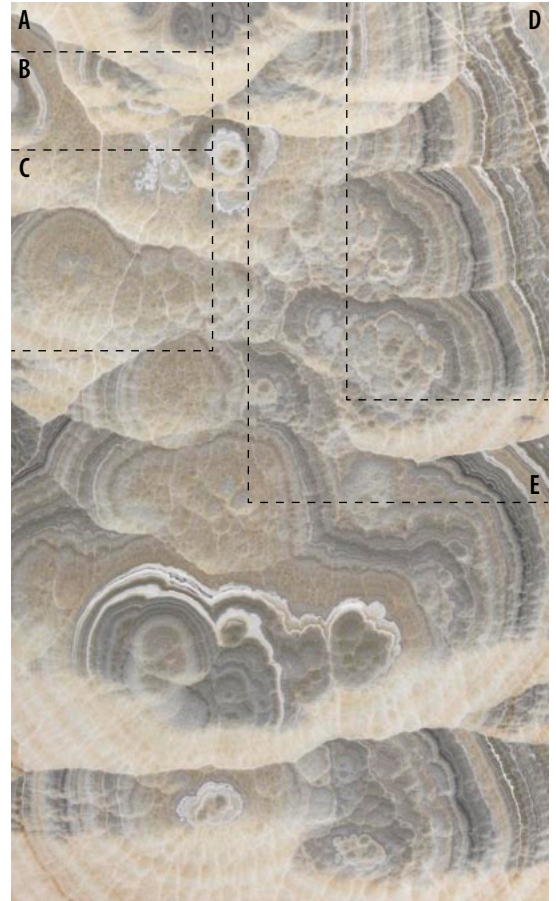

Item A
15 x 60 cm · 5^{7/8}" x 23^{5/8}"

Item B
30 x 60 cm · 11^{3/4}" x 23^{5/8}"

Item C
60 x 60 cm · 23^{5/8}" x 23^{5/8}"

Item D
60 x 120 cm · 23^{5/8}" x 47^{1/4}"

Item E
90 x 150 cm · 35^{3/8}" x 59"

... and more

Erbolarius Fossena



Erbolarius Fossena 1
48,7 x 32,9 cm · 19 ¹/₈" x 13"



Erbolarius Fossena 2
50,2 x 36,7 cm · 19 ³/₄" x 14 ¹/₃"



Erbolarius Fossena 3
86,8 x 58,3 cm · 34 ¹/₄" x 23"



Erbolarius Fossena 4
92,5 x 24,4 cm · 36 ³/₈" x 9 ⁵/₈"

Misure riferite al solo mosaico.
Measures are referred to mosaic only.



SICIS



Salasco Grey
Pietra Fossena

SICIS



Pietra Fossena

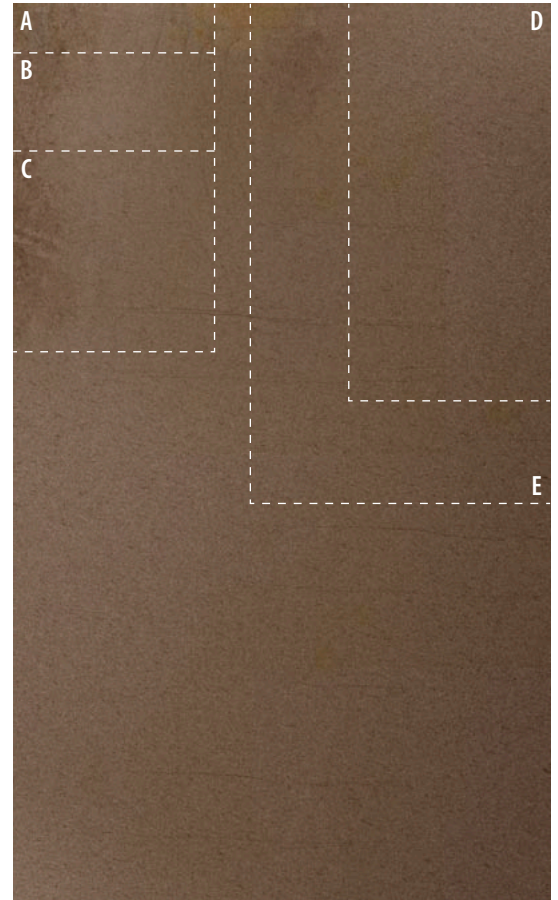

Item A
15 x 60 cm · 5^{7/8}" x 23^{5/8}"

Item B
30 x 60 cm · 11^{3/4}" x 23^{5/8}"

Item C
60 x 60 cm · 23^{5/8}" x 23^{5/8}"

Item D
60 x 120 cm · 23^{5/8}" x 47^{1/4}"

Item E
90 x 150 cm · 35^{3/8}" x 59"

... and more



SICIS

Trixel Grafite

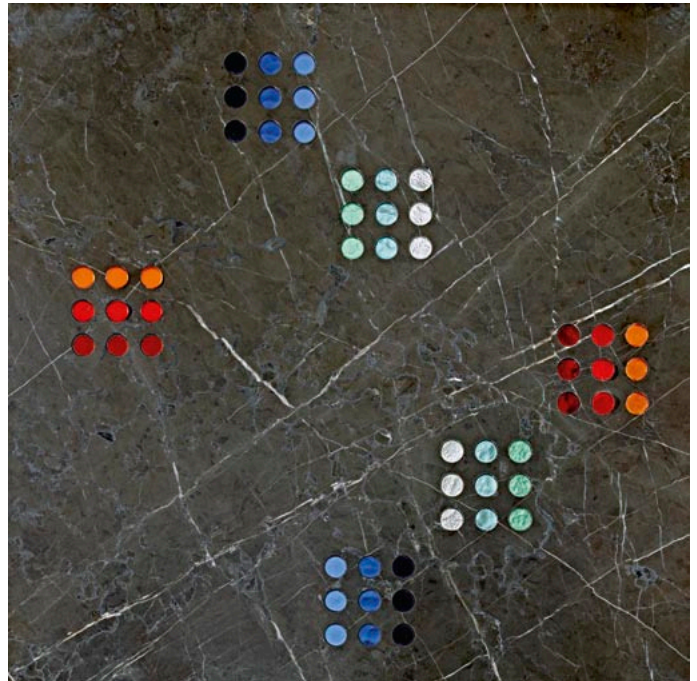

Trixel Module
60 x 60 cm · 23 5/8" x 23 5/8"

Grafite

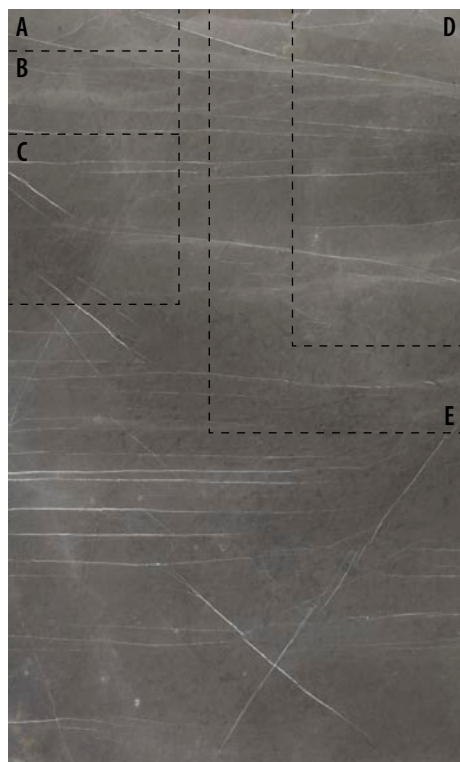

Item A

15 x 60 cm · 5 7/8" x 23 5/8"

Item B

30 x 60 cm · 11 3/4" x 23 5/8"

Item C

60 x 60 cm · 23 5/8" x 23 5/8"

Item D

60 x 120 cm · 23 5/8" x 47 1/4"

Item E

90 x 150 cm · 35 3/8" x 59"

... and more





Silhouettes





SICIS

Silhouettes

Size: 30,5 x 30,5 cm · 12" x 12"
 Thickness: 1 cm · 3/8"

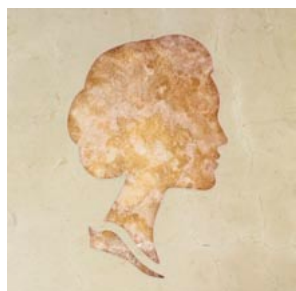

Silhouette Dama 2A
 Background: *Crema*
 Silhouette: *Onice Crema*

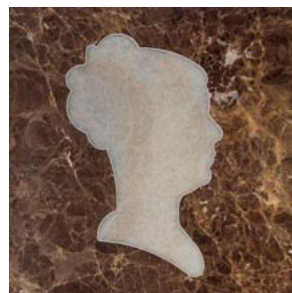

Silhouette Dama 1A
 Background: *Emperador*
 Silhouette: *Onice Cappuccino*



Silhouette Dama 2B
 Background: *Onice Spider White*
 Silhouette: *Onice Smeraldo*

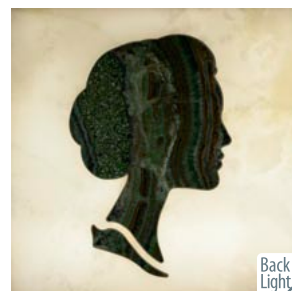

Silhouette Dama 3A
 Background: *Onice Spider White*
 Silhouette: *Nero*

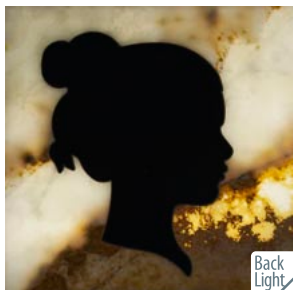

Silhouette Dama 4A
 Background: *Azul Marlina*
 Silhouette: *Onice Cappuccino*



Silhouette Dama 5A
 Background: *Onice Spider White*
 Silhouette: *Nero*

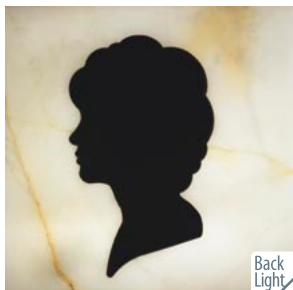

Silhouette Dama 6A
 Background: *Verde*
 Silhouette: *Onice Verde Dark*

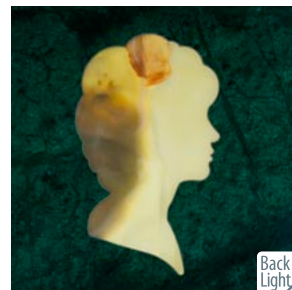



Silhouette Uomo 1A
Background: *Onice Golden*
Silhouette: *Emperador*



Silhouette Uomo 1B
Background: *Onice Spider White*
Silhouette: *Onice Rosso*

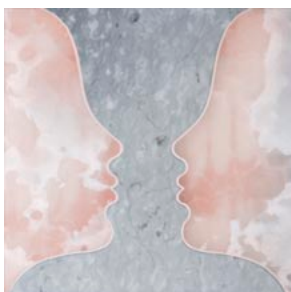
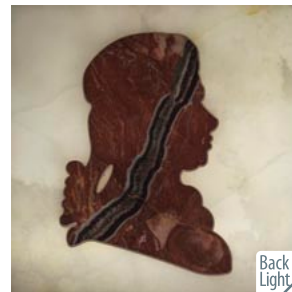

Silhouette Incontro 1A
Background: *Bardiglietto*
Silhouette: *Onice Rosa*

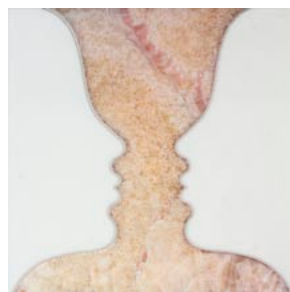
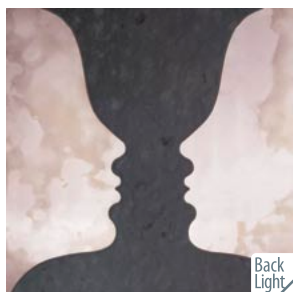

Silhouette Incontro 1B
Background: *Onice Golden*
Silhouette: *Thassos*

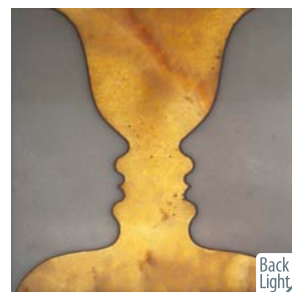

Silhouette Budda 1A
Background: *Onice Cappuccino*
Silhouette: *Bardiglio*

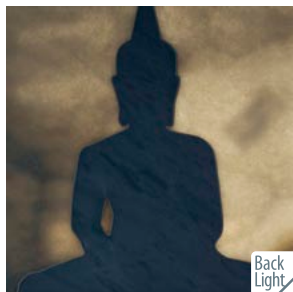

Silhouette Budda 1B
Background: *Onice Rosso*
Silhouette: *Onice Rosa*

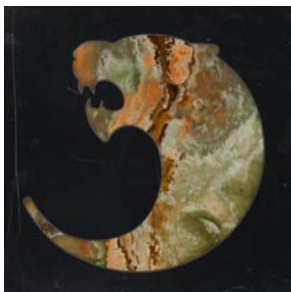
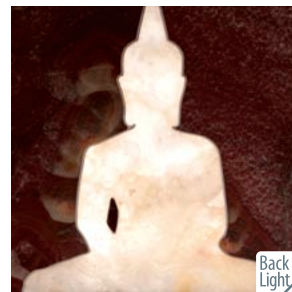

Silhouette Pantera 1A
Background: *Nero*
Silhouette: *Onice Verde Dark*

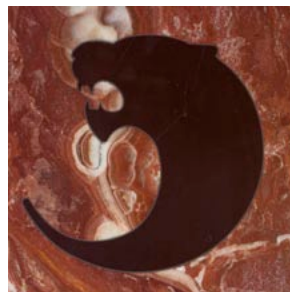

Silhouette Pantera 1B
Background: *Onice Rosso*
Silhouette: *Nero*

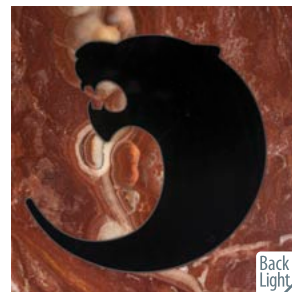



Silhouette Farfalla 1A
Background: *Thassos*
Silhouette: *Onice Smeraldo*



Silhouette Farfalla 1B
Background: *Olive*
Silhouette: *Onice Spider White*

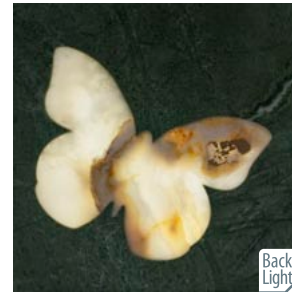

Silhouette Farfalla 2A
Background: *Statuario*
Silhouette: *Onice Rosso & Onice Verde Dark*



Silhouette Farfalla 2B
Background: *Verde Luna*
Silhouette: *Onice Crema*

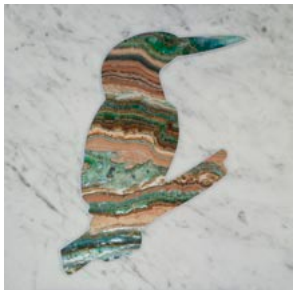

Silhouette Martin 1A
Background: *Bianco Carrara*
Silhouette: *Onice Smeraldo*



Silhouette Martin 2A
Background: *Onice Spider White*
Silhouette: *Onice Crema*

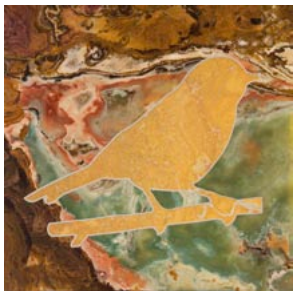
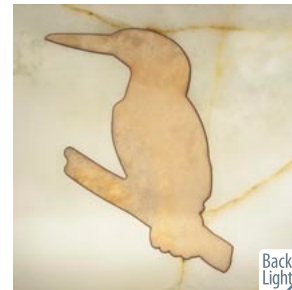

Silhouette Usignolo 1A
Background: *Onice Verde Dark*
Silhouette: *Gold Travertine*



Silhouette Usignolo 1B
Background: *Red Lake*
Silhouette: *Onice Spider White*

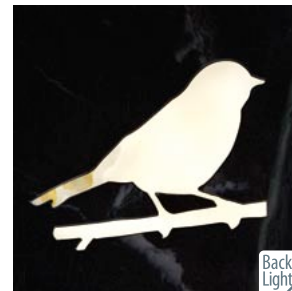



Silhouette Farfalla 1C

Background: *Onice Crema*
Silhouette: *Onice Spider White*



Silhouette Teschio 1A

Background: *Nero*
Silhouette: *Onice Golden*

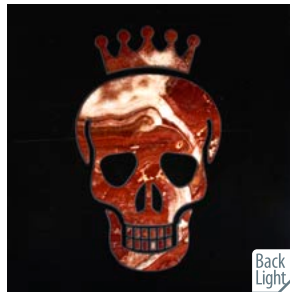

Silhouette Teschio 1B

Background: *Nero*
Silhouette: *Onice Rosso*



Silhouette Teschio 1C

Background: *Thassos*
Silhouette: *Onice Rosa*



Shower trays





Shower trays

by carved stone

Disponibile in tutte le dimensioni
e su richiesta in altri marmi come da catalogo.
*Available in all dimensions and
on request in other marbles of our catalogue.*

Shower Tray
01 Crema



Size:
124 x 94 h 10 cm
48 7/8" x 37" h 3 7/8"

Shower Tray
02 Bianco Antico



Size:
120 x 117 h 10 cm
47 1/4" x 46 1/8" h 3 7/8"

Shower Tray
03 Crema



Size:
114 x 104 h 10 cm
44 7/8" x 41" h 3 7/8"

Shower Tray
03 Emperador

SICIS

Size: 124 x 110 h 10 cm
48 7/8" x 43 1/4" h 3 7/8"



OPTION: Radiant heated
Shower Tray

Details & instructions available in
www.sicis.com



Back detail





Marmoteca



SICIS

Marmoteca

* Spessore disponibile
Available thickness:
1 cm, 2 cm, 3 cm
3/8", 3/4", 1 1/8"

** Spessore disponibile
Available thickness:
2 cm, 3 cm
3/4", 1 1/8"



Aghia Marina
**

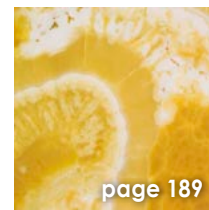

Alabastro Egiziano
**

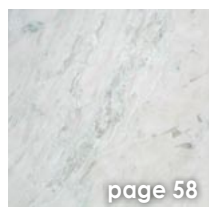

Alba Chiara
*

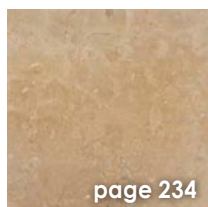

Amarelo Marlina
*



Ambra Gold
**



Anastasia
*

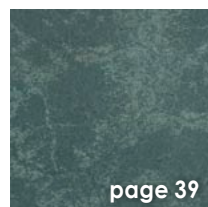

Antique Green
**

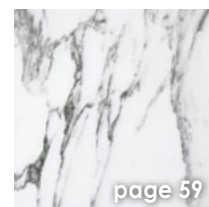

Arabescato Carrara
*



Ardesia Spectra
*

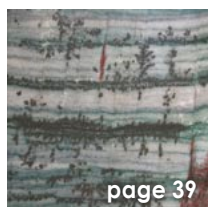

Arlecchino
**



Avellana
**

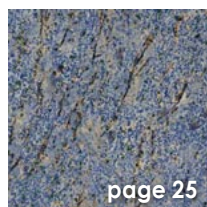

Azul Bahia
*

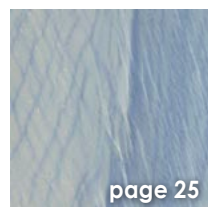

Azul Macauba
*



Azul Marlina
*



Baikal Rock
*

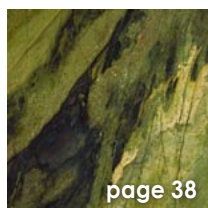

Bamboo Green
**

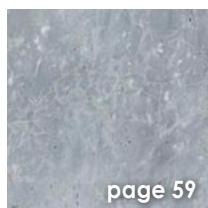

Bardiglietto
*

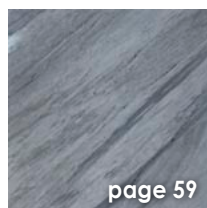

Bardiglio
*

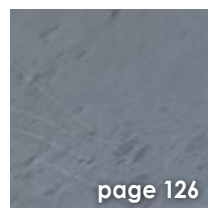

Bardiglio Imperiale
*

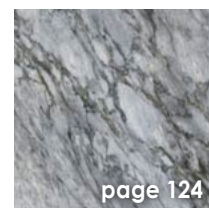

Bardiglio Orientale
*



Beau Perle
*

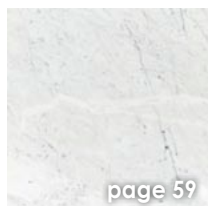

Bianco Americano
*

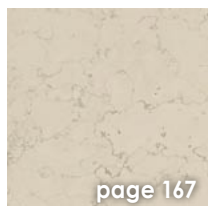

Bianco Antico
*

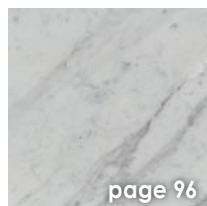

Bianco Carrara
*

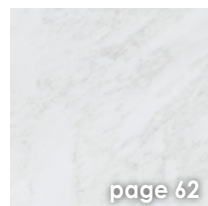

Bianco Namibia
*

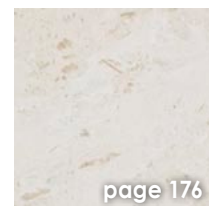

Bianco Perlato
*

I materiali qui rappresentati sono soggetti a variazioni di colore e disegno essendo prodotti naturali.
Nessuna responsabilità potrà essere attribuita a Sisis per errori oppure omissioni riguardanti i dati tecnici dei materiali e dei loro colori.

*The materials shown here are subject to variations in colour and grain, as they are natural products.
Sisis is not responsible for any mistake or omission about technical data and their colours.*

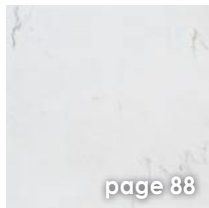

page 88

Bianco Sivec
**



page 167

Botticino
*

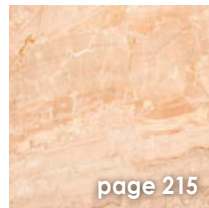

page 215

Breccia Damascata
*

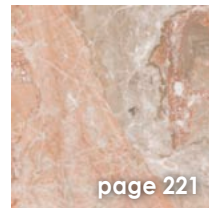

page 221

Breccia Damascata
Rosa *

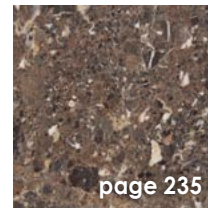

page 235

Breccia Nouvelle
*

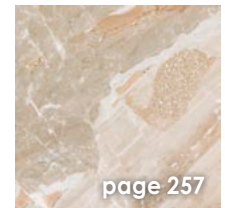

page 257

Breccia Oniciata
*

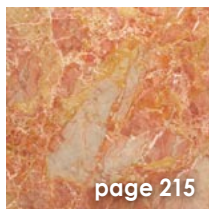

page 215

Breccia Pernice
*



page 213

Briar Wood
**



page 235

Cagica
**

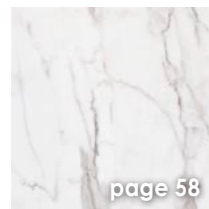

page 58

Calacatta
*

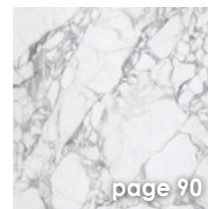

page 90

Calacatta Vagli
*

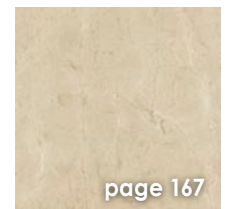

page 167

Crema
*



page 234

Daino Reale
*

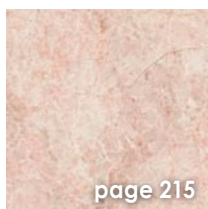

page 215

Desert Pink
*

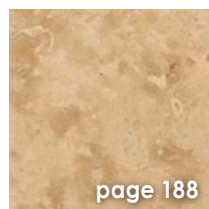

page 188

Dore Royal
*



page 146

Ebony Black
*



page 235

Emperador
*



page 234

Emperador Light
*



page 260

Fior di Bosco
*



page 235

Fossil Brown
*



page 259

Fossil Green
*

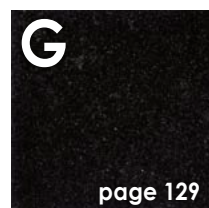

page 129

Galaxy Black
*

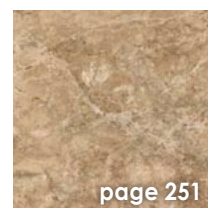

page 251

Giallo Antico
*



page 235

Giallo Palmeiras
*

Marmoteca

* Spessore disponibile
Available thickness:
1 cm, 2 cm, 3 cm
3/8", 3/4", 1 1/8"

* * Spessore disponibile
Available thickness:
2 cm, 3 cm
3/4", 1 1/8"



Giallo Royal
*

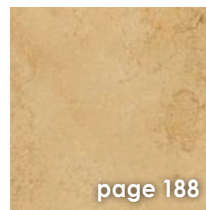

Gold Byzantine
*

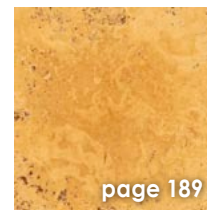

Gold Travertine
*

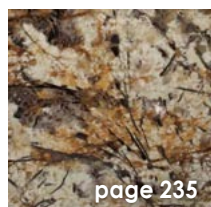

Golden Queen
**



Golden Spider
*



Grafite
*

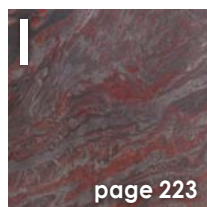

Iron Red
**



Jaune du Roi
*

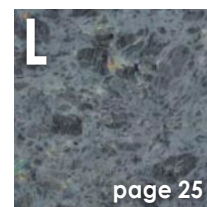

Labradorite
Multicolor *



Macchia Vecchia
Rossa **



Mascarello
**

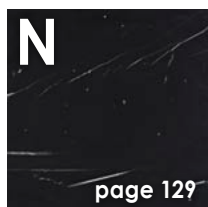

Nero
*

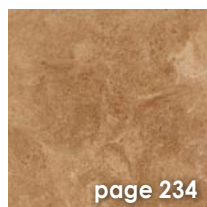

Noce
*

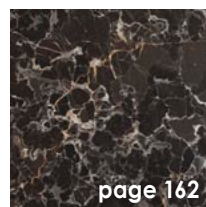

Noir Saint Laurent
*



Olive
*

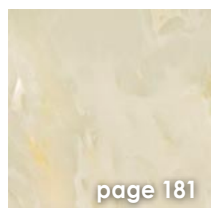

Onice Bianco
*

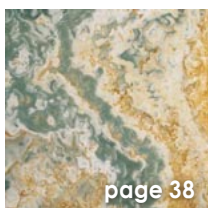

Onice Blue
**



Onice Cappuccino
*

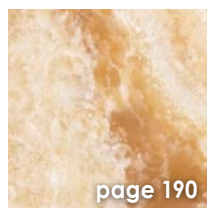

Onice Crema
*



Onice Golden
*

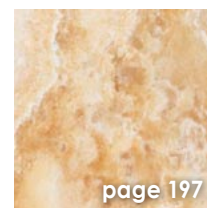

Onice Miele
*

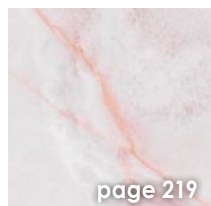

Onice Rosa
*

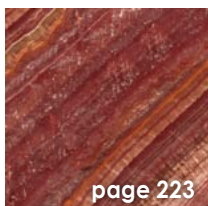

Onice Rosso
*

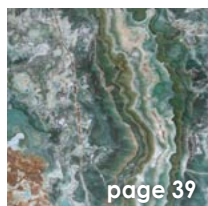

Onice Smeraldo
*

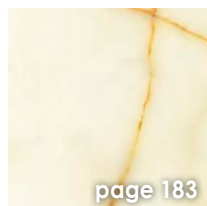

Onice Spider White
*



Onice Verde Dark
*

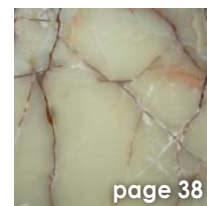

Onice Verde Light
*



P

page 269

Pietra Fossena

*

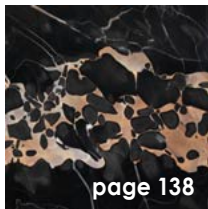

page 138

Portoro Extra

**

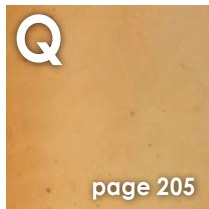

Q

page 205

Quarzite Gialla

*



R

page 235

Rainforest Brown

*



page 234

Rainforest Gold

*

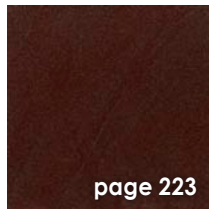

page 223

Red Lake

*

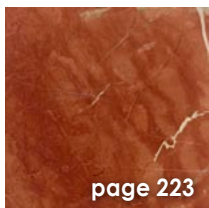

page 223

Rojo

*



page 215

Rosa Aurora

*

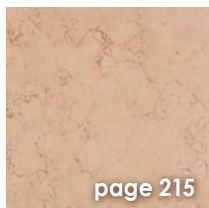

page 215

Rosa Pearl

*



page 215

Rosa Portogallo

*

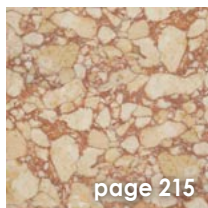

page 215

Rosalia Dark

*

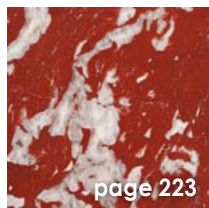

page 223

Rosso Francia

*



page 229

Rosso Levanto

*



page 223

Rosso Verona

*



S

page 29

Sodalite Blue

*

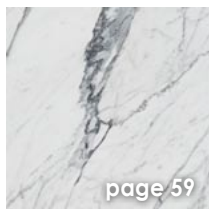

page 59

Statuarietto

*

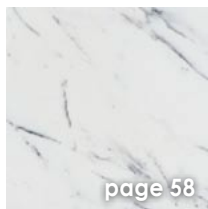

page 58

Statuario

*

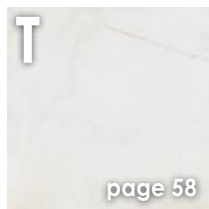

page 58

Thassos

*

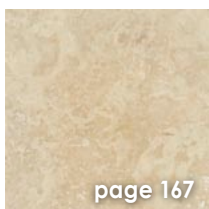

page 167

Travertino

*



page 242

Travertino Dorato

*

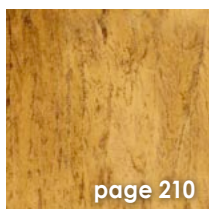

page 210

Travertino Giallo

*



page 226

Tricot

*

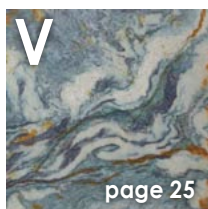

V

page 25

Van Gogh

**

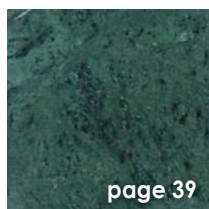

page 39

Verde

*

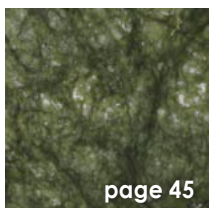

page 45

Verde Giada

*

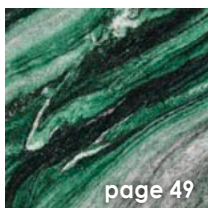

page 49

Verde Lapponia

*



page 39

Verde Luna

*



page 38

Verde Namibia

*



Y

page 189

Yellow Sunset

*

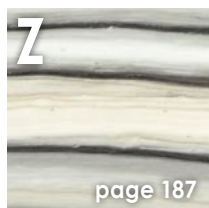

page 187

Zebrino

*

Decor Index

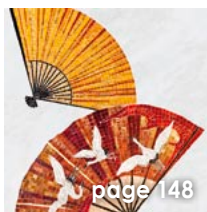

Abanicos
Marble & Glass Mosaic



Aguamiel Beige
Marble: *Bianco Antico, Crema, Desert Pink*
Glass: *MS Beige Iridescent, Fentas, Platinum*



Algar Grey
Marble: *Grafite, Nero, Zebrino*
Glass: *Vis One*



Alia Black
Marble: *Bianco Namibia, Ebony Black*
Glass: *Alma*

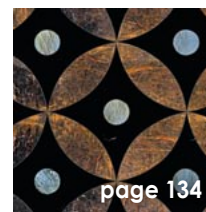

Alia Brown
Marble: *Baikal Rock, Ebony Black*
Glass: *Platinum*



Alia White
Marble: *Statuario, Thassos*
Glass: *Icemir*

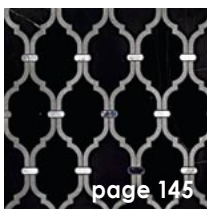

Aloina Black
Marble: *Nero, Nero Ancient*
Glass: *Alma, Vis One*



Aloina White
Marble: *Bianco Americano, Thassos*
Glass: *Gold*

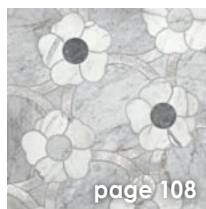

Amapola Grey
Marble: *Bardiglio, Bianco Carrara, Statuario*
Glass: *Vis One*



Amidele BE
Marble: *Onice Bianco, Onice Rosa*
Glass: *MS Beige Iridescent*

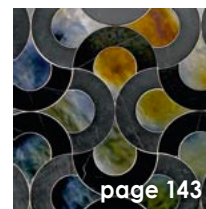

Amidele BL
Marble: *Nero, Nero Ancient*
Glass: *MS Black Iridescent*



Amidele WH
Marble: *Bianco Americano, Statuario, Thassos*

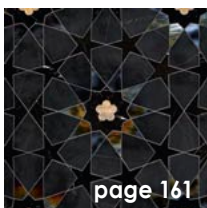

Andalusì Black
Marble: *Nero, Nero Ancient*
Glass: *MS Black Iridescent, Platinum*

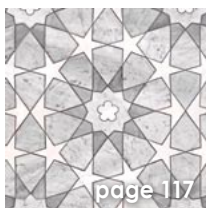

Andalusì Grey
Marble: *Bardiglietto, Bianco Carrara*
Glass: *MS White Iridescent*



Andalusì Ocra
Marble: *Emperador, Jaune du Roi*
Glass: *Kaki*



Andel Blue
Marble: *Nero*
Glass: *Alluminium, Amaril 2, Athena, Hermes, Kori, Zorat*



Anemil Grey
Marble: *Bianco Carrara, Artistic Mosaic*
Glass: *Alma, Icemir, Kawat, Marver*



Anzis Marble Beige
Marble: *Crema*
Glass: *Golden Tide*



Aquarium
Marble: *Bianco Namibia, Bardiglietto, Bianco Carrara*
Glass: *Artistic Mosaic*



Aquarium Yellow
Marble: *Noir Saint Laurent, Bardiglietto, Bianco Carrara*
Glass: *Artistic Mosaic*

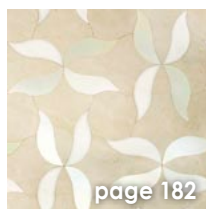

Azahar Beige
Marble: *Onice Spider White, Crema*
Glass: *MS Beige Iridescent*

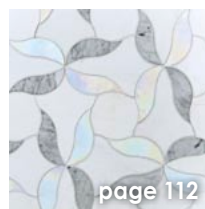

Azahar Irid
Marble: *Bianco Americano, Thassos*
Glass: *MS White Iridescent*

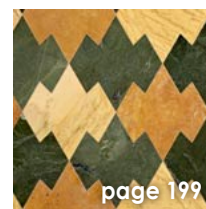

Azetek Ocra
Marble: *Gold Travertine, Jaune du Roi, Olive*

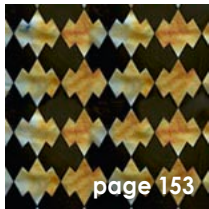

page 153

Azetek Small Black

Marble: *Nero*
Glass: *MS Black Iridescent*



B

page 126

Buggy

Marble: *Bardiglio Imperiale*
Glass: *Artistic Mosaic*

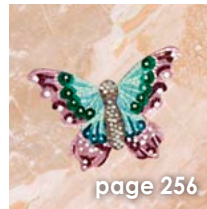

page 256

Butterfly

Marble: *Breccia Oniciata*
Glass: *Artistic Mosaic*



C

page 172

Cadeia Crema

Marble: *Azul Marlena, Bianco Antico, Sodalite Blue*
Glass: *MS Beige Iridescent*



page 193

Caleidos Beige

Marble: *Gold Byzantine, Crema, Bianco Antico*
Glass: *MS Beige Iridescent*

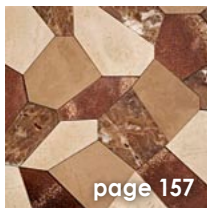

page 157

Caleidos Brown

Marble: *Crema, Amarelo Marlena, Emperador Light*
Glass: *Vis Two*

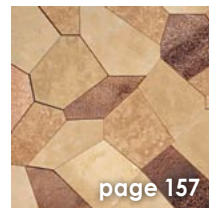

page 157

Caleidos Caramel

Marble: *Amarelo Marlena, Amarelo Marlena Ancient, Noce Ancient*
Glass: *Vis Two*

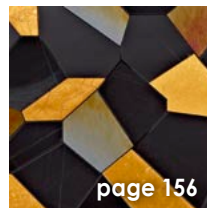

page 156

Caleidos Gold

Marble: *Nero, Nero Ancient*
Glass: *MS Black Iridescent, Gold*



page 157

Caleidos Grey

Marble: *Bianco Carrara, Bardiglietto, Bardiglio*
Glass: *Icemir*

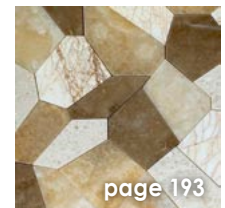

page 193

Caleidos Onix

Marble: *Bianco Perlato, Emperador Light, Golden Spider, Onice Crema, Onice Miele*

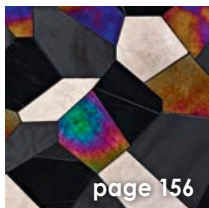

page 156

Caleidos Platinum

Marble: *Nero, Nero Ancient*
Glass: *MS Black Iridescent, Platinum*

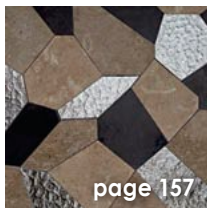

page 157

Caleidos Tobacco

Marble: *Azul Marlena, Azul Marlena Ancient, Nero Ancient*
Glass: *Hermes*



page 161

Califa Black

Marble: *Nero, Nero Ancient*
Glass: *MS Black Iridescent, Gold*



page 117

Califa White

Marble: *Statuario, Bianco Carrara*
Glass: *MS White Iridescent*



page 46

Celosin Green

Marble: *Olive, Nero, Verde Luna*
Glass: *MS White Iridescent*



page 30

Cetrix White

Marble: *Bianco Americano, Thassos, Statuario, Azul Macauba, Verde Luna*
Glass: *Platinum, Gold*



page 194

Clessidra Crema

Marble: *Onice Crema, Travertino*

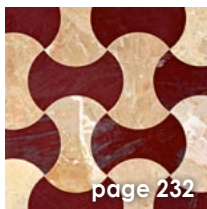

page 232

Clessidra Red

Marble: *Breccia Damascata, Red Lake*



page 152

Clessidra Small Black

Marble: *Nero*
Glass: *MS Black Iridescent*



D

page 81

Dalisa Grey

Marble: *Bianco Americano, Statuario, Thassos*
Glass: *Gold*



page 218

Dalisa Pink

Marble: *Onice Rosa, Bianco Namibia*
Glass: *Vis One*

Decor Index



page 208

Delicatissimum BEC1

Marble: *Crema, Artistic Mosaic*
Glass: *MS Beige Iridescent, Kori*

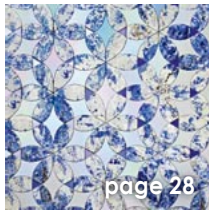

page 28

Delicatissimum BEC2

Marble: *Sodalite Blue*
Glass: *MS Beige Iridescent, Tanzanite*



page 209

Delicatissimum BEC3

Marble: *Crema, Sodalite Blue*
Glass: *MS Beige Iridescent, Tanzanite*

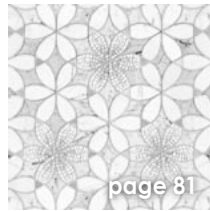

page 81

Delicatissimum WH

Marble: *Bianco Carrara, Statuario, Artistic Mosaic*
Glass: *Vis One*



page 81

Delicatissimum WHC

Marble: *Thassos, Statuario*
Glass: *Ruby*



page 100

Dragon

Marble: *Bianco Carrara*
Glass: *Artistic Mosaic*



page 142

Dralis Black

Marble: *Nero, Nero Ancient*
Glass: *MS Black Iridescent*

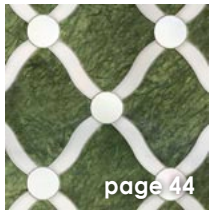

page 44

Dralis Green

Marble: *Verde Giada, Onice Bianco*
Glass: *MS Beige Iridescent*



page 81

Dralis White

Marble: *Bianco Americano, Thassos*

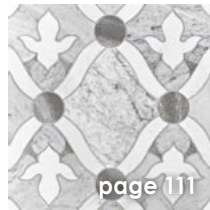

page 111

Dralis Flor Grey

Marble: *Bianco Americano, Thassos*
Glass: *Vis One*



E



page 122

Ebrick

Marble & Glass



page 108

Elecos Irid

Marble: *Bianco Americano, Statuario*
Glass: *MS White Iridescent, Vis One, Alma*

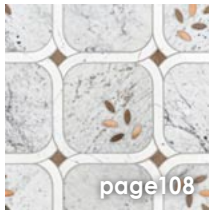

page 108

Elecos Kaki

Marble: *Bianco Americano, Statuario*
Glass: *Vis Two, Kaki*

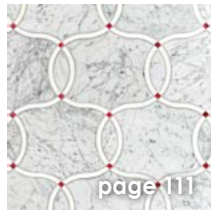

page 111

Enlaxo White

Marble: *Bianco Americano, Thassos*
Glass: *Ruby*



page 76

Erbolarius Americano

Marble: *Bianco Americano*
Glass: *Artistic Mosaic*

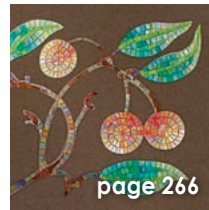

page 266

Erbolarius Fossena

Marble: *Pietra Fossena*
Glass: *Artistic Mosaic*



F

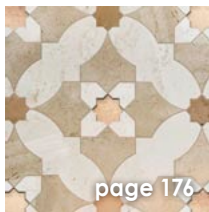

page 176

Feras BE

Marble: *Bianco Perlato, Rosa Pearl, Crema*
Glass: *Kaki 3*



page 81

Feras GR

Marble: *Bardiglietto, Statuario*
Glass: *Chantal, Tharsis*

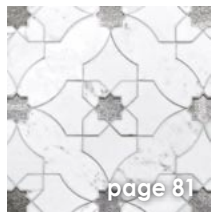

page 81

Feras WH

Marble: *Thassos, Statuario*
Glass: *Vis One*

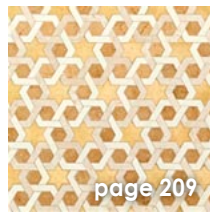

page 209

Firmamentus BEC

Marble: *Crema, Gold Byzantine*
Glass: *Kori, MS Beige Iridescent*

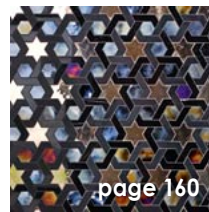

page 160

Firmamentus BLC

Marble: *Nero, Nero Ancient*
Glass: *MS Black Iridescent, Platinum*



page 111

Firmamentus GR

Marble: *Thassos, Bianco Carrara, Bardiglietto*
Glass: *MS White Iridescent*

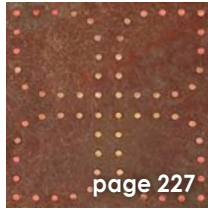

page 227

Galaver

Marble: *Tricot*
Glass: *Selmak 4, Fentas, Kaki 3*

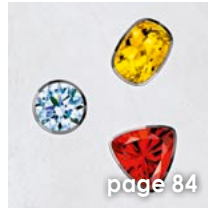

page 84

Gemstones

Marble & Colored Glass

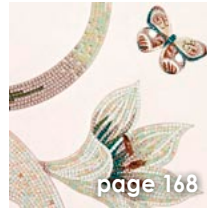

page 168

Gilius Beige

Marble: *Anastasia*
Glass: *Artistic Mosaic*



page 79

Gilius Grey

Marble: *Bianco Carrara*
Glass: *Artistic Mosaic*



page 78

Gilius White

Marble: *Bianco Namibia*
Glass: *Artistic Mosaic*



page 200

Gironda Golden

Marble: *Onice Golden, Crema*
Glass: *Kori*

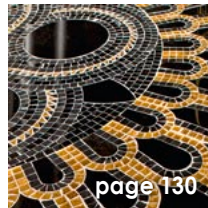

page 130

Heliantus B&G

Marble: *Nero, Nero Ancient*
Glass: *Gold*



page 113

Heliantus GR

Marble: *Bianco Carrara, Bardiglio,*
Artistic Mosaic
Glass: *Platinum*

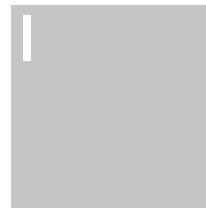

page 48

Iberis Green

Marble: *Verde Lapponia,*
Botticino, Onice Rosa



page 111

Iberis White

Marble: *Bianco Americano,*
Thassos
Glass: *Vis One*

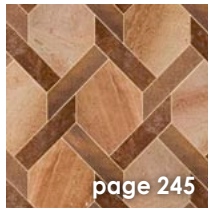

page 245

Inxert Brown

Marble: *Emperador Light,*
Daino Reale
Glass: *Vis Two*

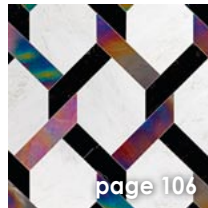

page 106

Inxert White

Marble: *Bianco Namibia, Nero*
Glass: *MS Black Iridescent*

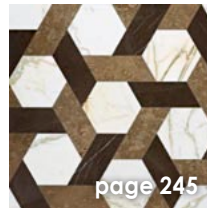

page 245

Istan

Marble: *Azul Marlena,*
Calacatta Vagli, Grafite



page 51

Jalisco Green

Marble: *Bianco Carrara, Olive,*
Verde



page 153

Jalisco Small Black

Marble: *Nero, Nero Ancient*
Glass: *MS Black Iridescent*

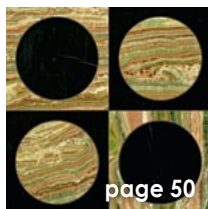

page 50

Jupiter Green

Marble: *Onice Smeraldo, Nero*

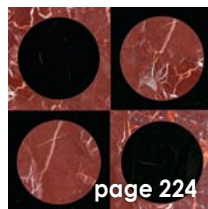

page 224

Jupiter Red

Marble: *Rosso Levanto, Nero*

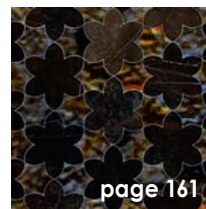

page 161

Kasbah Black

Marble: *Nero*
Glass: *MS Black Iridescent*



page 117

Kasbah Grey

Marble: *Bianco Carrara, Statuario*
Glass: *MS White Iridescent*

Decor Index



Laberiz White

Marble: *Bianco Carrara, Thassos, Statuario*
Glass: *Vis One*

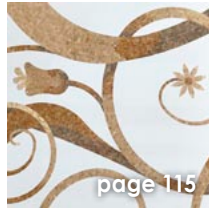

Liasel

Marble: *Dore Royal, Emperador Light, Giallo Royal, Giallo Siena, Gold Byzantine, Thassos*



Losanga Green

Marble: *Olive, Verde*
Glass: *MS White Iridescent*

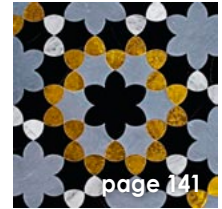

Magreb Black

Marble: *Bardiglio, Nero, Bianco Carrara*
Glass: *Gold*



Magreb Grey

Marble: *Bianco Carrara, Statuario*
Glass: *MS White Iridescent*



Margaritas Pearl

Marble: *Breccia Damascata Rosa, Rosa Pearl*
Glass: *Kaki 3*

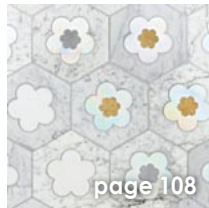

Margaritas White

Marble: *Bianco Americano, Thassos*
Glass: *MS White Iridescent, Kori, Icemir*



Marrakech Black

Marble: *Jaune du Roi, Nero, Nero Ancient,*
Glass: *MS Black Iridescent*



Marrakech Grey

Marble: *Bardiglio, Statuario*
Glass: *MS White Iridescent*



Meandros Black

Marble: *Nero, Nero Ancient, Zebrino*
Glass: *Platinum, Kori*



Meandros Grey

Marble: *Bianco antico, Onice Bianco, Zebrino*
Glass: *Alma*

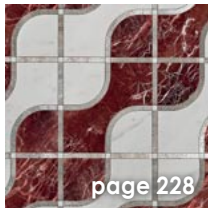

Meandros Red

Marble: *Rosso Levanto, Statuario*
Glass: *Vis One*

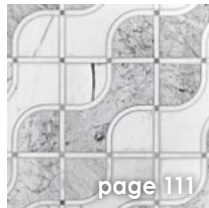

Meandros White

Marble: *Statuario Ancient, Thassos, Bianco Americano*
Glass: *Vis One*



Milele Brown

Marble: *Amarelo Marlana, Nero, Travertino Dorato*
Glass: *MS Beige Iridescent, MS Black Iridescent*

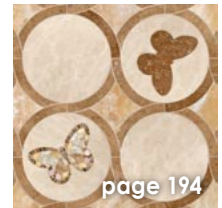

Nocturnia BE

Marble: *Onice Miele, Crema, Noce, Gold Byzantine, Artistic Mosaic*
Glass: *MS White Murano, Kori, Opalis*



Nocturnia BL

Marble: *Nero, Nero Ancient, Artistic Mosaic*
Glass: *Alma, MS Black Iridescent, White Murano,*

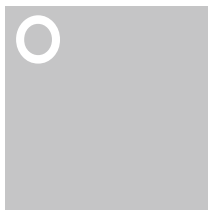

Olson Blue

Marble: *Thassos, Statuario, Bianco Americano*
Glass: *Astrid, Tanzanite*

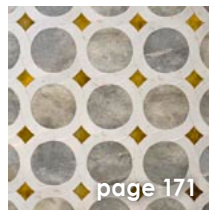

Olson Cappuccino

Marble: *Bianco Sivec, Onice Cappuccino, Travertino Giallo*

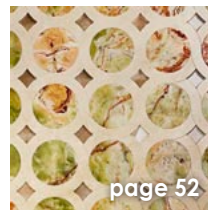

Olson Green

Marble: *Crema, Onice Verde Dark*
Glass: *Vis Two*



Olson Grey

Marble: *Bardiglio, Statuario*
Glass: *MS White Iridescent, Aluminium*



page 68

Olson Irid

Marble: *Bianco Namibia*
Glass: *MS White Iridescent, MS White*

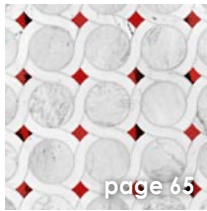

page 65

Olson Ruby

Marble: *Thassos, Statuario, Bianco Americano*
Glass: *Ruby*

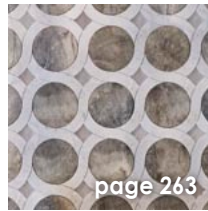

page 263

Olson Taupe

Marble: *Fior di Bosco, Bianco Perlato*
Glass: *Vis One*

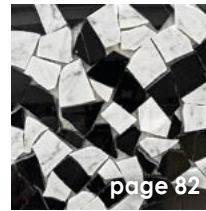

page 82

Palladiana B&W

Marble: *Nero, Bianco Carrara*



page 194

Petalis Crema

Marble: *Crema, Bianco Antico*
Glass: *MS Beige Iridescent, Golden Tide, Kori*



page 103

Plameny Black

Marble: *Bianco Carrara*
Glass: *Black, Vis One, Titanium 2, Titanium 3*



page 103

Plameny White

Marble: *Bianco Carrara*
Glass: *Alma, Vis One, White Titanium 0, Titanium 1, Titanium 2, Titanium 3*



page 179

Primavera

Marble: *Anastasia*
Glass: *Chantal, Vis One, Tharsis*



page 32

Primavera Astrid

Marble: *Azul macauba, Bianco Carrara*
Glass: *Astrid*

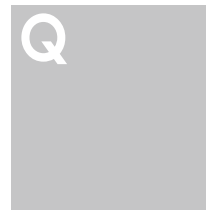

page 72

Qubeck

Marble: *Bianco Carrara, Statuario*
Glass: *Ruby*



page 73

Qubeck Small Gold

Marble: *Bianco Carrara*
Glass: *Gold*

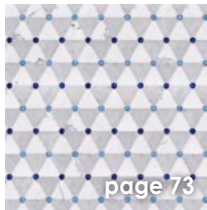

page 73

Qubeck Small Grey

Marble: *Bianco Carrara, Statuario*
Glass: *Astrid 2, Kariba*

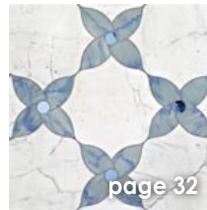

page 32

Randal Azul

Marble: *Azul Macauba, Statuario*
Glass: *Astrid*

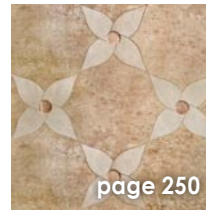

page 250

Randal Nut

Marble: *Giallo Antico, Crema*
Glass: *Kaki 3*



page 245

Salasco Brown

Marble: *Amarelo Marlana, Giallo Antico, Travertino*



page 56

Salasco Green

Marble: *Bianco Americano, Thassos, Verde Luna*

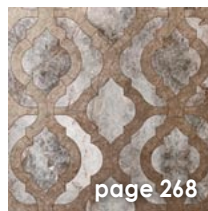

page 268

Salasco Grey

Marble: *Fior di Bosco, Pietra Fossena*



page 133

Scorpions

Marble: *Baikal Rock*
Glass: *Artistic Mosaic*



page 212

Scorpions Brown

Marble: *Briar Wood*
Glass: *Artistic Mosaic*



page 31

Seleris Azul

Marble: *Azul Macauba, Thassos, Bianco Carrara Ancient*

Decor Index



page 264

Seleris Brown

Marble: *Onice Cappuccino, Azul Marlena, Azul Marlena Ancient*



page 249

Seleris Dark

Marble: *Azul Marlena, Emperador, Onice Miele*



page 246

Seleris Pardo

Marble: *Emperador, Giallo Antico, Onice Miele*
Glass: *Vis Two*



page 153

Serpentine Black

Marble: *Nero*
Glass: *MS Black Iridescent*

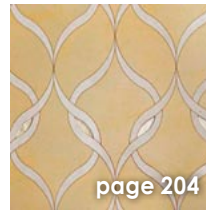

page 204

Serpentine Yellow

Marble: *Quarzite Gialla, Crema*
Glass: *Kori*

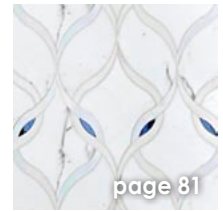

page 81

Serpentine White

Marble: *Statuario, Thassos*
Glass: *MS White Iridescent, Astrid*

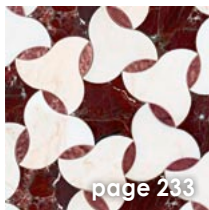

page 233

Sidonel Red

Marble: *Rosa Aurora, Rosso Levanto*
Glass: *Tharsis*

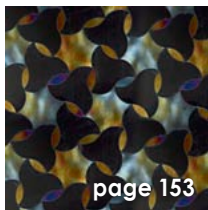

page 153

Sidonel Small Black

Marble: *Nero*
Glass: *MS Black Iridescent*



page 274

Silhouettes

Different Marble

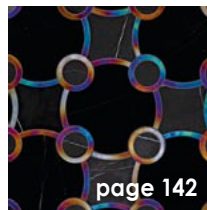

page 142

Sirides Black

Marble: *Nero, Nero Ancient*
Glass: *MS Black Iridescent*

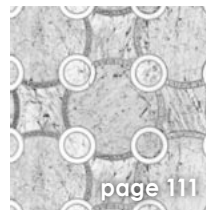

page 111

Sirides White

Marble: *Bianco Americano, Thassos*
Glass: *Aluminium*



page 104

Solangis Quad

Marble: *Bianco Carrara*
Glass: *Talby 2, Selmak 4, Magraner 4, Ruby, Ruby 3*



page 105

Solangis Round

Marble: *Bianco Carrara*
Glass: *Astrid, Athena, Bargel, Lazyl*



page 122

Studs

Marble & Glass



page 153

Tintay Small Black

Marble: *Nero*
Glass: *MS Black Iridescent*



page 54

Tolox Green

Marble: *Bianco Americano, Nero, Verde Luna*
Glass: *MS White Iridescent*

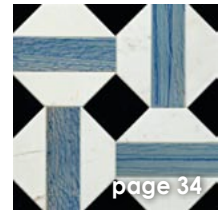

page 34

Toral Blue

Marble: *Azul Macauba, Ebony, Statuario*



page 153

Toral Small Black

Marble: *Nero, Nero Ancient*
Glass: *MS Black Iridescent*



page 271

Trixel

Marble: *Grafite*
Glass: *Talby 2, Carmesim 2, Granada, Aluminium, Seratus, Electra, Astrid, Athena, Bargel*



page 253

Vanart

Marble: *Avellana, Calacatta*



page 70

Vanessa

Marble: *Bianco Americano*
Glass: *Artistic Mosaic*



page 88

Verano

Marble: *Bianco Sivec*
Glass: *Different Colibri*



page 230

Yarmony

Marble: *Bardiglietto, Nero, Rojo, Bianco Americano, Tricot*

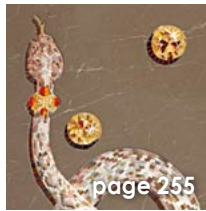

page 255

Yashila

Marble: *Avellana*
Glass: *Artistic Mosaic*

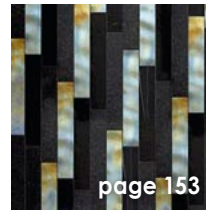

page 153

Zambra

Marble: *Galaxy Black, Nero*
Glass: *MS Black Iridescent*

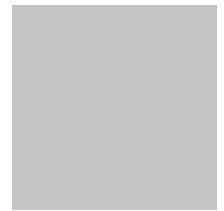

Marble Mosaic

Bianco Namibia

Page 62

Bardiglio Imperiale

Page 126

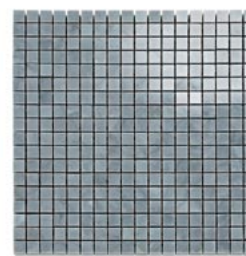
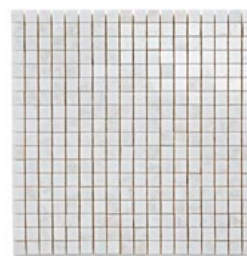
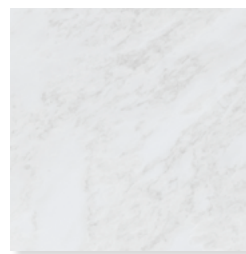

with Colibri Vis One

with Colibri Vis One



with Colibri Carmesim 2

with Colibri Vis One

*L'attuale Collezione di Marmi è composta da marmo e vetro: due tipologie di materiali con proprietà e caratteristiche differenti, ma pur sempre compatibili fra loro e la cui posa può essere effettuata con i più diffusi adesivi e sigillanti disponibili in commercio. La scelta dei materiali di posa, pur dipendente dalla destinazione d'uso del manufatto finito, non potrà cadere su prodotti a base cementizia nel caso di composizioni con **Icemir**.*

*The current Marble Collection is made up of marble and glass: two types of materials with different properties and characteristics, but still compatible and whose installation can be done with the most common adhesives and sealing products available in the market. The choice of the installing materials depends on the final destination of the finished product: compositions which include **Icemir** must be installed using non cement-based products only.*

Bardiglio Orientale

Page 124

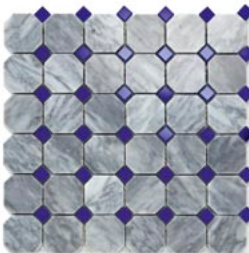
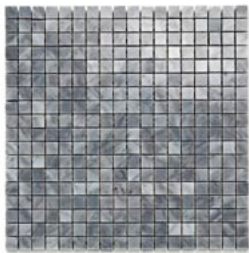

with Colibri Tanzanite

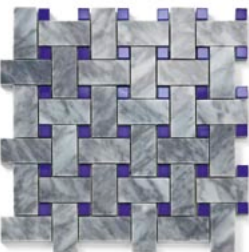

with Colibri Tanzanite

Bianco Perlato

Page 177



with Colibri Vis Two



with Marble Rosa Pearl

Onice Bianco

Page 181



with Colibri Fentas



with Murano Smalto Beige Iridescent

Onice Spider White

Page 183

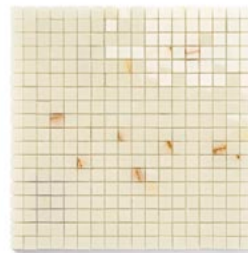
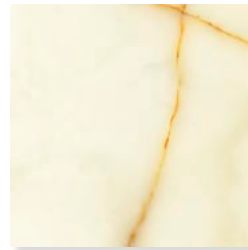

with Colibri Gold

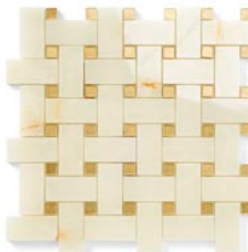

with Colibri Kori

30,5 x 30,5 cm
12" x 12"

Tesserae 15x15
29,6 x 29,6 cm
11 5/8" x 11 5/8"

Exagon
29,8 x 26,1 cm
11 3/4" x 10 1/4"

Octagons
29,8 x 29,8 cm
11 3/4" x 11 3/4"

Basket Weave
30,5 x 30,5 cm
12" x 12"

SICIS

Zebrino

Page 187



Onice Crema

Page 190



Onice Miele

Page 197



Onice Golden

Page 201

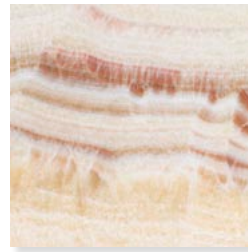

Quarzite Gialla

Page 205



with Colibri Grey Flannel



with Colibri Golden Tide



with Colibri Gold



with Colibri Kori

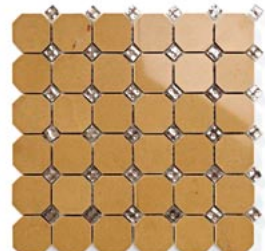

with Colibri Platinum Tide



with Colibri Alma



with Murano Smalto Beige Iridescent



with Colibri Gold



with Marble Rojo Ancient



with Colibri Kori

Travertino Giallo

Page 210



with Colibri Gold



with Colibri Vis Two

Briar Wood

Page 213

Thickness: minimum 2 cm - 3/4"

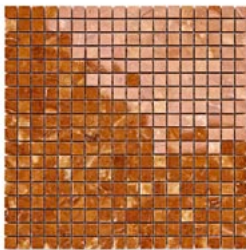

with Colibri Golden Tide



with Colibri Copper

Onice Rosa

Page 219

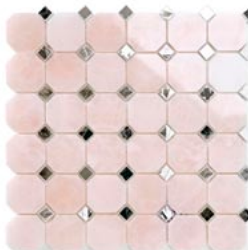

with Colibri Alma

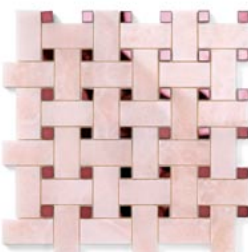

with Colibri Violet

Breccia Damascata Rosa

Page 221

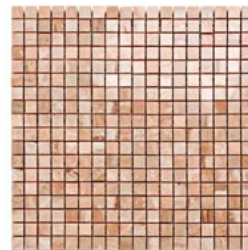

with Colibri Fentas



with Marble Rosa Pearl

30,5 x 30,5 cm
12" x 12"

Tesserae 15x15
29,6 x 29,6 cm
11 5/8" x 11 5/8"

Exagon
29,8 x 26,1 cm
11 3/4" x 10 1/4"

Octagons
29,8 x 29,8 cm
11 3/4" x 11 3/4"

Basket Weave
30,5 x 30,5 cm
12" x 12"

SICIS

Tricot

Page 226

Rosso Levanto

Page 229

Travertino Dorato

Page 242

Breccia Oniciata

Page 257

Giallo Antico

Page 251

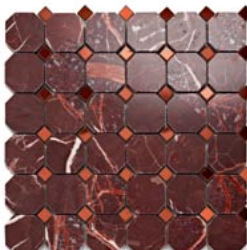
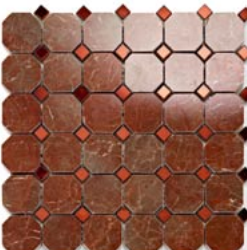
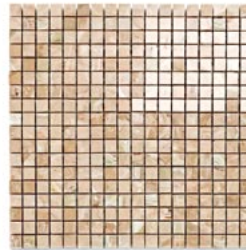
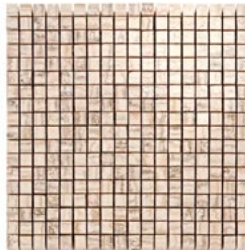
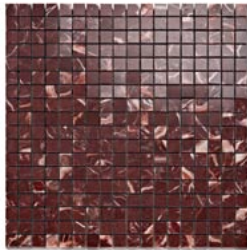
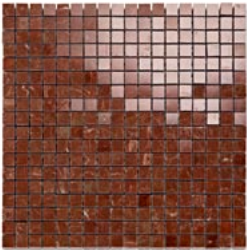
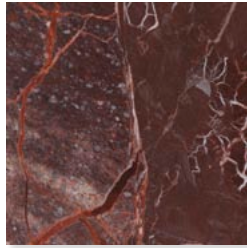
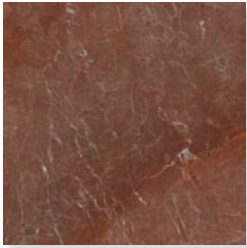

with Colibri Copper

with Colibri Copper

with Colibri Platinum Tide

with Colibri Vis Two

with Colibri Vis Two



with Colibri Vis Two

with Marble Rojo Ancient

with Murano Smalto Beige Iridescent

with Colibri Vis Two

with Colibri Vis Two

Avellana

Page 252

Thickness: minimum 2 cm - 3/4"



Onice Verde Dark

Page 53



Verde Giada

Page 45

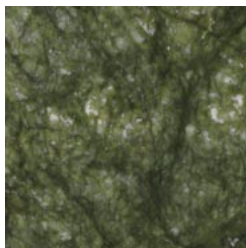

Verde Lapponia

Page 49

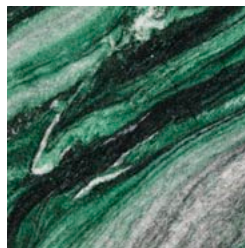

30,5 x 30,5 cm
12" x 12"

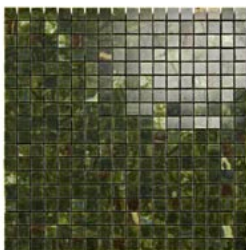
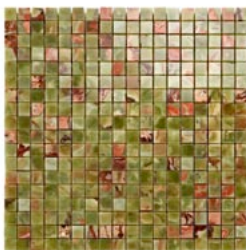
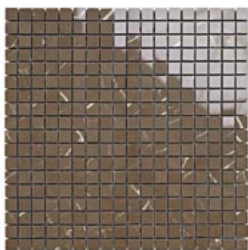

Tesserae 15x15
29,6 x 29,6 cm
11 5/8" x 11 5/8"



Exagon
29,8 x 26,1 cm
11 3/4" x 10 1/4"

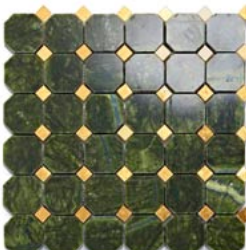

Octagons
29,8 x 29,8 cm
11 3/4" x 11 3/4"

with Colibrì Alma

with Colibrì Gold

with Colibrì Gold

with Colibrì Platinum



Basket Weave
30,5 x 30,5 cm
12" x 12"

with Colibrì Kori

with Marble Rosa Pearl

with Colibrì Vis One

with Colibrì Vis One

SICIS

Sodalite Blue

Page 29

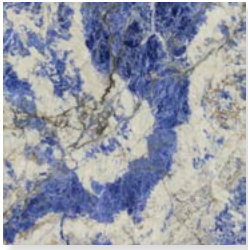

with Colibri Platinum



with Colibri Tanzanite

Onice Cappuccino

Page 265



with Colibri Platinum



with Colibri Platinum

Fior di Bosco

Page 260

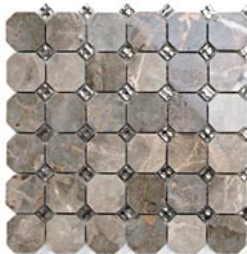

with Colibri Platinum Tide



with Colibri Fentas

Pietra Fossena

Page 269

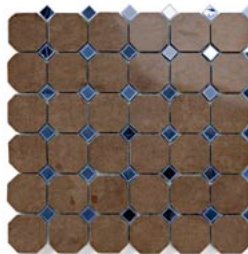

with Colibri Astrid



with Colibri Fentas

Grafite

Page 272



with Colibri Vis One



with Colibri Copper

Baikal Rock

Page 135

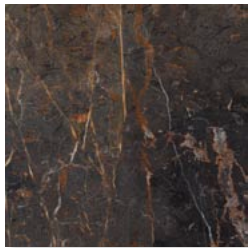

Portoro Extra

Page 138

Thickness: minimum 2 cm - 3/4"

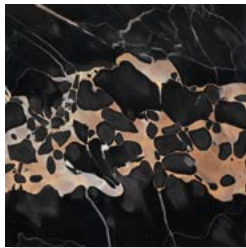

Noir Saint Laurent

Page 162



Ebony Black

Page 146

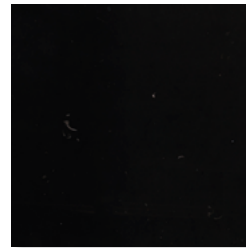

30,5 x 30,5 cm
12" x 12"

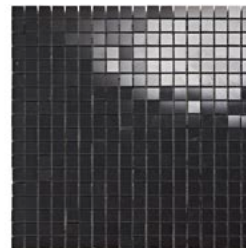
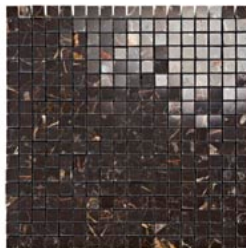
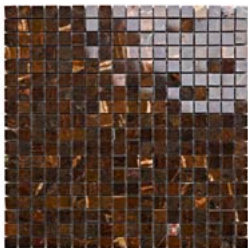

Tesserae 15x15
29,6 x 29,6 cm
11 5/8" x 11 5/8"



Exagon
29,8 x 26,1 cm
11 3/4" x 10 1/4"

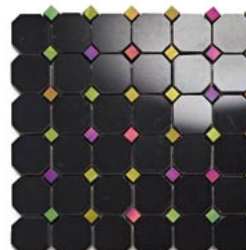
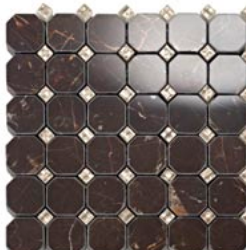
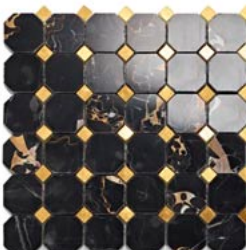
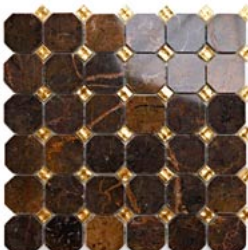

Octagons
29,8 x 29,8 cm
11 3/4" x 11 3/4"

with Colibri Golden Tide

with Colibri Gold

with Colibri Platinum Tide

with MS Black Iridescent & Orchis

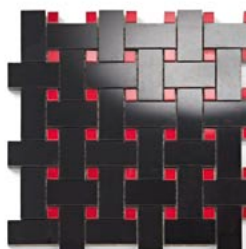

Basket Weave
30,5 x 30,5 cm
12" x 12"

with Colibri Copper

with Colibri Vis Two

with Colibri Vis Two

with Colibri Carmesim 2

SICIS

Technical Data

SICIS

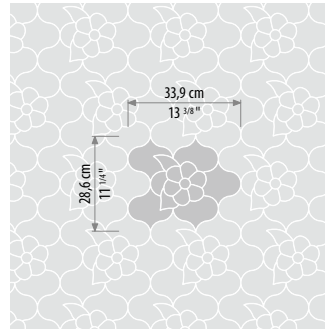

Aguamiel

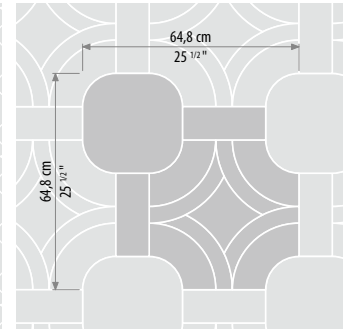

Algar

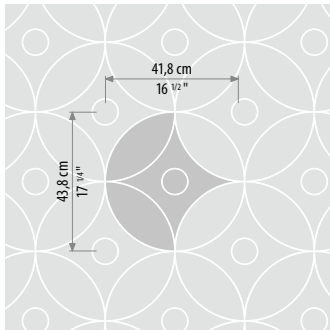

Alia

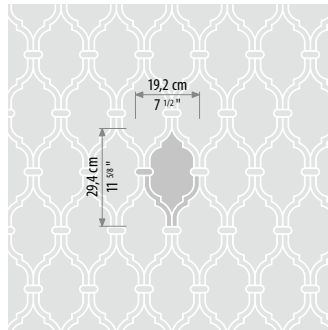

Aloina

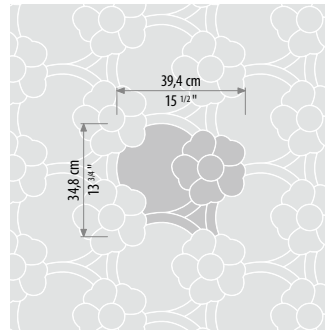

Amapola

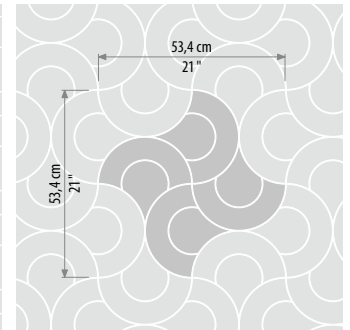

Amidele

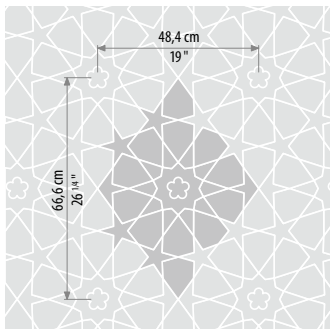

Andalusì

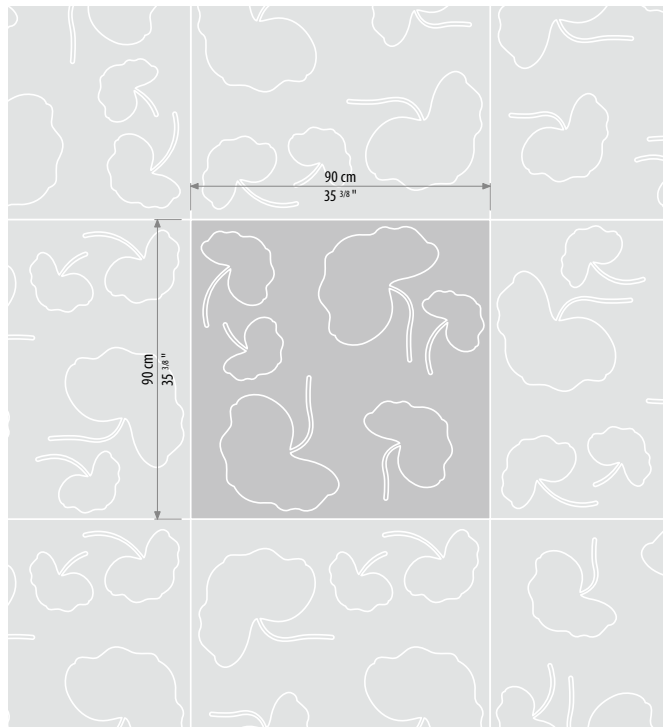

Andel

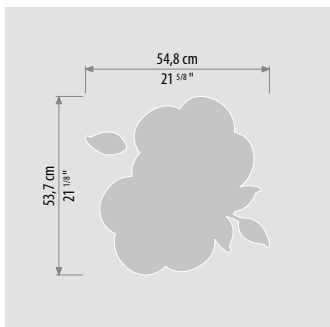

Anemil

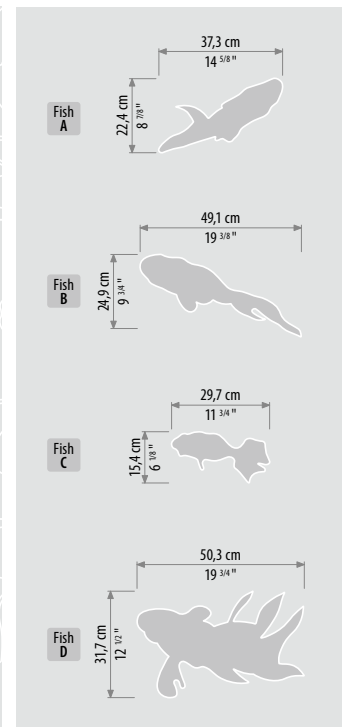

Aquarium

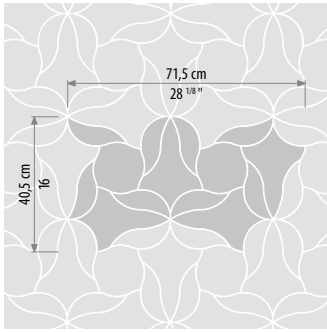

Azahar

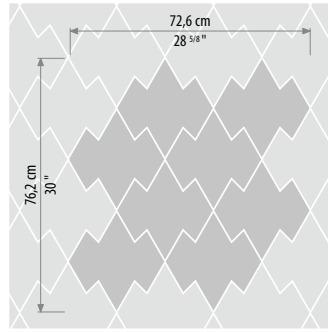

Azetek

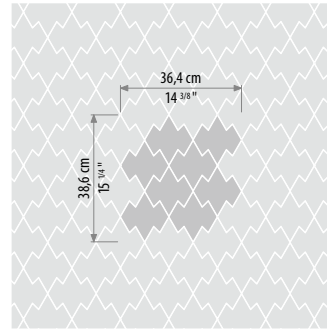

Azetek Small

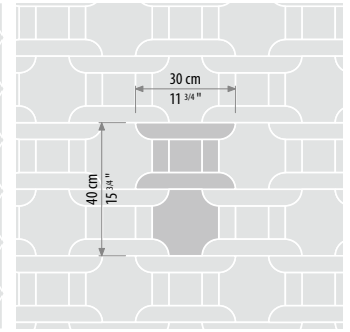

Cadeia

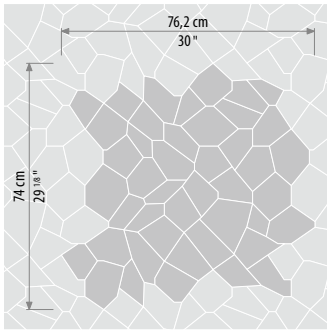

Caleidos

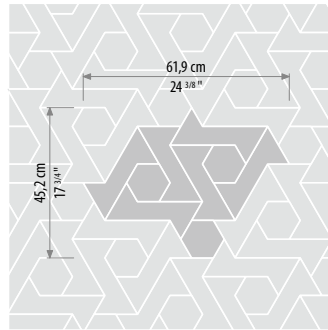

Celosin

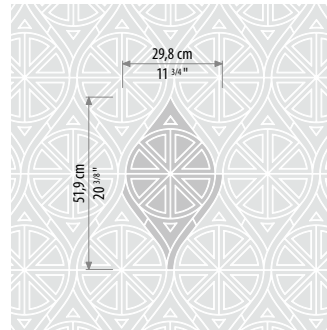

Cetrix

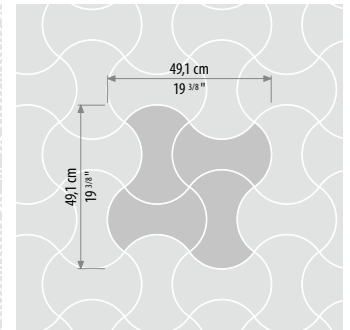

Clessidra

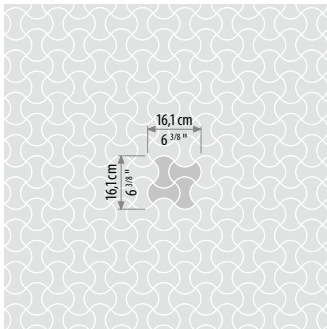

Clessidra Small

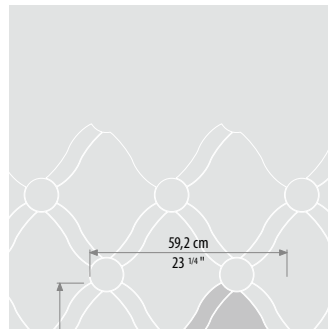

Dalisa

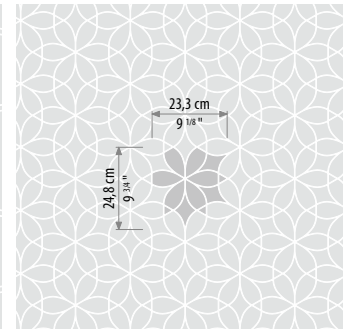

Delicatissimum

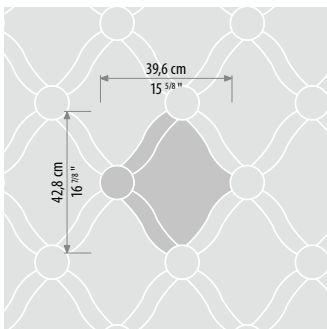

Dralis

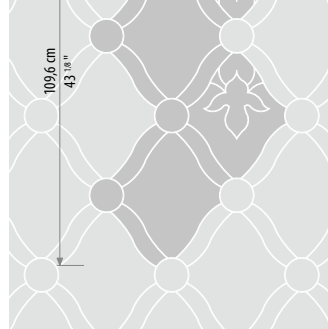

Dralis Flor

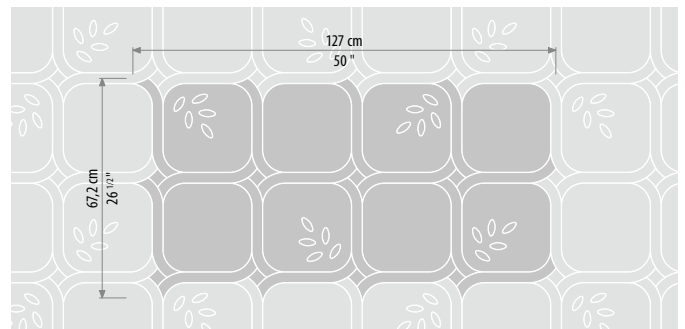

Elecos

Technical Data

SICIS

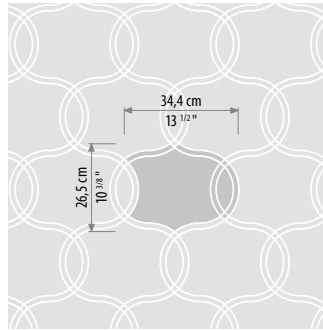

Enlaxo

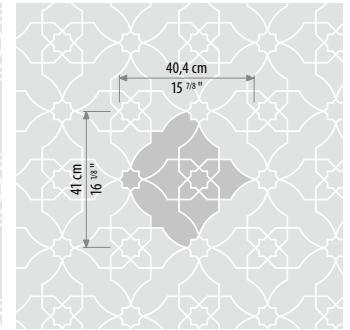

Feras

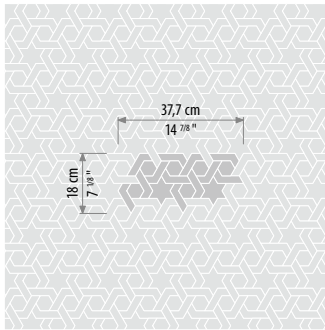

Firmamentus

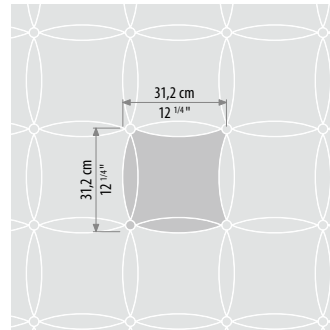

Girona

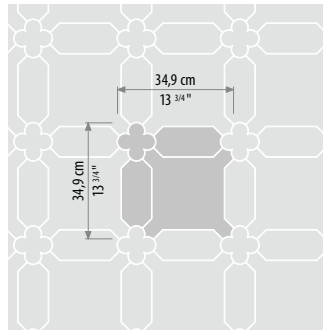

Iberis

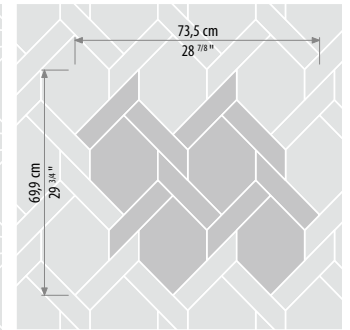

Inxert

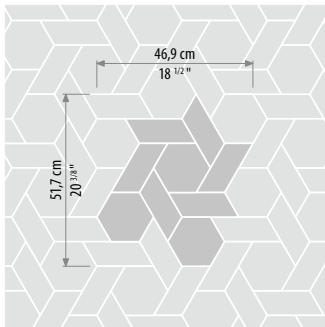

Istan

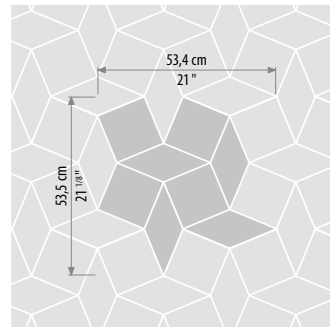

Jalisco

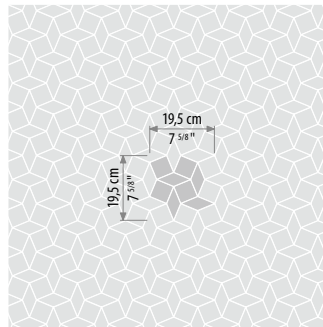

Jalisco Small

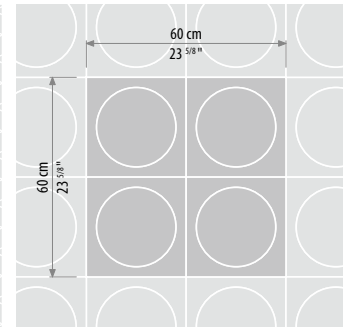

Jupiter

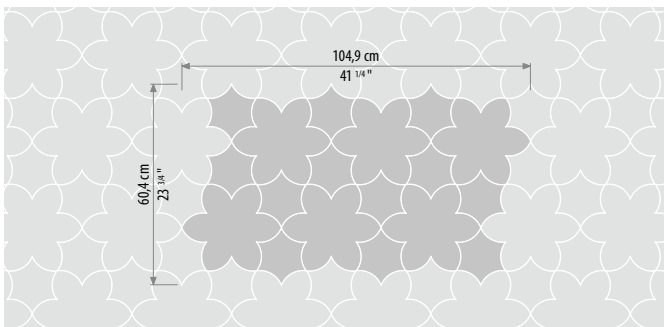

Kasbah

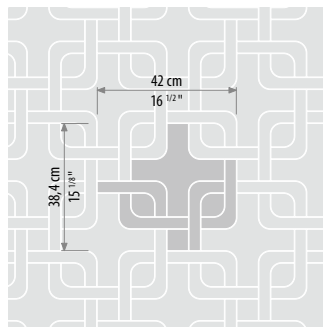

Laberiz

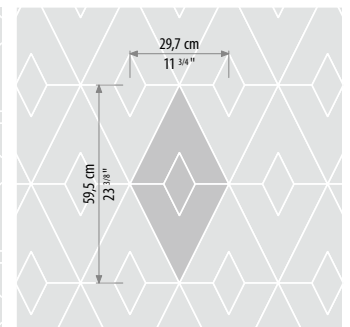

Losanga

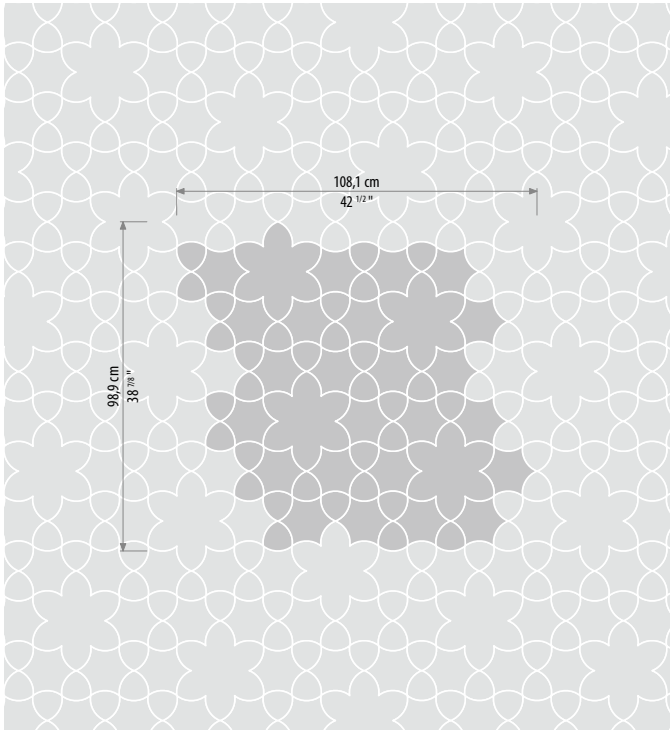

Magreb

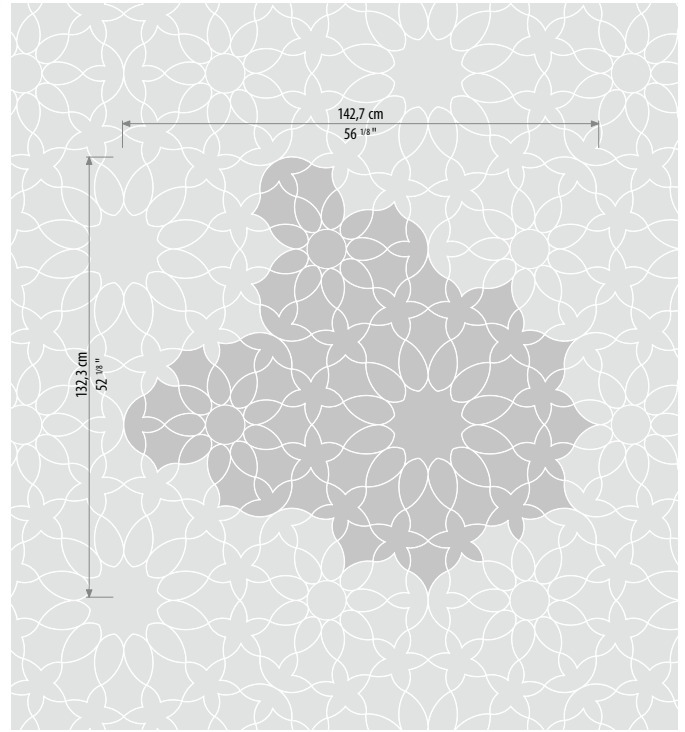

Marrakech

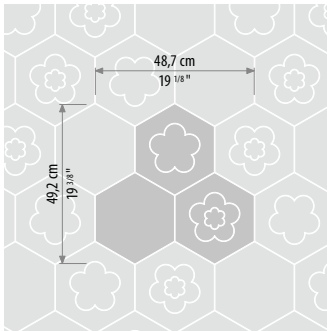

Margaritas

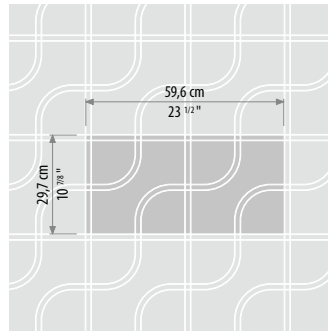

Meandros

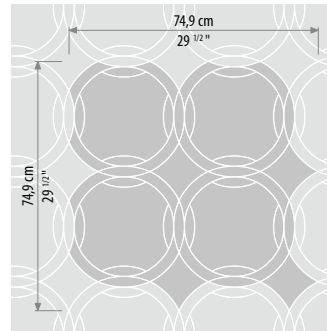

Milele

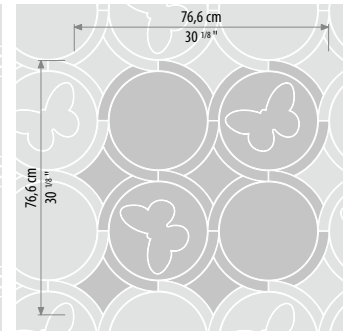

Nocturnia

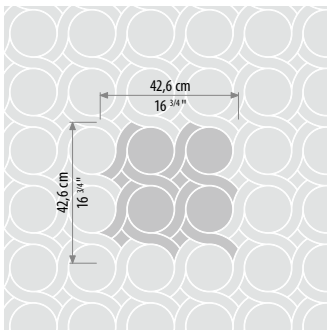

Olson

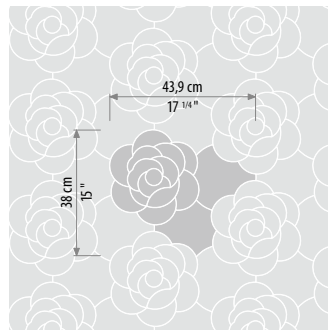

Petalis

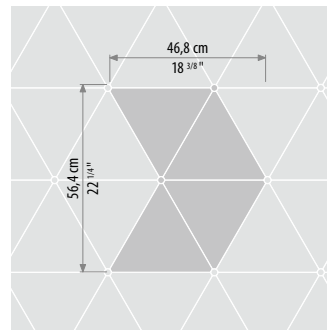

Qubeck

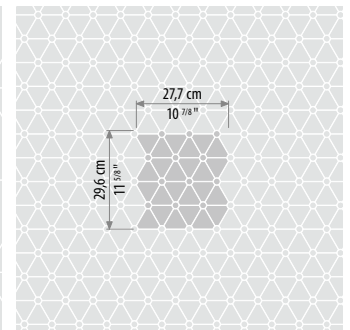

Qubeck Small

Technical Data

SICIS

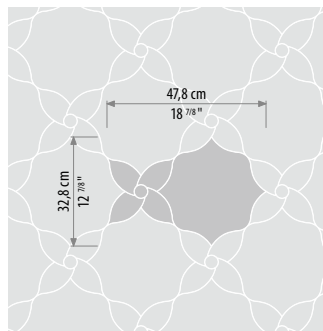

Randal

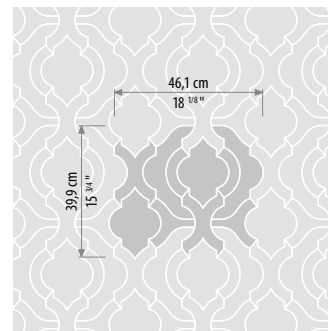

Salasco

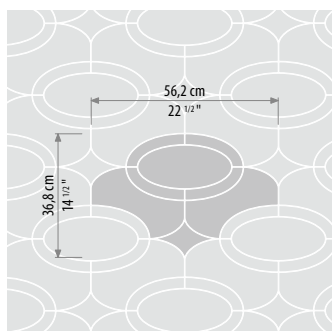

Seleris

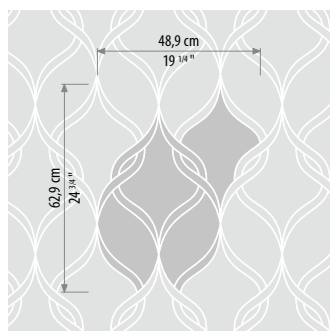

Serpentine

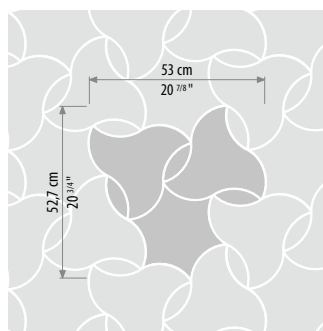

Sidonel

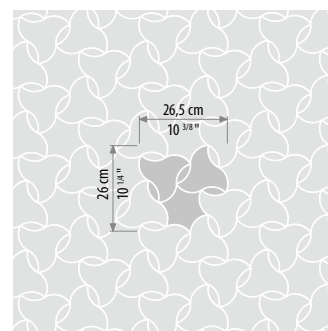

Sidonel Small

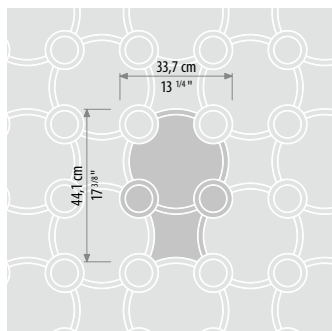

Sirides

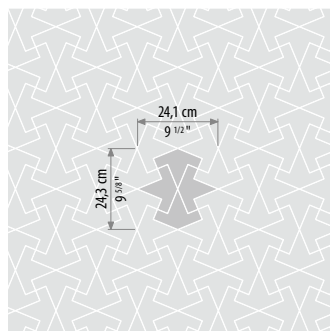

Tintay Small

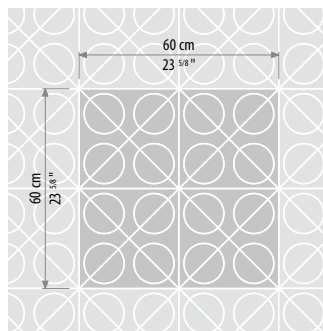

Tolox

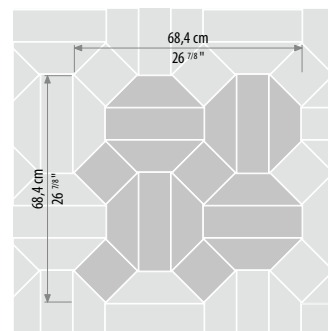

Toral

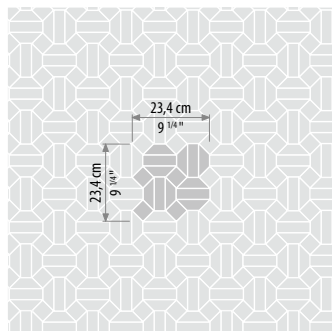

Toral Small

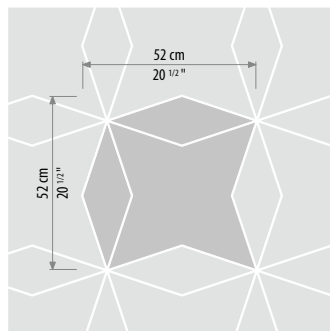

Vanart

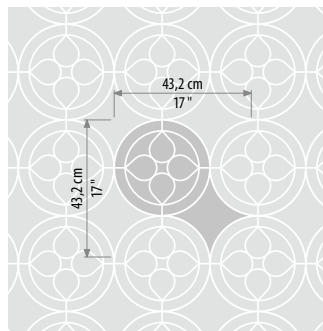

Yarmony

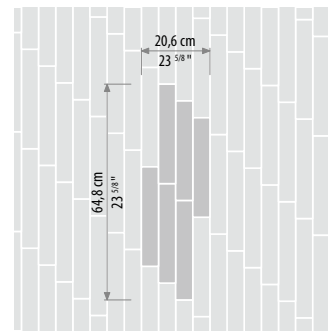

Zambra

Borders

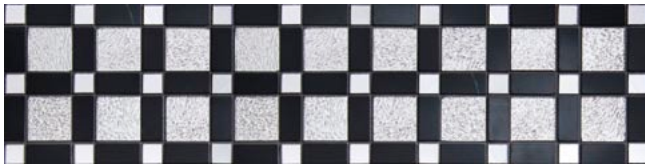

Viorder BW

h 11,5 cm · h 4 1/2"



Enges BLX

h 9,8 cm · h 3 3/8"



Clessum BLX

h 9,8 cm · h 3 3/8"



Gradium BLX

h 9,8 cm · h 3 3/8"

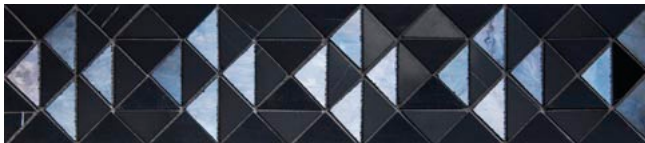

Oderes BLX

h 9,8 cm · h 3 3/8"



Trapex BLX

h 9,8 cm · h 3 3/8"

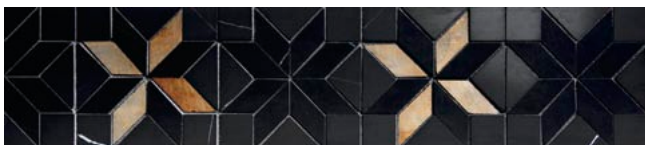

Quirder BLX

h 9,8 cm · h 3 3/8"

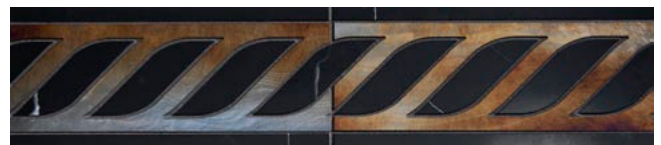

Funis BLX

h 9,8 cm · h 3 3/8"

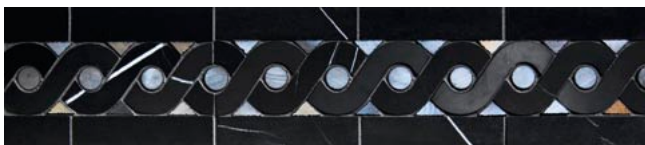

Niuram BLX

h 9,8 cm · h 3 3/8"



Excelsus BLX

h 9,8 cm · h 3 3/8"



Frisex BLX

h 9,8 cm · h 3 3/8"



Legius BL

h 9,8 cm · h 3 3/8"

NOTIFICHE LEGALI

Il presente catalogo è fornito gratuitamente, ma è e rimane proprietà Sicis e non può quindi essere oggetto di vendita. Nessuna parte del catalogo può essere riprodotta senza autorizzazione scritta di Sicis. Non esistono altre licenze, né implicite né espresse, per riprodurre una qualsiasi parte del presente catalogo o di qualsiasi disegno di mosaico in esso contenuto, al di fuori della licenza scritta e firmata da Sicis. Il contenuto del presente catalogo è protetto dalle leggi sul Copyright, comprese le foto e i disegni dei mosaici.

I colori non possono essere riprodotti in maniera esatta, essendo le variazioni di colore una caratteristica intrinseca del prodotto stesso. I campioni mostrati nel catalogo sono da ritenersi puramente indicativi.

SICIS è un marchio registrato da Sicis S.r.l.

Sicis si riserva tutti i diritti del presente catalogo e dei disegni dei mosaici illustrati, compreso il diritto di adire le vie legali contro le infrazioni al Copyright.

LEGAL NOTICES

This catalogue has been provided to you free of charge, but it is and remains the property of Sicis and cannot be sold. You may not reproduce any part of this catalogue without the written authorization of Sicis. There are no licenses, either implied or expressed, to reproduce any part of this catalogue or any of the mosaic designs unless the license is in writing and signed by Sicis. Copyright Laws protect the content of this catalogue, including the photographs and the Sicis mosaic designs.

The color variations cannot be reproduced exactly since they are an intrinsic feature of the product. The sample shown in this catalogue must be considered merely indicative.

SICIS is trademark of Sicis S.r.l.

Sicis explicitly reserves all rights to this catalogue and the mosaic designs therein, including the right to bring legal action for Copyright infringement.

© 2012, 2013, 2014, 2015 Sicis s.r.l. Ravenna, Italy
Printed in Italy · February 2015

SICIS

Showroom Milano 20121 · Via Fatebenefratelli, 8
Ph. +39 02 87 60 99 · Fax +39 02 72 09 68 53

Factory Ravenna (Italy) · Fax +39 0544 46 98 11

SICIS FRANCE

Showroom Paris 75008 · 41, Rue François 1^{er}
Ph. +33 (0)1 49 52 89 89 · Fax +33 (0)1 49 52 89 90

SICIS ME

Showroom and Offices Dubai, (UAE) · Villa 12 · P. O. Box 23592
Corner of Umm Al Sheif & Jumeirah Beach Road
Ph. +971 (0)4 395 3835 · Fax +971 (0)4 395 3860

SICIS INDIA

Showroom New Delhi 110024 D-5 Defence Colony, First Floor
Ph. +91 (0)11 46 11 48 00 · Fax +91 (0)11 46 11 48 44

SICIS TURKEY

Sicis Istanbul-European Showroom
Maçka Cad. No:1 Nişantaşı
Ph. +90 212 240 25 96 · Fax +90 212 240 25 64

SICIS JAPAN

Showroom Tokyo · Mille Roches' Building B1
5-3-5 Minamiaoyama, Minato-Ku
Ph. +81 (0)3 3406 1040 · Fax +81 (0)3 3406 1042

SICIS HONG KONG

Showroom Hong Kong · Queen's Cube
235/237 Queen's Road East, Wan Chai
Ph. +(852) 2832 2830 · Fax +(852) 2833 9009

SICIS NORTH AMERICA

Showroom and Offices New York 10013 · 470 Broome Street
Ph. +1 212 965 4100 · Fax +1 212 343 7065
USA Toll free number 877 839 8900

www.sicis.com · info@sicis.com