



PLAY  
ONE

Temi d'ambiente  
Interior compositions



Temi d'ambiente  
Interior compositions



Playone	p. 04	
Temi d'ambiente · Interior compositions	p. 06	
• <b>La Casa dell'Esploratore · The House of the Explorer</b>		<i>Interior Design</i>
Ingresso · Entrance	p. 13	p. 100
Soggiorno 1 · Living room 1	p. 15	p. 101
Soggiorno 2 · Living room 2	p. 16	p. 102
Cucina · Kitchen	p. 19	p. 103
Bagno · Bathroom	p. 22	p. 104
Vano scala · Stairwell	p. 25	p. 105
Risto Bar · Restaurant Café	p. 28	p. 106
• <b>La Casa della Scrittrice · The House of the Writer</b>		<i>Interior Design</i>
Soggiorno 1 · Living room 1	p. 34	p. 107
Soggiorno 2 · Living room 2	p. 36	p. 108
Soggiorno 3 · Living room 3	p. 39	p. 109
Ingresso · Entrance	p. 43	p. 110
Cucina 1 · Kitchen 1	p. 45	p. 111
Bagno · Bathroom	p. 46	p. 112
Patio · Patio	p. 50	p. 113
Cucina 2 · Kitchen 2	p. 53	p. 114
• <b>La Casa del Navigatore · The House of the Seafarer</b>		<i>Interior Design</i>
Ingresso · Entrance	p. 59	p. 115
Cucina 1 · Kitchen 1	p. 60	p. 116
Zoom cucina · Zoom kitchen	p. 62	p. 116
Zona notte 1 · Bedroom 1	p. 65	p. 117
Zona notte 2 · Bedroom 2	p. 67	p. 118
Bagno · Bathroom	p. 71	p. 119
Soggiorno · Living room	p. 72	p. 120
Ristorante · Restaurant	p. 77	p. 121
• <b>La Casa del Musicista · The House of the Musician</b>		<i>Interior Design</i>
Ingresso · Entrance	p. 83	p. 122
Stanze · Rooms	p. 85	p. 123
Soggiorno · Living room	p. 88	p. 124
Zoom soggiorno · Zoom living room	p. 90	p. 124
Zona notte · Bedroom	p. 93	p. 125
Ristorante · Restaurant	p. 94	p. 126
Concrete + Krea	p. 98	
Interior Design	p. 102	
Playone: visione sinottica · Playone: synoptic vision	p. 128	
Schemi di posa · Layout	p. 130	
Formati e colori · Shapes and colours	p. 134	
Note tecniche · Technical notes	p. 138	



# Playone

PLAY  
ONE

Playone è un articolato sistema di formati, colori e superfici prodotti da Gigacer in gres fine porcellanato nello spessore di 4,8 mm.

Playone è un invito a progettare, ad abbinare le prestigiose lastre 120x120 con i piccoli e inediti formati quali il 9x9, l'ottagono, il rombo, i mosaici tondi o quadrati, i rettangoli, le matite.\*

Grazie a questo strutturato sistema si possono riprodurre con facilità, anche attraverso l'uso del rombo in più colori, la bellezza e l'efficacia stilistica delle pavimentazioni prospettive degli edifici storici. Inoltre i formati disponibili mettono a disposizione del progetto decise geometrie e calibrate bordure, per pavimenti e rivestimenti contraddistinti dalla connotazione classica.

L'industria e la tecnologia innovativa di Gigacer\*\* sono al servizio del progetto di interior, come emerge con sorprendente attualità da questo sistema ceramico.

La moderna materia Playone si riappropria del ruolo decorativo e strutturale della ceramica in ambito architettonico attraverso il racconto di trenta ambienti progettati da designer e interior decorator. Modernità per Gigacer significa qualità, sostenibilità e durabilità.

Il ridotto spessore, la leggerezza, la facilità di movimentazione e lavorazione, la resistenza e la qualità rendono Playone un materiale perfetto anche nell'ambito delle ristrutturazioni.

Playone is a complex system of shapes and sizes, colors and surfaces produced by Gigacer in fine porcelain stoneware with a thickness of 4.8 mm.

Playone is an invitation to design, to juxtapose the prominent 120x120 slabs with smaller and unconventional sizes such as 9x9, octagonal, diamond, rounded or square mosaics, rectangular, liners.

Thanks to this structured system, it is easy to recreate the beauty and impact of the geometric floors found in historic buildings through the combination of the diamond shaped tiles in multiple colors. Moreover the variety of sizes and shapes available allow to create a variety of geometrical effects and borders, for floor and wall coverings with a classical connotation.

Gigacer's\*\* innovative technology and production are at the service of any interior design project as demonstrated by this unique and relevant ceramic system.

Playone's modern materials reappropriate the role of structural and decorative ceramics in architecture through the compositions of thirty rooms created by interior decorators and designers. For Gigacer, modernity means quality, sustainability and durability.

Its reduced thickness, lightweight design, ease of transport and installation, durability and quality make Playone the perfect material for renovations as well.

\* La visione completa e sinottica del sistema Playone si trova a pagina 128

\*\* La tecnologia Gigacer è spiegata a pagina 138

\* For the overall vision and the synoptics of the Playone system, go to page 128

\*\* Gigacer technology is explained on page 138



# Temi d'ambiente

## Interior compositions

PLAY  
ONE

Questo libro accompagna il lettore alla scoperta di alcune dimore piene di luce, personalizzate da un sapiente utilizzo della ceramica a pavimentazione e a rivestimento.

*This book takes the reader on a discovery of homes full of light, customized with the adept use of ceramic floor and wall coverings.*

In "Temi d'ambiente Playone" la narrazione si incentra sulla storia di quattro personaggi, raccontata attraverso suggestivi progetti d'ambiente caratterizzati da forti scelte cromatiche. Il colore delle pavimentazioni e dei rivestimenti connota lo stile di vita dei personaggi che vi abitano.

Osservando la versatile gamma cromatica di Playone appare evidente la solidità dei colori naturali delle terre, la raffinatezza dei bianchi e neri, la luminosità dei blu con i bianchi, la classicità del rosso e verde, stili diversi per diversi caratteri.

Per queste semplici ragioni:

ai toni della terra è abbinata la casa dell'Esploratore,

ai toni del nero e del bianco è abbinata la casa della Scrittrice,

ai toni dei blu e del bianco ice è abbinata la casa del Navigatore,

ai toni del rosso e del verde è abbinata la casa del Musicista classico.

Con Playone Gigacer affronta il tema della classicità delle pavimentazioni utilizzando tecnologie di ultima generazione.

Ogni progetto d'ambiente è supportato da una scheda tecnica -interior design- che permette di risalire a tutti gli elementi della pavimentazione e del rivestimento.

In "Playone's Interior Compositions", the narrative recounts the stories of four characters by means of evocative interior projects characterized by strong color schemes. The color schemes of the floor and wall coverings reflect the lifestyles of the characters who inhabit these spaces.

By examining Playone's versatile color range, the strength of the earthtones, the refinement of the blacks and whites, the brightness of the blues with whites, and the classic reds and greens, are evident - different styles representing different characters.

For these simple reasons:

the Explorer's home is associated with earthtones,

the Writer's home is associated with shades of black and white,

the Seafarer's home is associated with shades of blue and ice white,

the Classical musician's home is associated with shades of red and green.

Using the latest technology, tackle the question of traditional flooring with Playone Gigacer.

Each interior proposal is supported by a technical module - interior design - allowing you to examine all the elements of the wall and floor coverings.

# Temi d'ambiente

Interior compositions

PLAY  
ONE

## La Casa dell'Esploratore

The House of the Explorer



KREA GROUND

CONCRETE ROPE

CONCRETE BEIGE

CONCRETE BROWN

KREA ORANGE

CONCRETE WHITE

KREA NUT

La solidità dei colori naturali della terra è ciò che contraddistingue la casa dell'esploratore.

The strength of earthtones distinguishes the home of the explorer.



Un altro viaggio è giunto al termine:  
ancora un'avventura, una scoperta, un ricco bagaglio  
di ricordi e di nuove conoscenze.  
Immagini, profumi, volti di persone, ricordi di luoghi  
e di sensazioni nuove da portare con sé.

Il ritorno a casa: ritrovare ancora una volta  
il proprio ambiente, così familiare e denso di ricordi  
di altri viaggi e di altre scoperte.  
Colori, superfici, arredi, aromi che dialogano tra loro  
in calda armonia.  
La casa del ritorno, il riposo del corpo e della mente,  
per progettare, in fondo, ancora una nuova avventura.

Yet another journey has come  
to an end. An adventure, a discovery, a  
wealth of memories and knowledge.  
Images, fragrances, faces, memories  
of places and new sensations  
to carry with you.



The return home: once again in  
your element, so familiar and so full  
of memories of past voyages and  
discoveries.  
Colors, surfaces, furniture, aromas  
interacting with each other  
in a symphony of warmth.  
Coming back home, the body and  
mind becalmed, to plan, after all,  
yet another adventure.

**Ingresso**  
Entrance

FLOOR

Beige - White  
30x30 cm

Nut  
Plate 9x30 cm  
Small 9x9 cm

• Interior Design p. 100



PLAY  
ONE





**Soggiorno 1**  
Living room 1

**FLOOR**

**Rope - White**  
120x120 cm

**Beige**  
Stripes Mosaic 30x60 cm  
30x60 cm  
Mosaic 30x30 cm  
Action mosaic 30x30 cm  
30x30 cm

- **Interior Design** p. 101







**Soggiorno 2**  
Living room 2

- FLOOR
- Brown · Graphite**  
Octagon 30x30 cm  
10x60 cm
- Brown**  
15x60 cm  
Plate 9x30 cm
- Rope · Red**  
Button 3x3 cm

• Interior Design p. 102



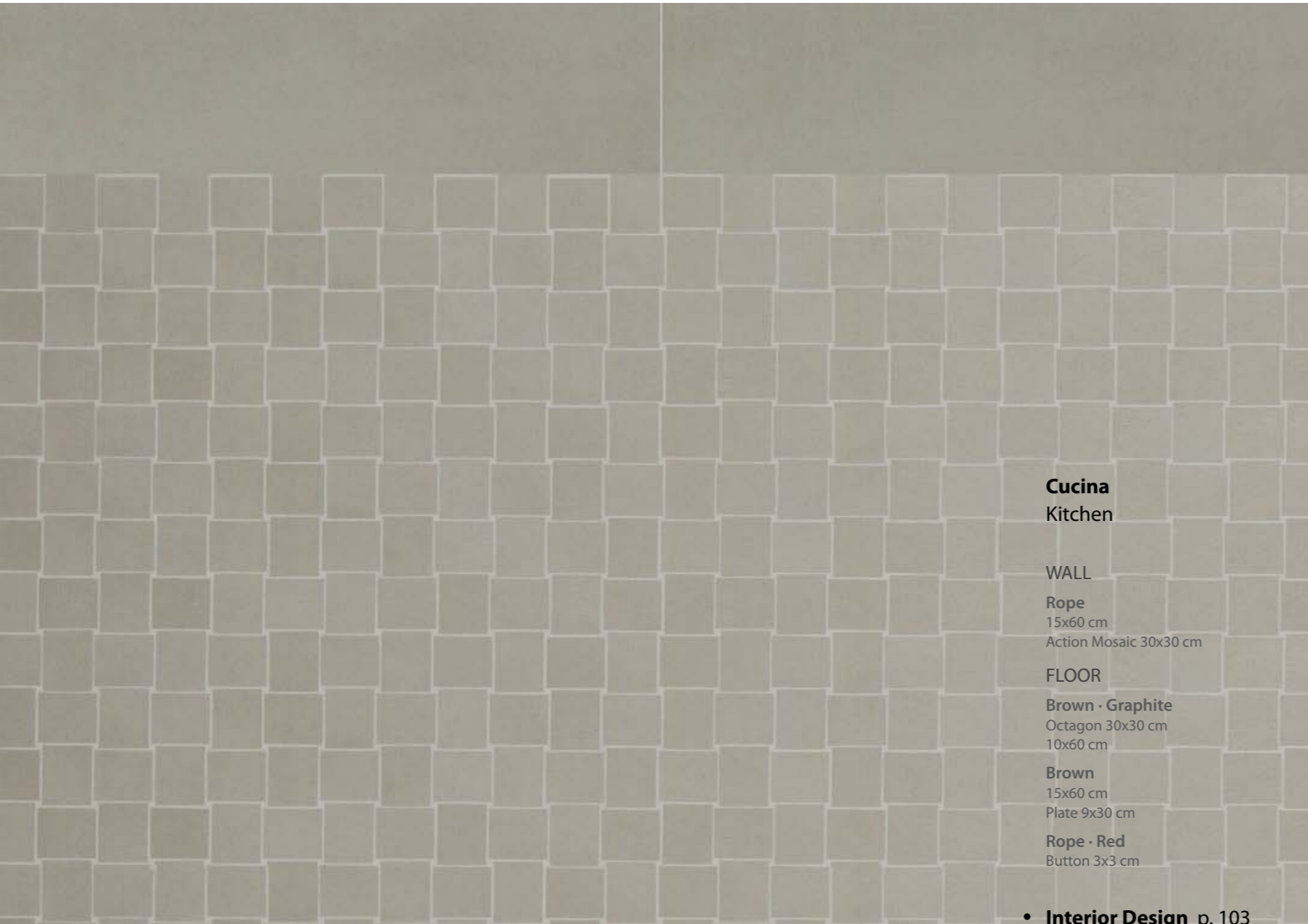

**Cucina**  
Kitchen

WALL  
Rope  
15x60 cm  
Action Mosaic 30x30 cm

FLOOR  
Brown · Graphite  
Octagon 30x30 cm  
10x60 cm

Brown  
15x60 cm  
Plate 9x30 cm

Rope · Red  
Button 3x3 cm

• Interior Design p. 103







Il viaggio non soltanto allarga la mente: le dà forma.  
(Bruce Chatwin, *Anatomia dell'irrequietezza*)

The journey not only broadens the mind: but it gives it shape.  
(Bruce Chatwin, *Anatomy of restlessness*)







**Bagno**  
Bathroom

**WALL**

**Orange**  
120x120 cm  
Stripes Mosaic 15x120 cm [3 stripes 1.5x120 cm]

**FLOOR**

**Orange · Beige · White**  
Diamond 18x18 cm

- **Interior Design** p. 104





**Vano scala**  
Stairwell

**FLOOR**

**Orange · Beige · White**  
Diamond 18x18 cm

**Orange**  
30x30 cm

**White**  
Stripes Mosaic 15x120 cm  
[1 stripe 1.5x120 cm]

- **Interior Design** p. 105





Le nostre valigie erano di nuovo amucchiate sul marciapiede; avevamo molta strada da fare. Ma non importava, la strada è la vita. *(Jack Kerouac)*

Our suitcases were piled on the sidewalk again, we had a long way to go. But it didn't matter, the road is life. *(Jack Kerouac)*

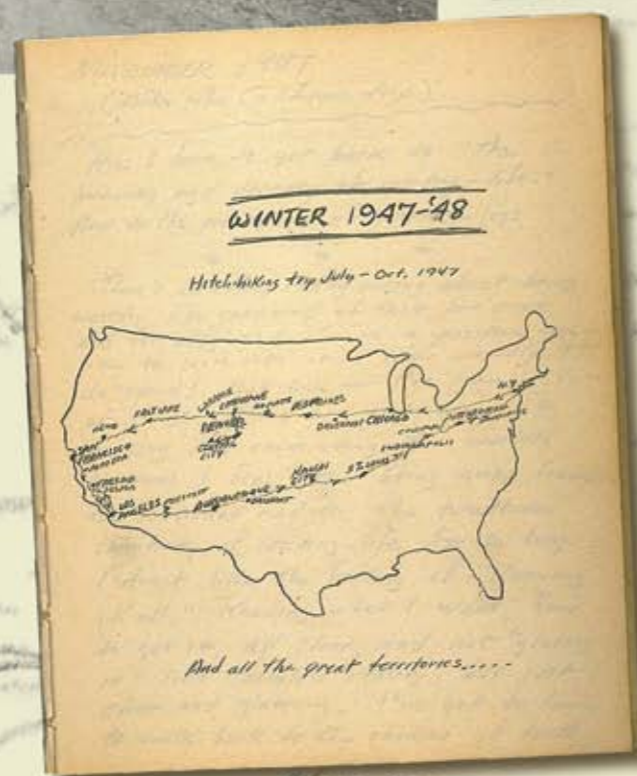

And all the great territories....



Greyhound







**Risto Bar**  
Restaurant Café

**WALL**  
Graphite · Nut · Ground  
60x120 cm

**FLOOR**  
Graphite · Beige  
Plate 9x30 cm

Beige · Grey · Nut  
Diamond 18x18 cm

• Interior Design p. 106



Temi d'ambiente  
Interior compositions

PLAY  
ONE

La Casa della Scrittrice  
The House of the Writer



KREA SNOW

KREA SILVER

CONCRETE GRAPHITE

CONCRETE GREY

CONCRETE SMOKE

CONCRETE ICE

La raffinatezza dei bianchi e neri è ciò che contraddistingue la casa della scrittrice.

Refined blacks and whites distinguish the home of the writer.



La calda riservatezza di una casa immersa nel silenzio,  
fuori un giardino curato pieno di fiori.  
Libri, un tavolo ingombro di fogli.  
Stanze che dichiarano con stile che questa casa è anche  
un ambiente di lavoro e di studio, un luogo dove nascono  
racconti fatti di parole meditate.

Un'atmosfera intima e personale, una classicità  
che si ritrova negli arredi, nelle superfici a tinte neutre  
che si caratterizzano in alti contrasti,  
fino a citare il nero su bianco della scrittura.



The warm intimacy of a house  
surrounded by silence,  
outside a well-loved garden full  
of flowers.  
Books, a table littered with papers.  
Rooms declare, with style,  
that this house is also a place for  
work and study, a place where novels  
are born of thoughtful words.

Cherished and personal, classic  
in its furnishings and in its surfaces  
in their neutral colors characterized  
by high contrast, citing the black  
white of the written word.

**Soggiorno 1**  
Living room 1

FLOOR

**Brown**  
Octagon 30x30 cm

**White**  
Button 3x3 cm

- Interior Design p. 107





**Soggiorno 2**  
Living room 2

FLOOR

**Ice**  
Octagon 30x30 cm  
30x30 cm

**Graphite**  
Button 3x3 cm  
30x30 cm

- Interior Design p. 108



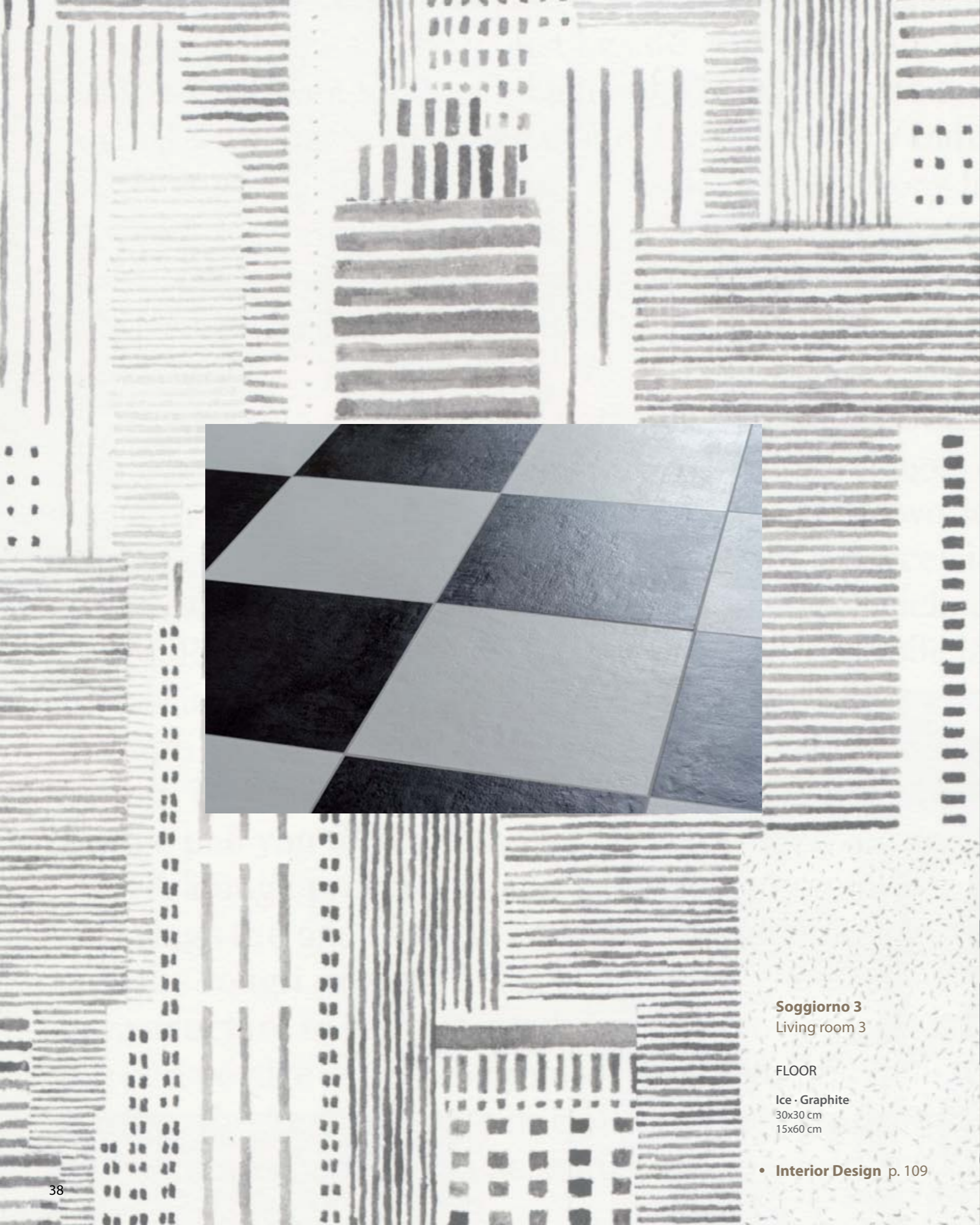

**Soggiorno 3**  
Living room 3

FLOOR

Ice · Graphite  
30x30 cm  
15x60 cm

• Interior Design p. 109





L'arte di scrivere storie sta nel saper tirar fuori da quel nulla che si è capito della vita tutto il resto; ma finita la pagina si riprende la vita e ci s'accorge che quel che si sapeva è proprio un nulla.  
*(Italo Calvino, Il cavaliere inesistente)*

The art of writing stories is knowing how to pull something out of life that you have understood from all the rest; but once finished the page, life resumes and you realize that what you know is in fact nothing at all.  
*(Italo Calvino, The nonexistent knight)*

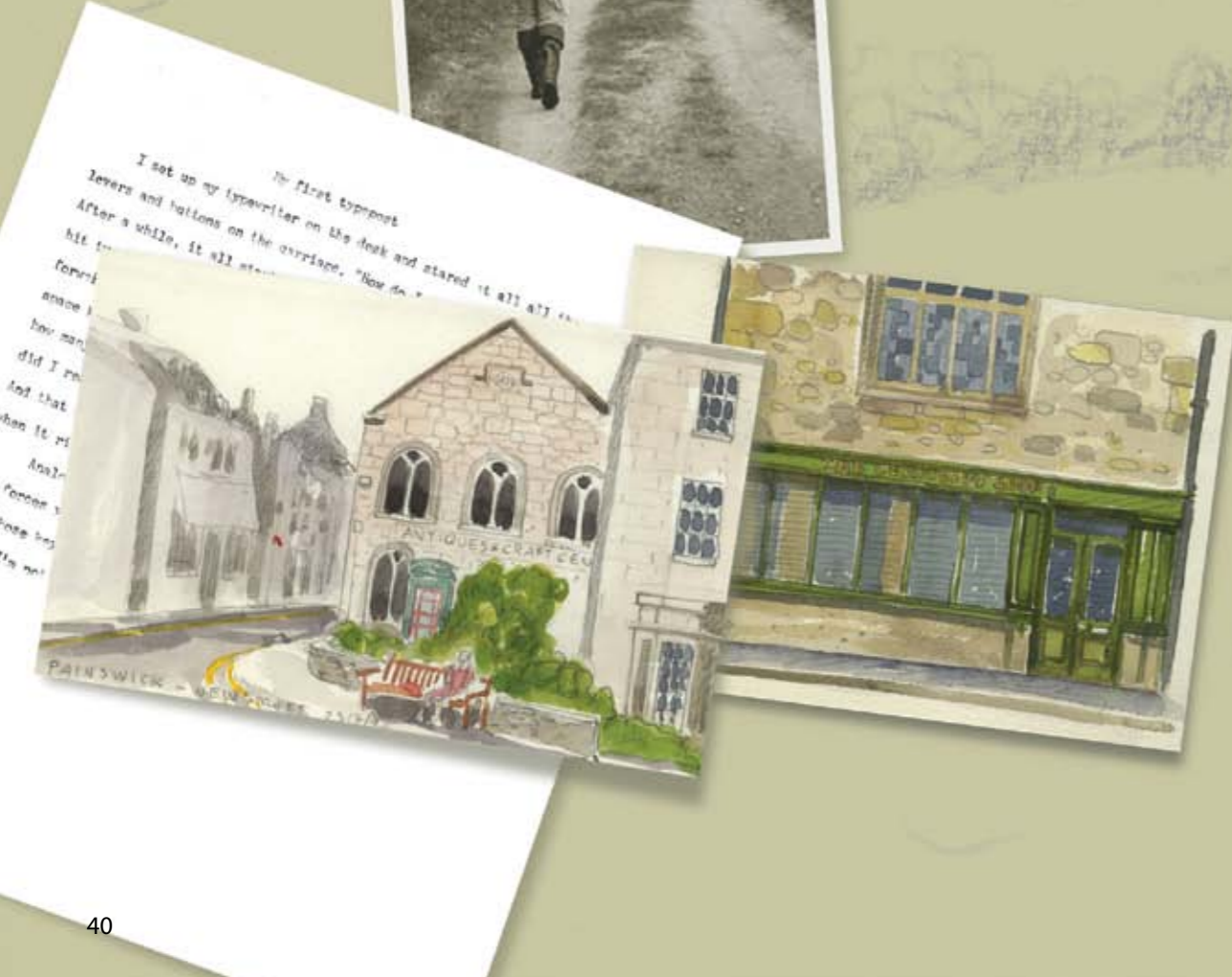





**Ingresso**  
Entrance

**FLOOR**

**Ice · Graphite · Snow**  
Diamond 18x18 cm

**Ice · Snow**  
Plate 9x30 cm

**Graphite**  
30x60 cm

- **Interior Design** p. 110







**Cucina 1**  
Kitchen 1

**WALL**

**Ice · Graphite**  
Diamond 18x18 cm

**Ice**  
Skirting 7.5x120 cm  
10x60 cm

**FLOOR**

**Beige**  
120x120 cm

• **Interior Design** p. 111







**Bagno**  
Bathroom

**WALL**  
Ice · White · Rope  
Diamond 18x18 cm

**Ice**  
15x60 cm  
10x60 cm

**FLOOR**  
Rope  
60x120 cm  
**White**  
Stripe Mosaic 15x120 cm [1 stripe 1.5x120 cm]

• Interior Design p. 112



Scrivere un romanzo è come guidare una macchina di notte: non puoi mai vedere oltre i fari, ma puoi viaggiare liberamente sulla strada.  
*(Edgar Lawrence Doctorow)*

Writing a novel is like driving a car at night: you cannot ever see beyond the headlights, but you are able to travel freely along the road.  
*(Edgar Lawrence Doctorow)*







**Patio**  
Patio

**WALL**

Ice · Graphite · Smoke  
20x120 cm

Beige · Rope  
Stripe Mosaic 15x120 cm [1 stripe 1.5x120 cm]

• **Interior Design** p. 113



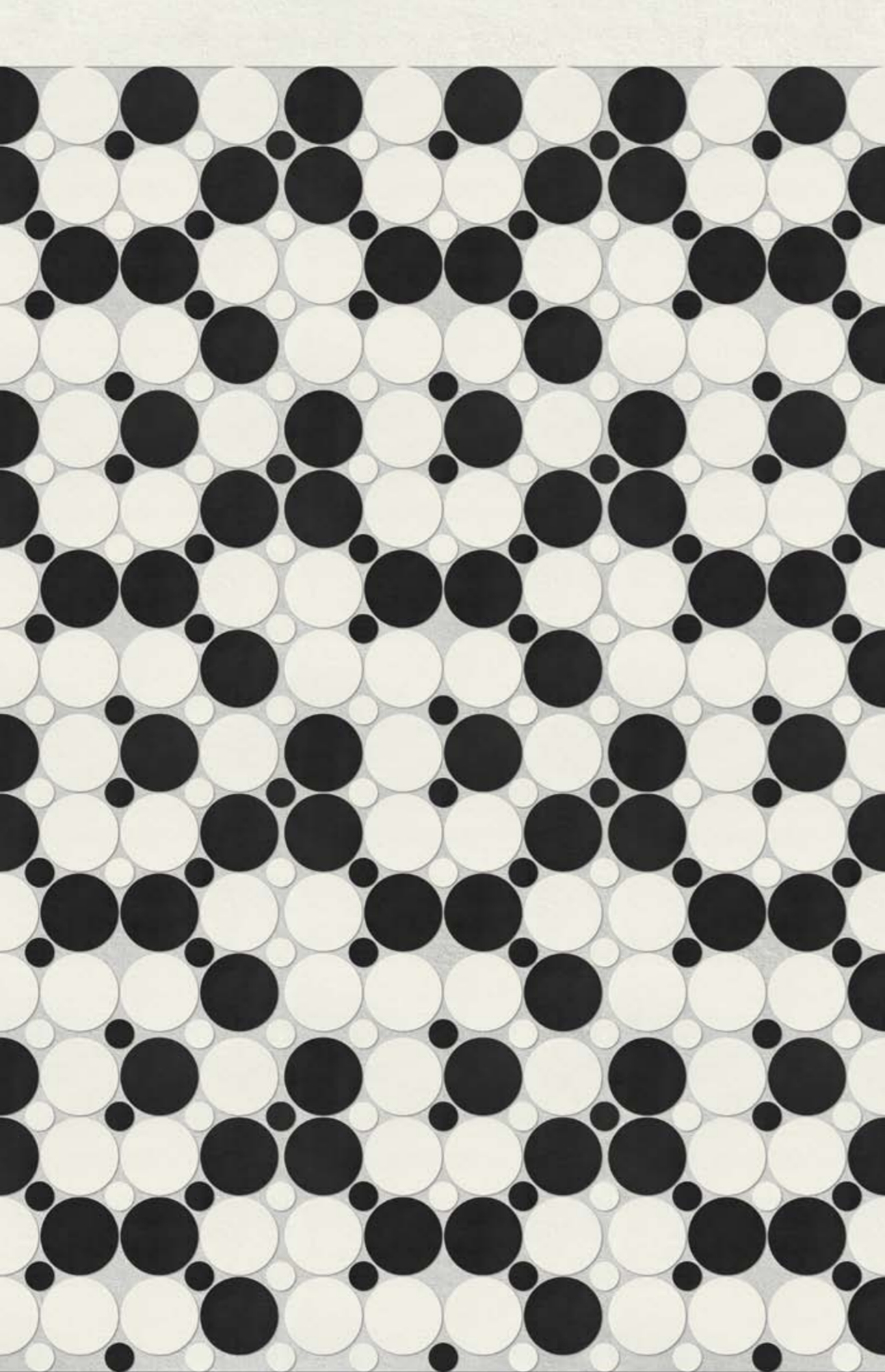

**Cucina 2**  
Kitchen 2

- WALL
- Ice · Graphite**  
Circle Mosaic big mix 30x30 cm
  - Ice**  
Skirting 7.5x120 cm  
10x60 cm
  - Graphite**  
20x120 cm

• Interior Design p. 114





# Temi d'ambiente

Interior compositions

PLAY  
ONE

## La Casa del Navigatore

The House of the Seafarer



CONCRETE GREY

KREA BLUE

KREA SNOW

CONCRETE ICE

CONCRETE SMOKE

La luminosità dei blu con i bianchi è ciò che contraddistingue la casa del navigatore.

The brightness of blues and whites distinguishes the home of the seafarer.



Svegliarsi in una mattina d'inverno e passeggiare sulla spiaggia sferzata dal vento. Raccogliere piccoli relitti di rami restituiti dalle onde.

Poi tornare al tepore della casa: i colori del mare che entrano sulle superfici inondate di luce, sugli arredi, sugli oggetti che ricordano che presto si salperà per una nuova crociera.

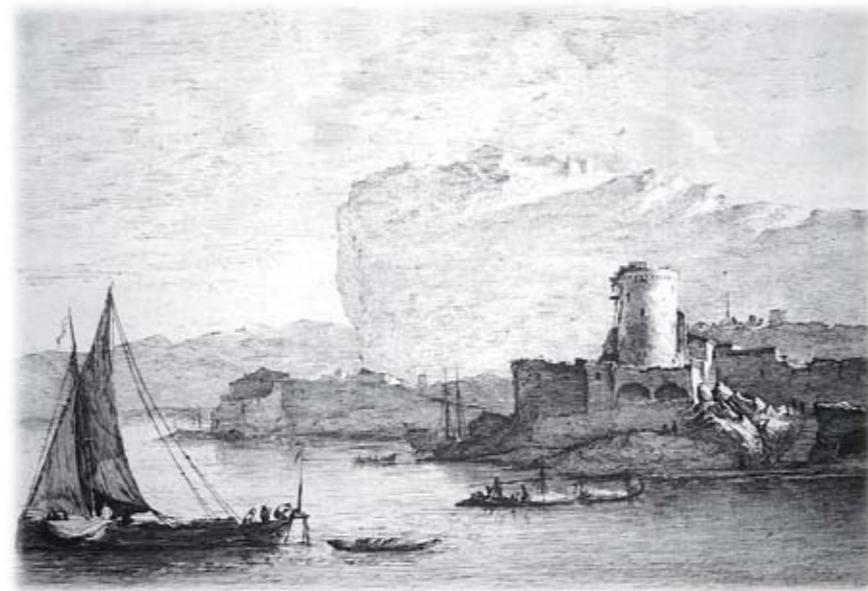

Waking up on a winter's morning and walking along the windswept beach, collecting driftwood relinquished by the waves.

Then going back to the warmth of home: the colors of the sea reflected on surfaces bathed in light, on the furnishings, objects reminding you that soon it will be time to set sail on yet a new expedition.

**Ingresso**  
Entrance

FLOOR

**Blue · Graphite · Ice**  
Diamond 18x18 cm

**Blue · Ice**  
15x60 cm

**Graphite**  
Stripes Mosaic 15x120 cm  
[3 stripes 1.5x120 cm]

• Interior Design p. 115





**Cucina**  
Kitchen**WALL****Ice**  
120x120 cm  
60x120 cm**FLOOR****Blue · Snow**  
30x30 cm**Ice**  
Plate 9x30 cm  
Small 9x9 cm

• Interior Design p. 116





**Zoom Cucina**  
Zoom Kitchen

FLOOR  
**Blue · Snow**  
30x30 cm

Ice  
Plate 9x30 cm  
Small 9x9 cm

• **Interior Design** p. 116





Zona notte 1  
Bedroom 1

WALL  
Snow · Ground · Nut  
20x120 cm

Orange · Blue · Green · Red  
Stripe Mosai 15x120 cm  
[1 stripe 1.5x120 cm]

• Interior Design p. 117







**Zona notte 2**  
Bedroom 2

**WALL**

**White**  
120x120 cm

**FLOOR**

**White · Blue**  
Diamond 18x18 cm  
10x60 cm

**White**  
20x120 cm

• **Interior Design** p. 118





Non avevo mai veduto il mare. Molte altre cose avevo visto, forse troppe.  
Uomini avevo visto, forse troppi. Ma il mare mai.  
E perciò non avevo ancora compreso nulla, non avevo capito assolutamente nulla.  
*(Federico García Lorca)*

I have never seen the sea. I have seen many other things, perhaps too many.  
I have seen men, perhaps too many. But never the sea.  
And so I have not yet understood anything, I have understand absolutely nothing.  
*(Federico García Lorca)*







**Bagno**  
Bathroom

**WALL**  
Silver  
120x120 cm  
Stripes Mosaic 15x120 cm  
[2 stripes 1.5x120 cm]

**FLOOR**  
Ice · Blue  
Diamond 18x18 cm  
Ice  
30x30 cm  
Blue  
Plate 9x30 cm

• Interior Design p. 119







**Soggiorno**  
Living room

**FLOOR**

**White**  
60x120 cm  
Plate 9x30 cm

**Rope**  
Plate 9x30 cm

• **Interior Design** p. 120

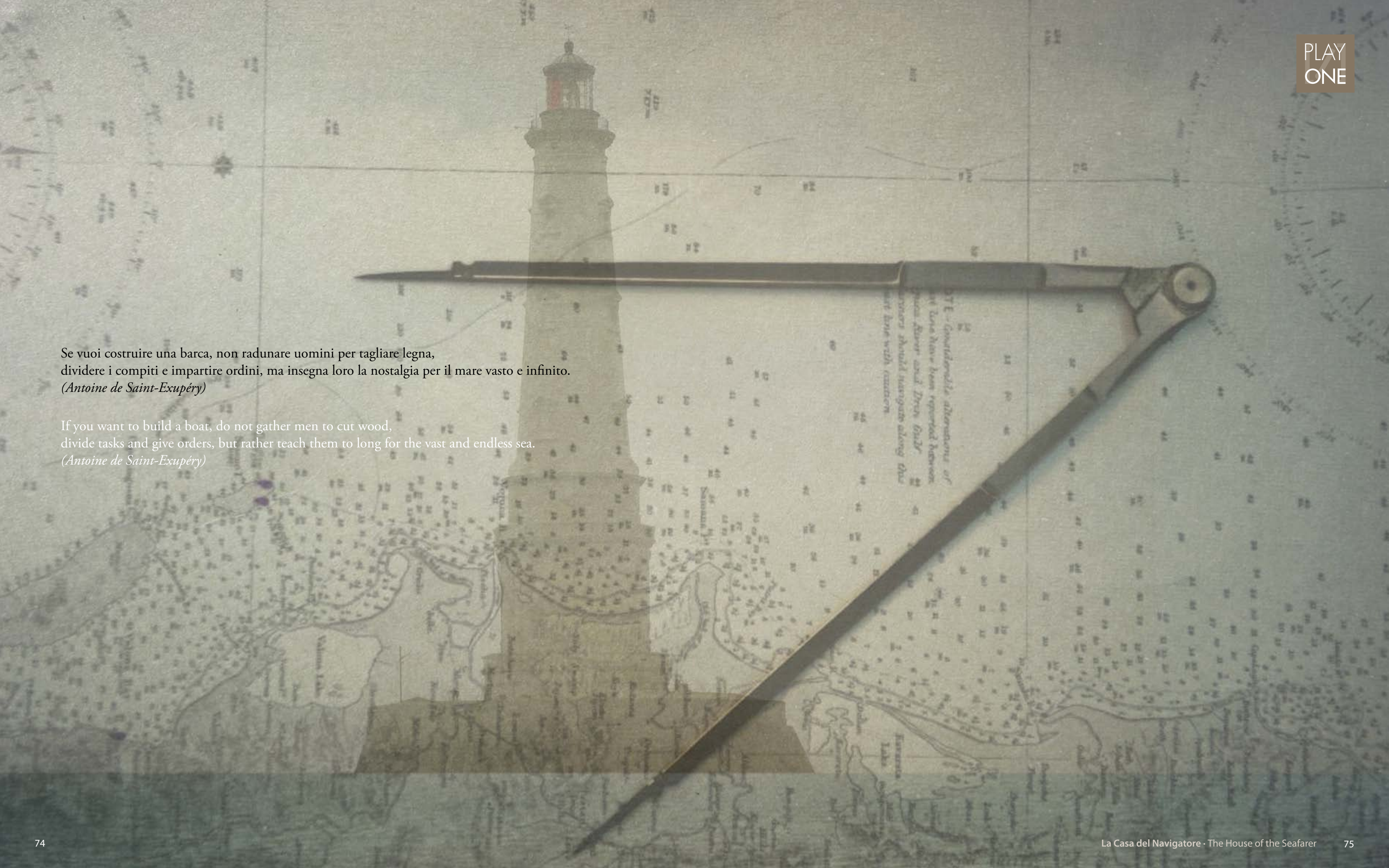

A vintage nautical chart with a lighthouse and a compass. The chart is a detailed map of a coastal area, featuring a prominent lighthouse on a rocky island. A large, dark compass is placed over the chart, its needle pointing towards the top. The chart includes various navigational details such as depth soundings, bearings, and names of geographical features. The overall tone is sepia and historical.

Se vuoi costruire una barca, non radunare uomini per tagliare legna,  
dividere i compiti e impartire ordini, ma insegna loro la nostalgia per il mare vasto e infinito.  
*(Antoine de Saint-Exupéry)*

If you want to build a boat, do not gather men to cut wood,  
divide tasks and give orders, but rather teach them to long for the vast and endless sea.  
*(Antoine de Saint-Exupéry)*



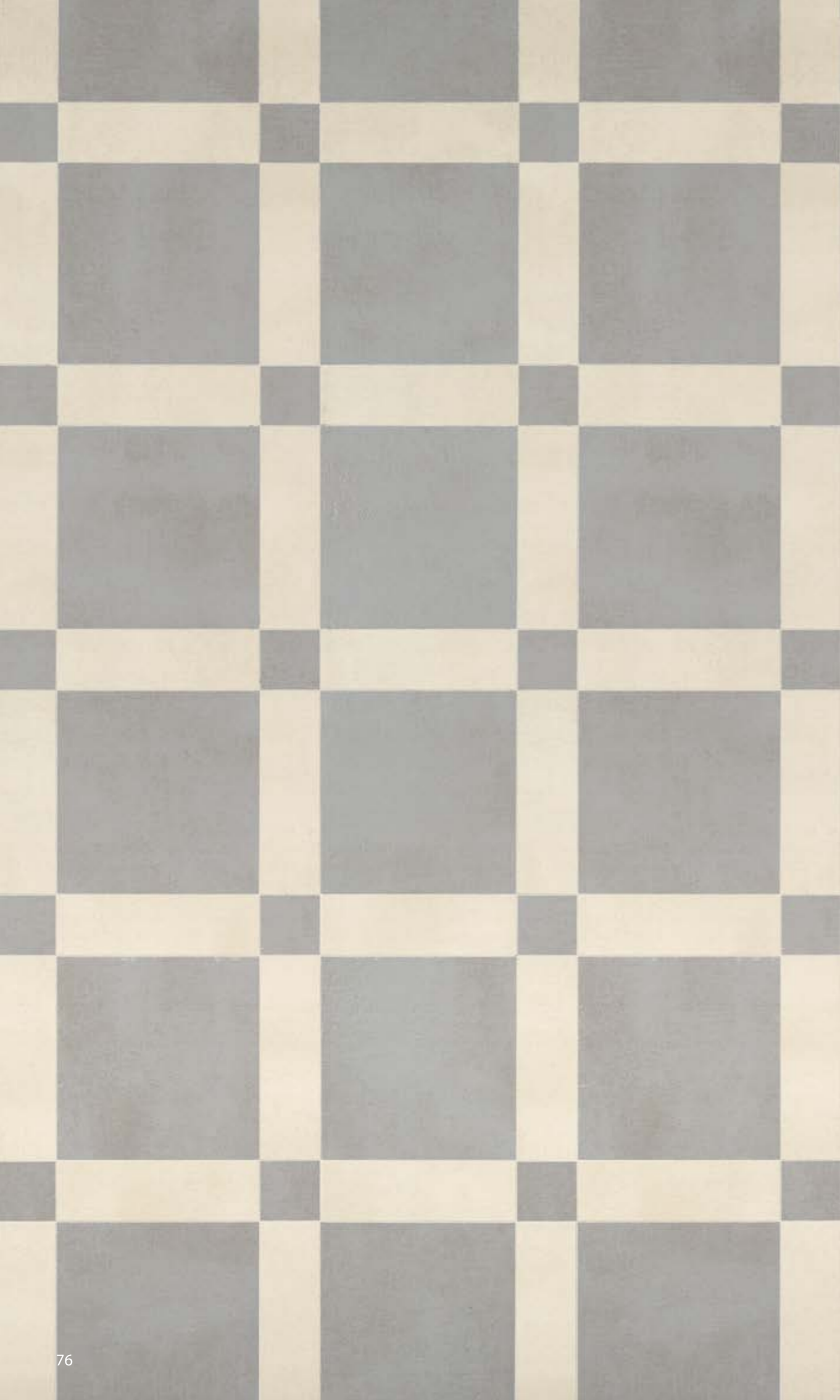

**Ristorante**  
Restaurant

**FLOOR**

**Rope**  
30x30 cm

**White**  
Plate 9x30 cm  
Small 9x9 cm

- **Interior Design** p. 121







Temi d'ambiente  
Interior compositions

PLAY  
ONE

La Casa del Musicista  
The House of the Musician





KREA GREEN

KREA RED

CONCRETE GRAPHITE

KREA SILVER

La classicità del rosso e verde è ciò che contraddistingue la casa del musicista.

Classic reds and greens distinguish the home of the musician.



*- Ieri è venuto John da Ginevra: la voce sabbiosa,  
satinata del suo sax tenore ha invaso le stanze, creando  
un'atmosfera in grande sintonia con l'ambiente.*

*... Verrà un gran concerto. -*

Superfici calde, textures satinata in tonalità naturali  
dialogano in armonia con gli ambienti e gli arredi  
di una casa di prestigio, ambienti contemporanei  
di una classicità senza tempo.

*- Yesterday John came from Geneva:  
the sandy satin voice of his  
tenor sax invaded the rooms,  
creating an atmosphere in harmony with  
the surroundings.*

*... It will be a great concert. -*

Warm surfaces, satin textures in natural tones  
blend melodiously with the interiors and  
furnishings of a distinguished house,  
contemporary settings of a timeless classic.



**Ingresso**  
Entrance

FLOOR

**Green · Silver**  
30x30 cm

**Red**  
Diamond 18x18 cm

**Silver**  
Plate 9x30 cm  
Brick 9x18 cm  
20x120 cm

• Interior Design p. 122

PLAY  
ONE







**Stanze**  
Rooms

**FLOOR**  
Green · White · Red · Silver  
30x30 cm  
**Silver**  
Stripes Mosaic 15x120 cm  
[2 stripes 1.5x120 cm]

• **Interior Design** p. 123





“Le note mi arrivano come un vapore sottile, come vapore acqueo.  
E io cerco di coglierne la forma prima che svaniscano nell’aria.”  
*(Keith Jarrett)*

“The notes come to me in a subtle vapor, like steam.  
And I try to grasp their form before they disappear into thin air.”  
*(Keith Jarrett)*







**Soggiorno**  
Living room

**WALL**  
Beige  
120x120 cm

**FLOOR**  
White · Brown · Beige · Green  
30x30 cm

**Graphite**  
30x30 cm

**Beige**  
Plate 9x30 cm

• Interior Design p. 124





**Zoom Soggiorno**  
Zoom Living room

FLOOR  
White · Brown · Beige · Green  
30x30 cm

• **Interior Design** p. 124





**Zona notte**  
Bedroom

**FLOOR**  
Green · Red · Snow  
Diamond 18x18 cm

• **Interior Design** p. 125







**Ristorante**  
Restaurant

**WALL**

**Rope**  
120x120 cm  
60x120 cm

**Green**  
Stripes Mosaic 15x120 [1 stripe 1.5x120 cm]

**FLOOR**

**Snow · Ground · Red · Green**  
30x30 cm

• Interior Design p. 126



Tre cose sono necessarie per un buon pianista: la testa, il cuore e le dita.  
*(Wolfgang Amadeus Mozart)*

Three things necessary for a good pianist: the head, the heart and the fingers.  
*(Wolfgang Amadeus Mozart)*



Concrete



Krea





La Casa dell'Esploratore · The House of the Explorer



INGRESSO Esploratore

p. 13

ENTRANCE Explorer

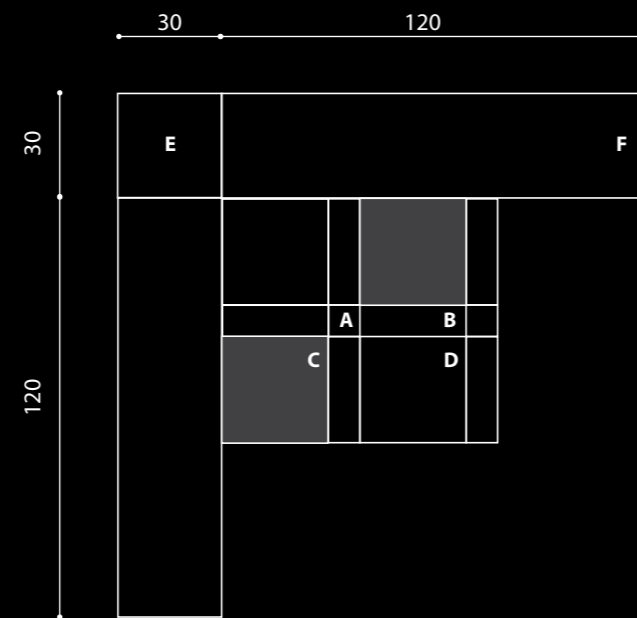

**LAYOUT 5.3**

- A Small 9x9 cm · Krea Nut 5.33% · 6.57 pcs/sqm
- B Plate 9x30 cm · Krea Nut 35.50% · 13.15 pcs/sqm
- C 30x30 cm · Concrete Beige 29.59% · 3.29 pcs/sqm
- D 30x30 cm · Concrete White 29.59% · 3.29 pcs/sqm

**ALTRI FORMATI · OTHER SHAPES**

- E 30x30 cm · Krea Nut
- F 30x120 cm · Krea Nut

SOGGIORNO 1 Esploratore

p. 15

LIVING ROOM 1 Explorer

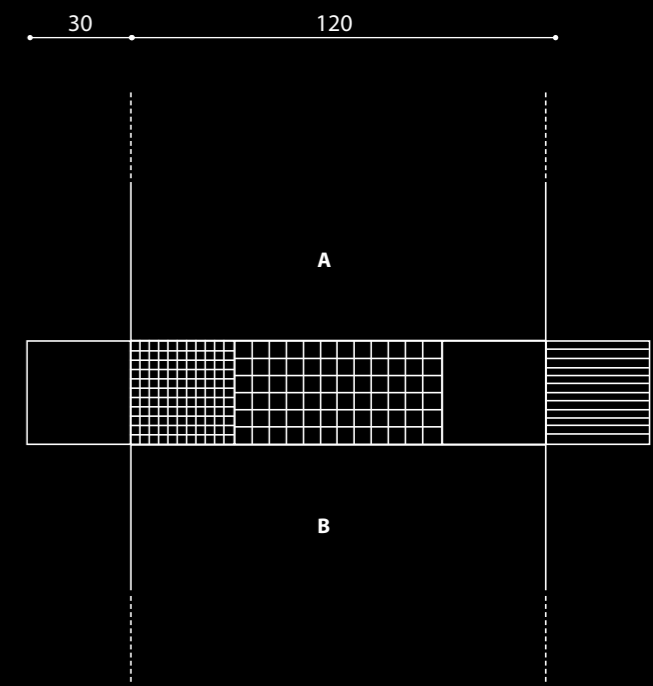
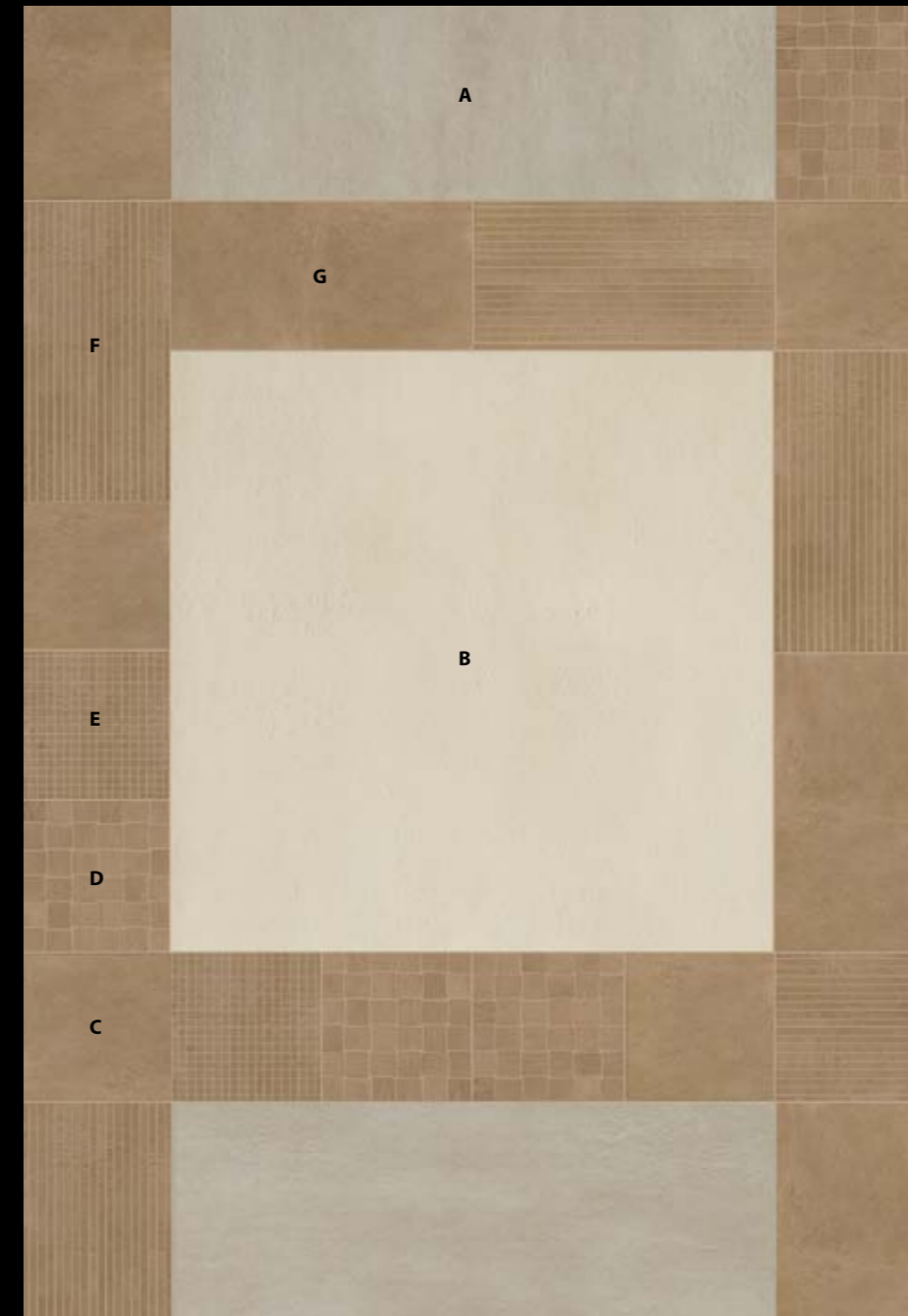
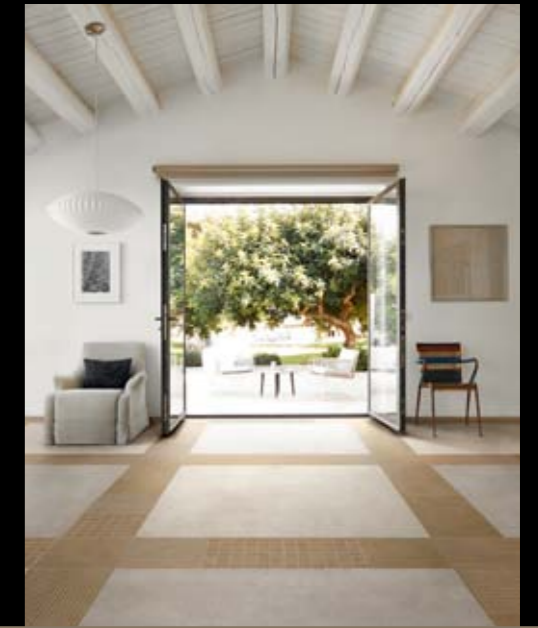

- A 120x120 cm · Concrete Rope
- B 120x120 cm · Concrete White
- C 30x30 cm · Concrete Beige
- D Action Mosaic 30x30 cm · Concrete Beige
- E Mosaic 30x30 cm · Concrete Beige
- F Stripes Mosaic 30x60 cm · Concrete Beige
- G 30x60 cm · Concrete Beige



La Casa dell'Esploratore · The House of the Explorer



**SOGGIORNO 2** Esploratore

p. 16

LIVING ROOM 2 Explorer

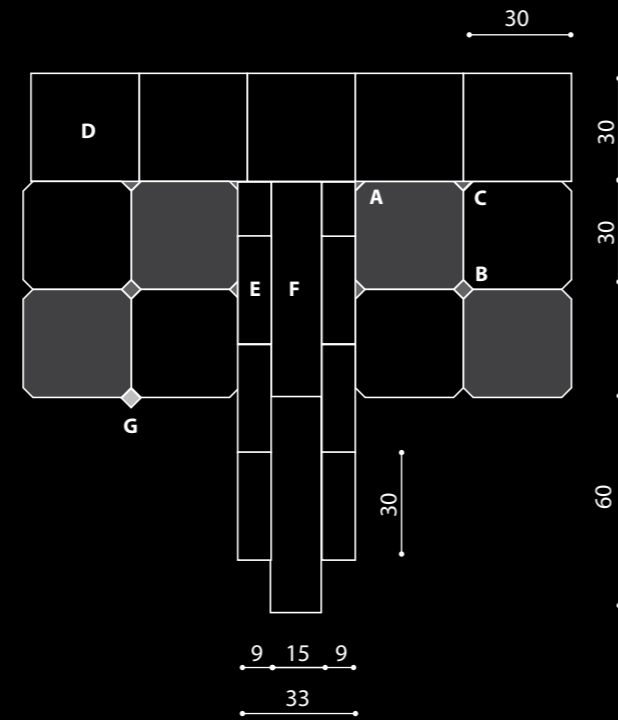

**LAYOUT 6.3**

- A** Octagon 30x30 cm · Concrete Graphite 49.50% · 5.61 pcs/sqm
- B** Button 3x3 cm · Concrete Rope 1% · 11.22 pcs/sqm
- C** Octagon 30x30 cm · Concrete Brown 49.50% · 5.61 pcs/sqm

**ALTRI FORMATI · OTHER SHAPES**

- D** 30x30 cm · Concrete Brown
- E** Plate 9x30 cm · Concrete Brown
- F** 15x60 cm · Concrete Brown
- G** Button 3x3 cm · Krea Red

**CUCINA** Esploratore

p. 19

KITCHEN Explorer



**RIV · WALL**

- A** Action Mosaic 30x30 cm · Concrete Rope
- B** 15x60 cm · Concrete Rope

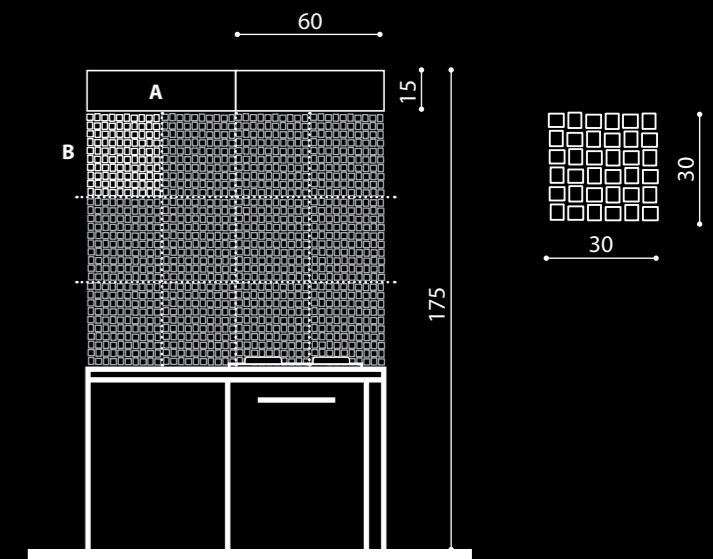

**PAV · FLOOR**

**LAYOUT 6.3**

Graphite · Brown · Rope · Red

**SOGGIORNO 2** Esploratore  
LIVING ROOM 2 Explorer





La Casa dell'Esploratore · The House of the Explorer



BAGNO Esploratore

p. 22

BATHROOM Explorer

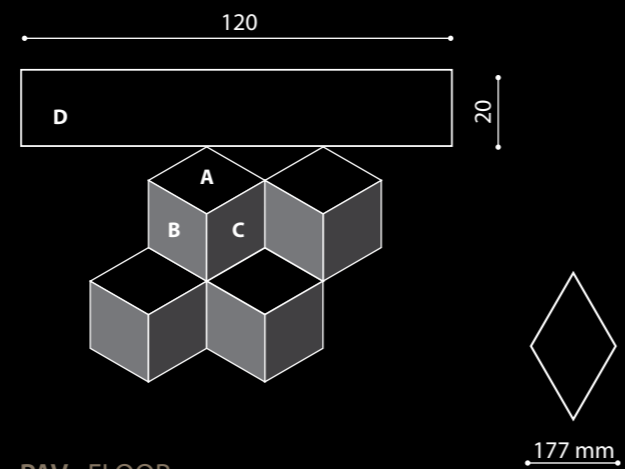

PAV · FLOOR

LAYOUT 7.3

- A Diamond 18x18 cm · Concrete Beige 33.33% · 12.30 pcs/sqm
- B Diamond 18x18 cm · Krea Orange 33.33% · 12.30 pcs/sqm
- C Diamond 18x18 cm · Concrete White 33.33% · 12.30 pcs/sqm

ALTRI FORMATI · OTHER SHAPES

- D 20x120 cm · Krea Orange

RIV · WALL

- E 120x120 cm · Krea Orange
- F Stripes Mosaic 15x120 cm [3 stripes 1.5x120 cm] · Krea Orange

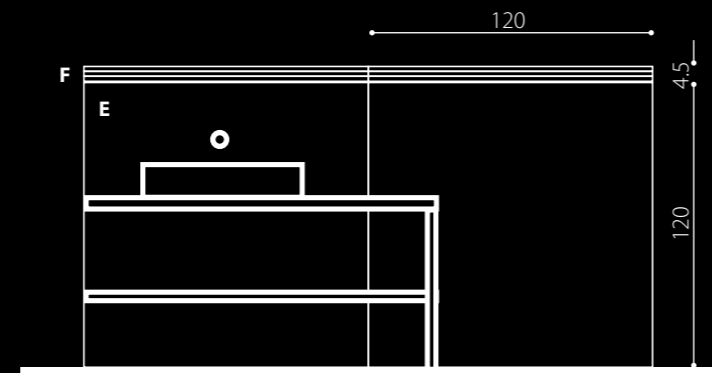

VANO SCALA Esploratore

p. 25

STAIRWELL Explorer

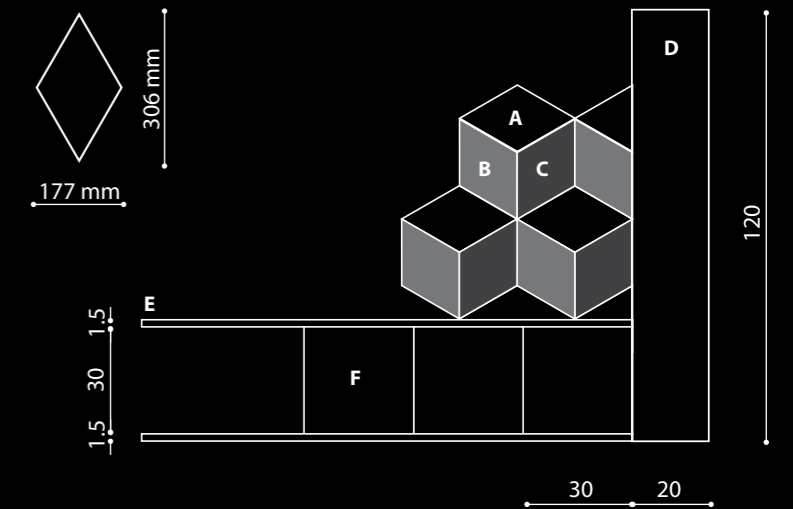

LAYOUT 7.3

- A Diamond 18x18 cm · Concrete Beige 33.33% · 12.30 pcs/sqm
- B Diamond 18x18 cm · Concrete White 33.33% · 12.30 pcs/sqm
- C Diamond 18x18 cm · Krea Orange 33.33% · 12.30 pcs/sqm

ALTRI FORMATI · OTHER SHAPES

- D 20x120 cm · Krea Orange
- E Stripes Mosaic 15x120 cm [1 stripe 1.5x120 cm] · Concrete White
- F 30x30 cm · Krea Orange



La Casa dell'Esploratore · The House of the Explorer



RISTO BAR Esploratore

p. 28

RESTAURANT CAFÉ Explorér

La Casa della Scrittrice · The House of the Writer



SOGGIORNO 1 Scrittrice

p. 35

LIVING ROOM 1 Writer



PAV · FLOOR

LAYOUT 7.3

- A Diamond 18x18 cm · Concrete Grey 33.33% · 12.30 pcs/sqm
- B Diamond 18x18 cm · Concrete Beige 33.33% · 12.30 pcs/sqm
- C Diamond 18x18 cm · Krea Nut 33.33% · 12.30 pcs/sqm

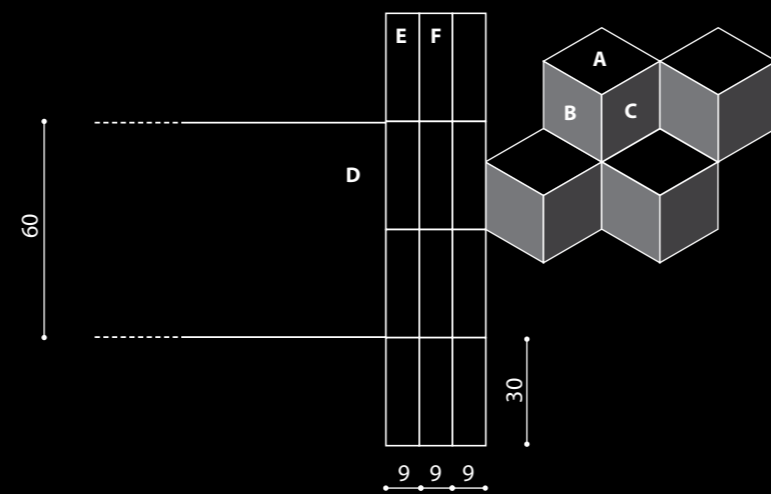

ALTRI FORMATI · OTHER SHAPES

- D 60x120 cm · Concrete Beige
- E Plate 9x30 cm · Concrete Beige
- F Plate 9x30 cm · Concrete Graphite



RIV · WALL

60x120 cm · Concrete Graphite · Krea Nut · Krea Ground

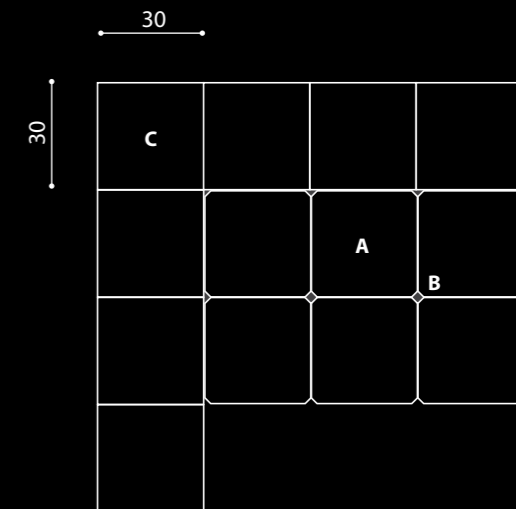

LAYOUT 6.2

- A Octagon 30x30 cm · Concrete Brown 99% · 11.22 pcs/sqm
- B Button 3x3 cm · Concrete Rope 1% · 11.22 pcs/sqm

ALTRI FORMATI · OTHER SHAPES

- C 30x30 cm · Concrete Brown



La Casa della Scrittrice · The House of the Writer



**SOGGIORNO 2** Scrittrice

p. 36

LIVING ROOM 2 Writer

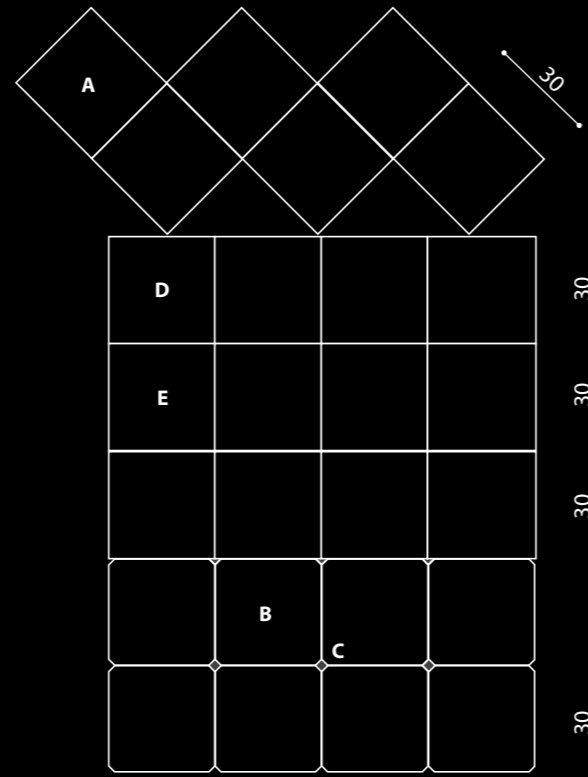
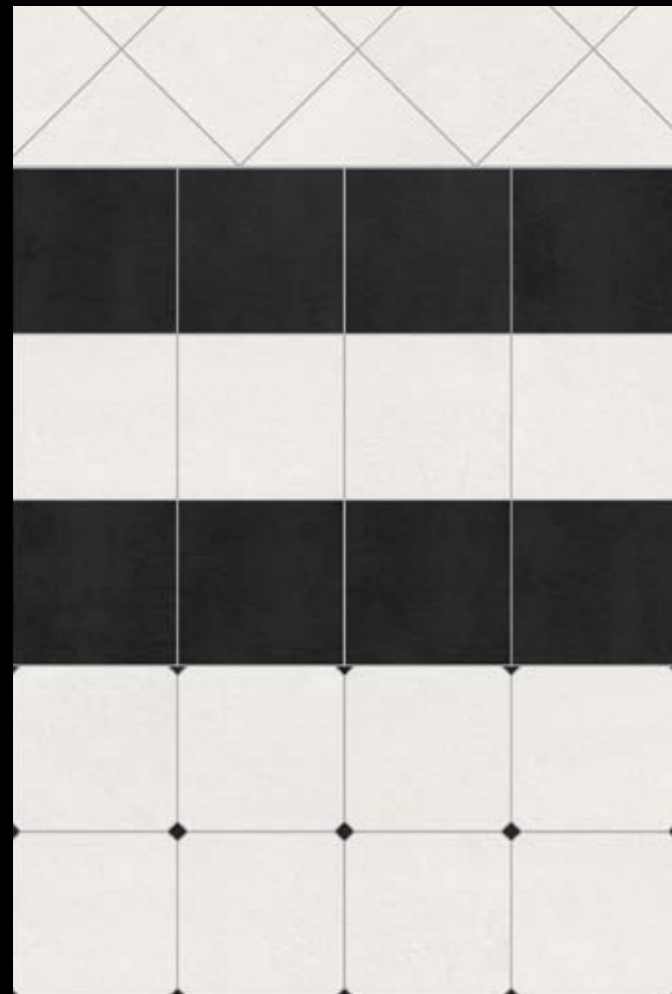

**LAYOUT 1.1**

**A** 30x30 cm · Concrete Ice 100% · 11.1 pcs/sqm

**LAYOUT 6.2**

**B** Octagon 30x30 cm · Concrete Ice 99% · 11.22 pcs/sqm  
**C** Button 3x3 cm · Concrete Rope 1% · 11.22 pcs/sqm

**ALTRI FORMATI · OTHER SHAPES**

**D** 30x30 cm · Concrete Graphite  
**E** 30x30 cm · Concrete Ice

**SOGGIORNO 3** Scrittrice

p. 39

LIVING ROOM 3 Writer

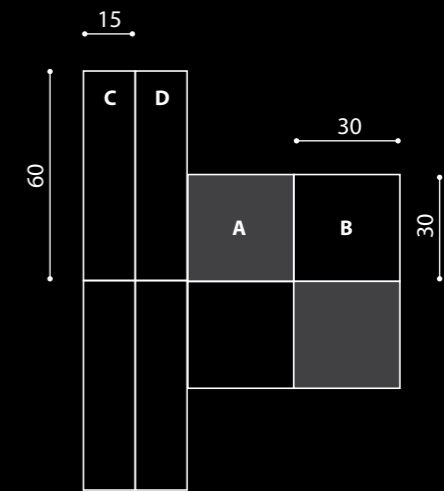
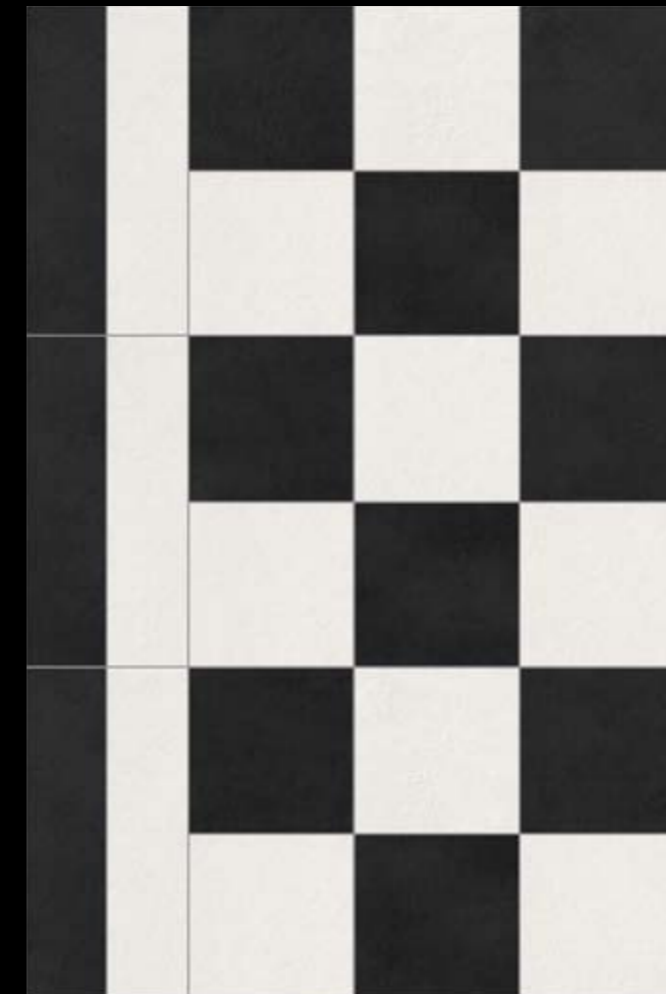

**LAYOUT 1.2**

**A** 30x30 cm · Concrete Graphite 50% · 5.6 pcs/sqm  
**B** 30x30 cm · Concrete Ice 50% · 5.6 pcs/sqm

**ALTRI FORMATI · OTHER SHAPES**

**C** 15x60 cm · Concrete Graphite  
**D** 15x60 cm · Concrete Ice



La Casa della Scrittrice · The House of the Writer



INGRESSO Scrittrice

p. 43

ENTRANCE Writer

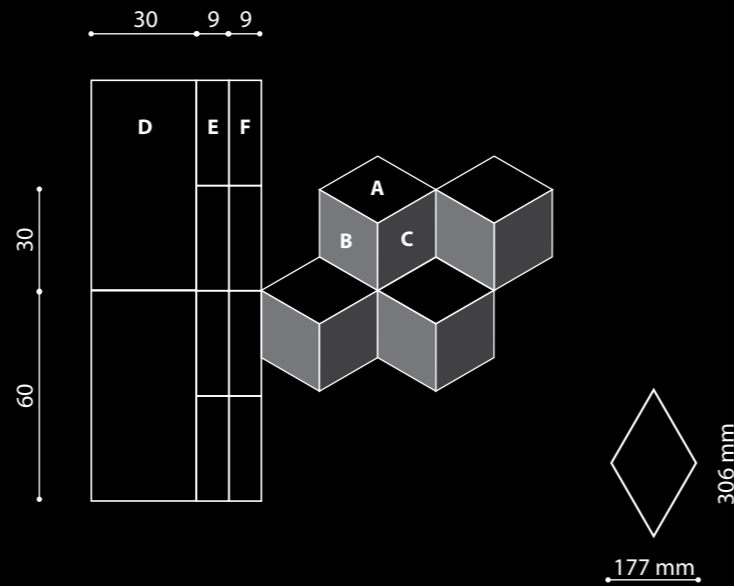

**LAYOUT 7.3**

- A Diamond 18x18 cm · Concrete Graphite 33.33% · 12.30 pcs/sqm
- B Diamond 18x18 cm · Krea Snow 33.33% · 12.30 pcs/sqm
- C Diamond 18x18 cm · Concrete Ice 33.33% · 12.30 pcs/sqm

**ALTRI FORMATI · OTHER SHAPES**

- D 60x30 cm · Concrete Graphite
- E Plate 9x30 cm · Krea Snow
- F Plate 9x30 cm · Concrete Ice

CUCINA 1 Scrittrice

p. 45

KITCHEN 1 Writer



**RIV · WALL**

**LAYOUT 8.2**

- A Diamond 18x18 cm · Concrete Ice 50% · 18.45 pcs/sqm
- B Diamond 18x18 cm · Concrete White 50% · 18.45 pcs/sqm

**ALTRI FORMATI · OTHER SHAPES**

- C Skirting 120x7.5 cm · Concrete Ice
- D 15x60 cm · Concrete Ice
- E 10x60 cm · Concrete Ice

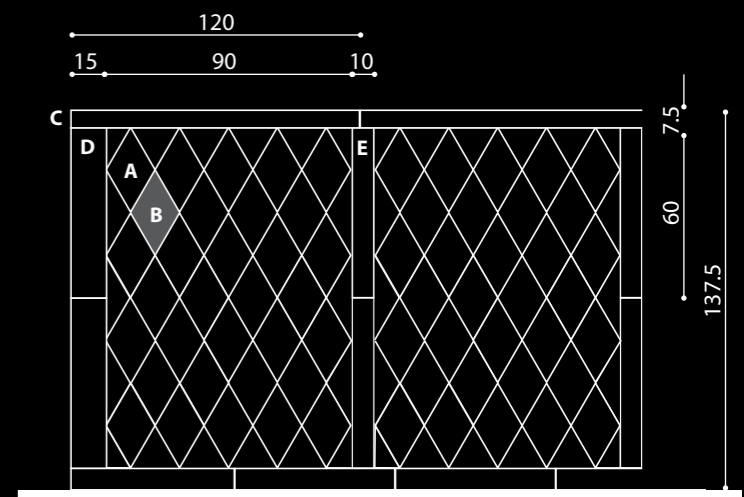
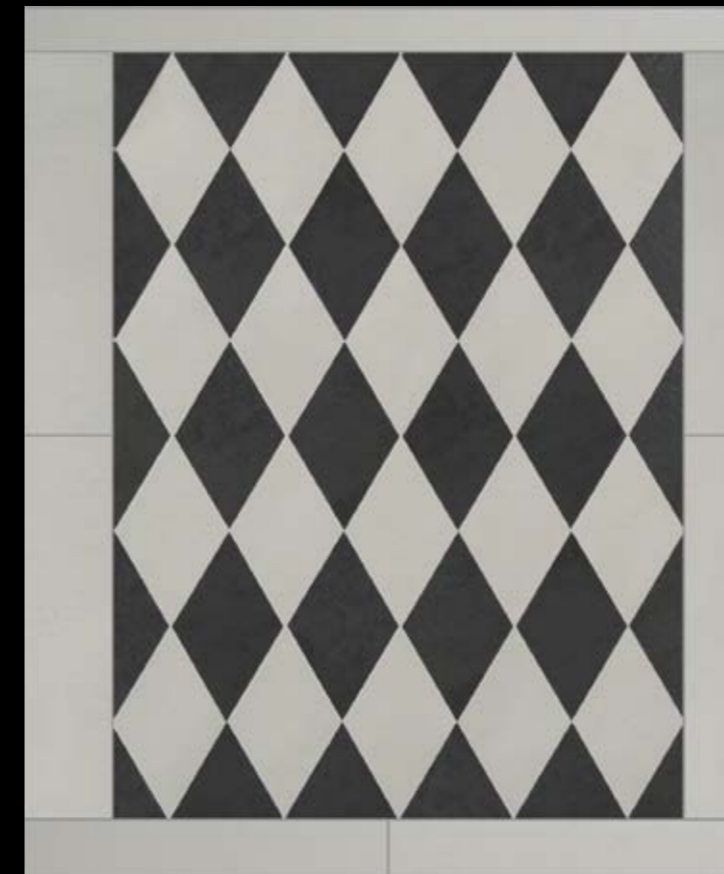

**PAV · FLOOR**

120x120 cm · Concrete Beige

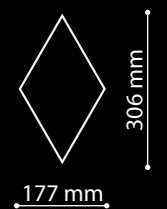



La Casa della Scrittrice · The House of the Writer



BAGNO Scrittrice

p. 46

BATHROOM Writer



PATIO Scrittrice

p. 50

PATIO Writer

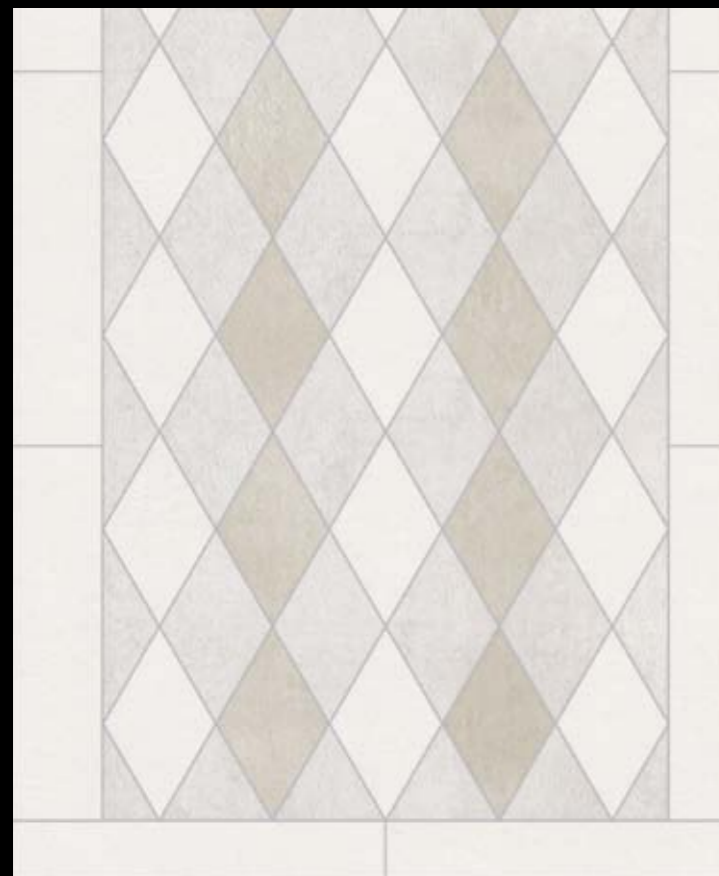

RIV · WALL

LAYOUT 8.4

- A Diamond 18x18 cm · Concrete Ice 25% · 9.23 pcs/sqm
- B Diamond 18x18 cm · Concrete White 50% · 18.45 pcs/sqm
- C Diamond 18x18 cm · Krea Rope 25% · 9.23 pcs/sqm

ALTRI FORMATI · OTHER SHAPES

- D 15x60 cm · Concrete Ice
- E 10x60 cm · Concrete Ice

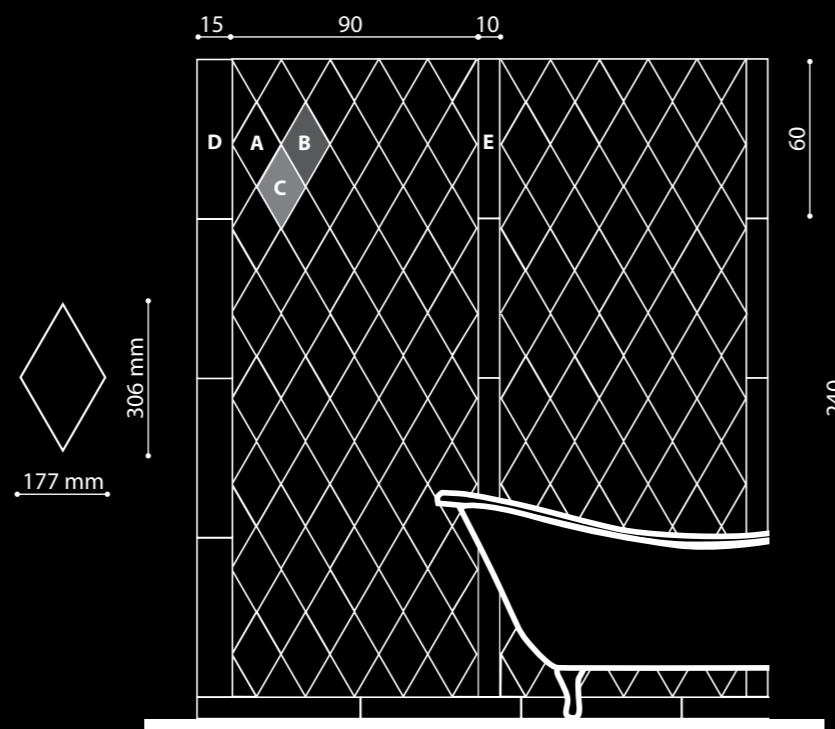

PAV · FLOOR

- F 60x120 cm · Concrete Rope
- G Stripes Mosaic 15x120 cm [1 stripe 1.5x120 cm] · Concrete White

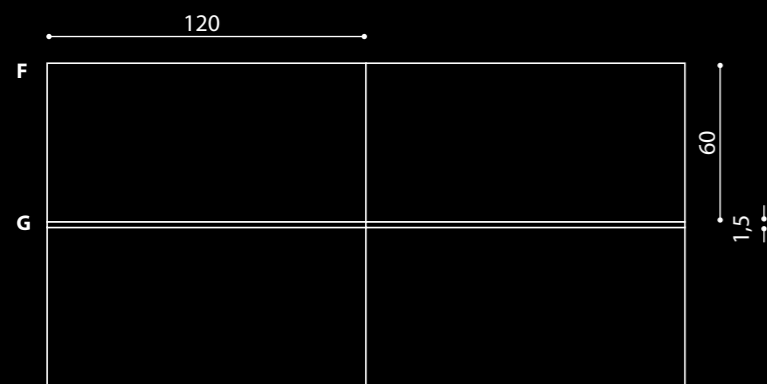

LAYOUT 14.3

- A 20x120 cm · Concrete Ice 31% · 1.3 pcs/sqm
- B 20x120 cm · Concrete Graphite 31% · 1.3 pcs/sqm
- C 20x120 cm · Concrete Smoke 31% · 1.3 pcs/sqm
- D Stripes Mosaic 15x120 cm · Concrete Beige [1 stripe 1.5x120 cm] 3.5% · 0.2 pcs/sqm
- E Stripes Mosaic 15x120 cm · Concrete Rope [1 stripe 1.5x120 cm] 3.5% · 0.2 pcs/sqm

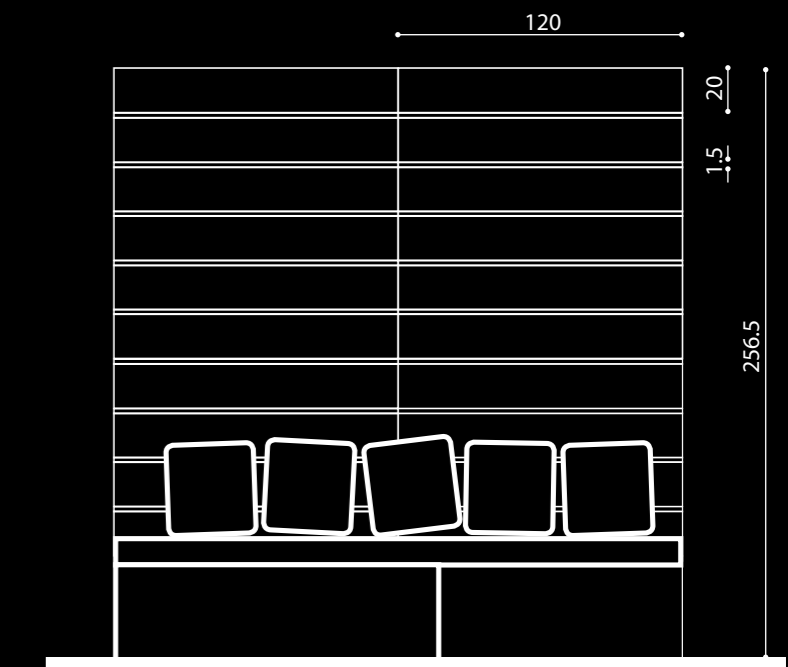



La Casa della Scrittrice · The House of the Writer



CUCINA 2 Scrittrice

p. 53

KITCHEN 2 Writer

La Casa del Navigatore · The House of the Seafarer



INGRESSO Navigatore

p. 59

ENTRANCE Seafarer

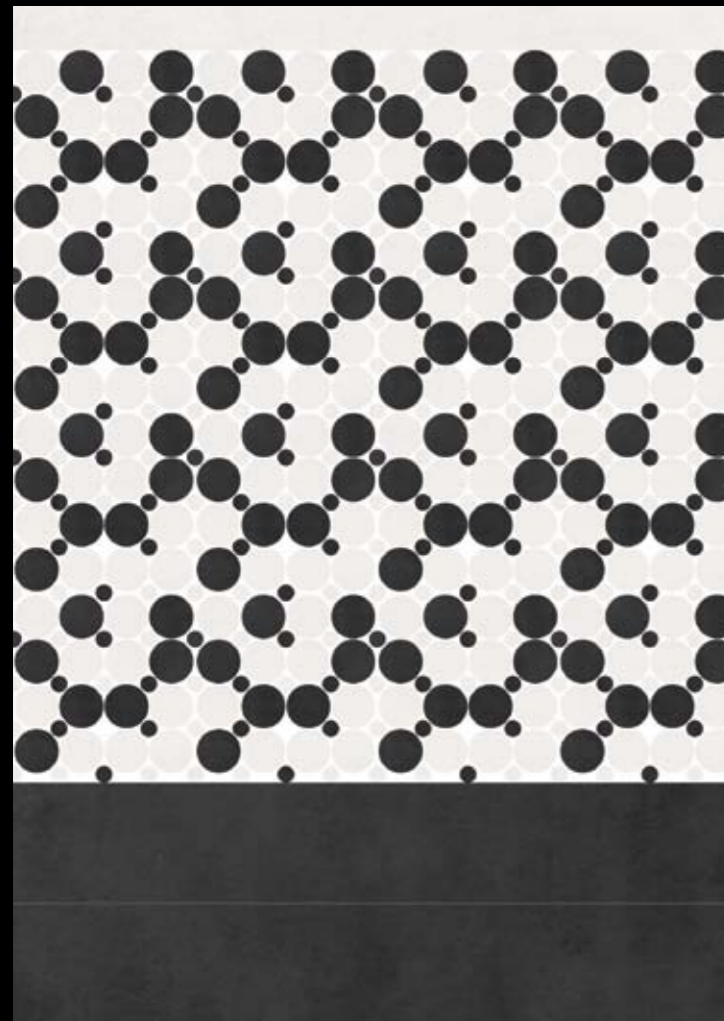

A Skirting 7.5x120 cm · Concrete Ice  
 B Circle Mosaic Big Mix 30x30 cm · Mix Concrete Ice / Concrete Graphite  
 C 20x120 cm · Concrete Graphite

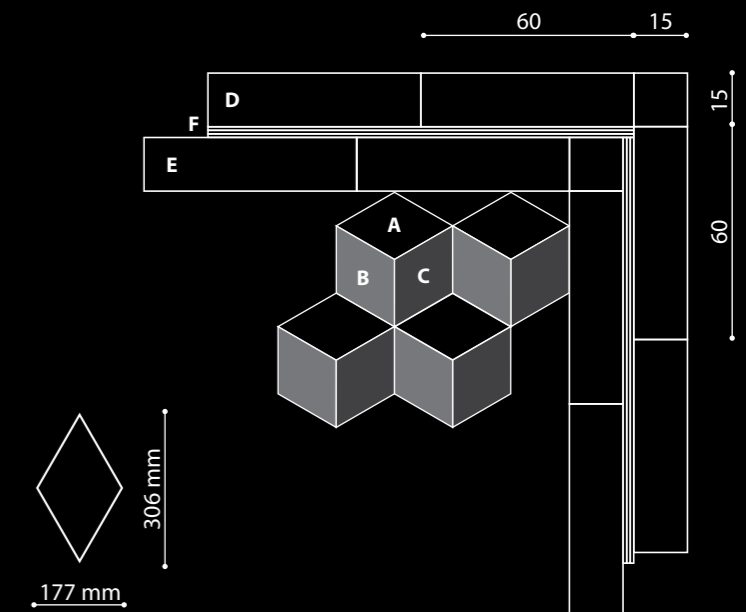
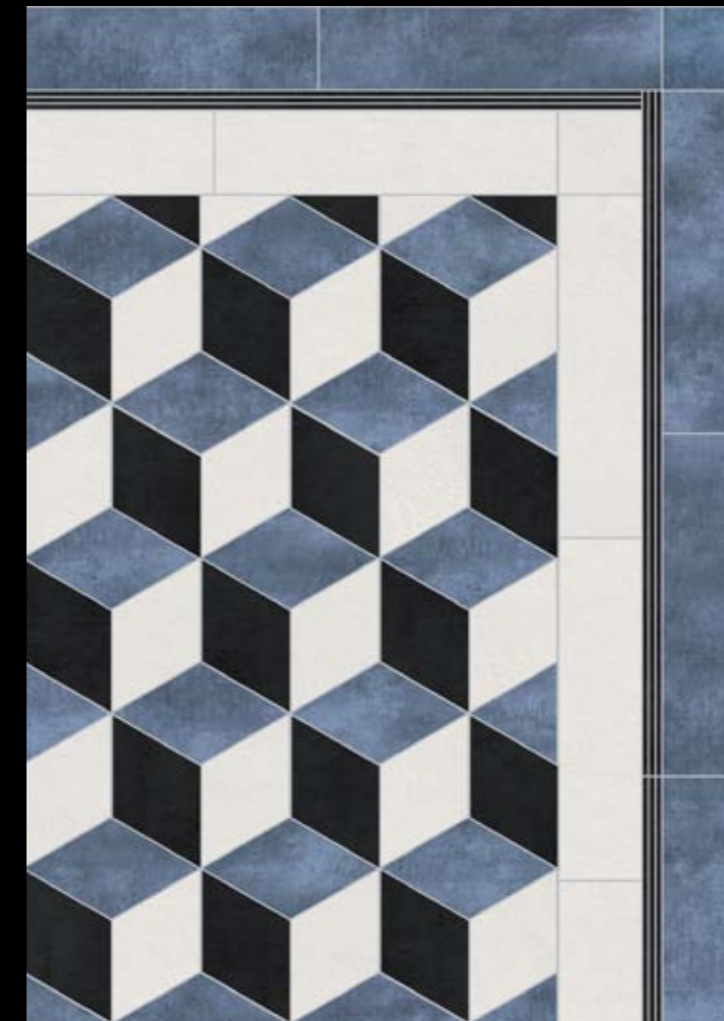
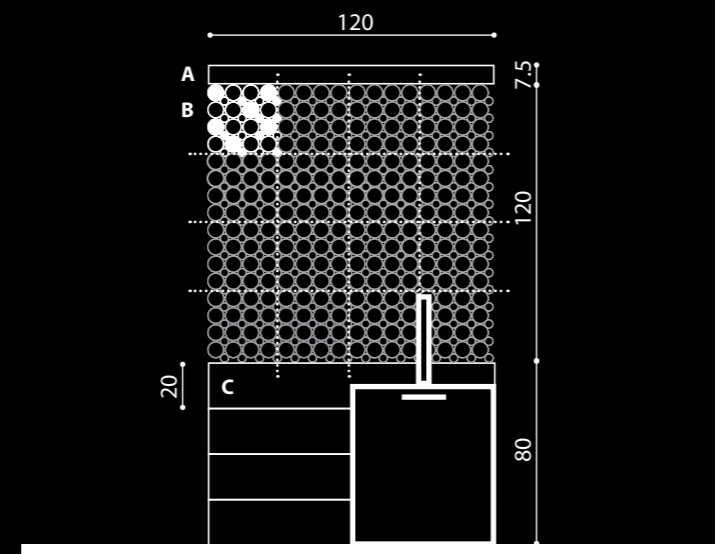
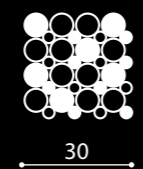

**LAYOUT 7.3**

A Diamond 18x18 cm · Concrete Graphite 33.33% · 12.30 pcs/sqm  
 B Diamond 18x18 cm · Concrete Ice 33.33% · 12.30 pcs/sqm  
 C Diamond 18x18 cm · Concrete Snow 33.33% · 12.30 pcs/sqm

**ALTRI FORMATI · OTHER SHAPES**

D 60x15 cm · Krea Blue  
 E 60x15 cm · Concrete Ice  
 F Stripes Mosaic 15x120 cm [3 stripes of 1.5x120 cm] · Concrete Graphite



La Casa del Navigatore · The House of the Seafarer



CUCINA Navigatore

p. 60

KITCHEN Seafarer

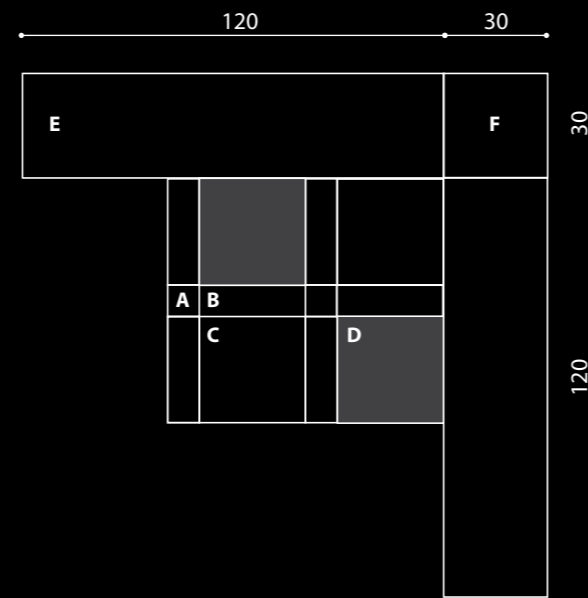
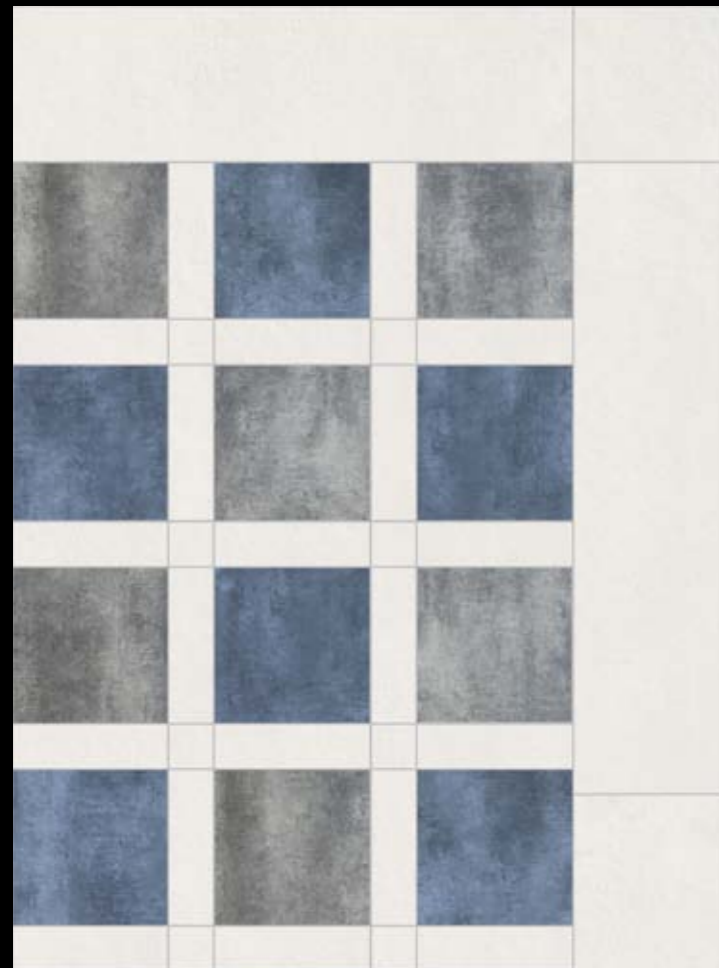

PAV · FLOOR

LAYOUT 5.3

- A Small 9x9 cm · Concrete Ice 5.33% · 6.57 pcs/sqm
- B Plate 9x30 cm · Concrete Ice 35.50% · 13.15 pcs/sqm
- C 30x30 cm · Krea Silver 29.59% · 3.29 pcs/sqm
- D 30x30 cm · Krea Blue 29.59% · 3.29 pcs/sqm

ALTRI FORMATI · OTHER SHAPES

- E 30x120 cm · Concrete Ice
- F 30x30 cm · Concrete Ice

RIV · WALL

120x60 cm · Concrete Ice

ZONA NOTTE 1 Navigatore

p. 65

BEDROOM 1 Seafarer

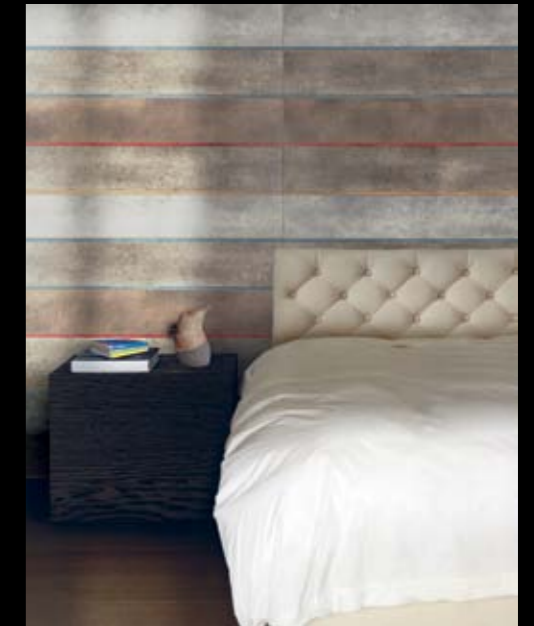

LAYOUT 14.3

- A 20x120 cm · Krea Snow 31% · 1.3 pcs/sqm
- B 20x120 cm · Krea Ground 31% · 1.3 pcs/sqm
- C 20x120 cm · Krea Nut 31% · 1.3 pcs/sqm
- D Stripes Mosaic Krea Mix 15x120 cm [1 stripe 1.5x120 cm] 7% · 0.4 pcs/sqm

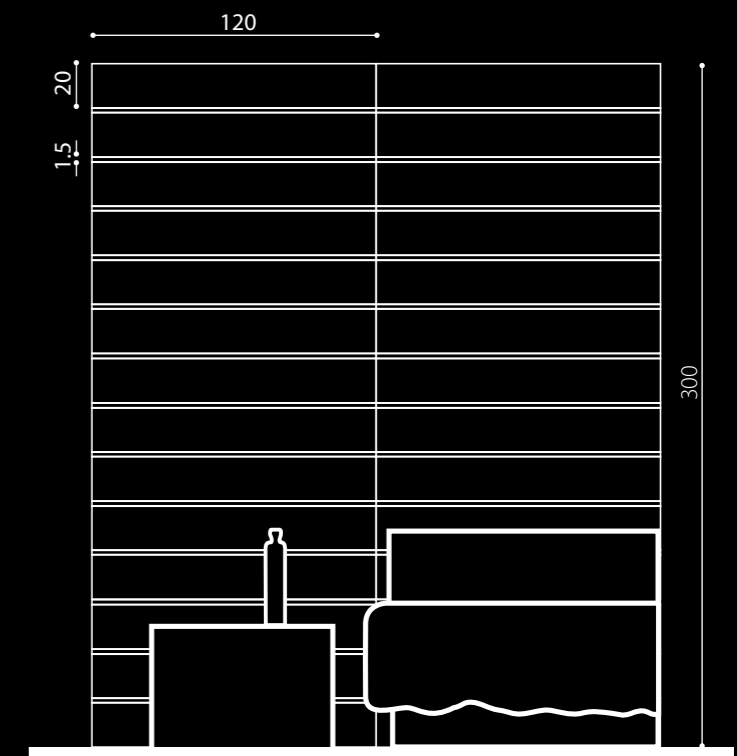



La Casa del Navigatore · The House of the Seafarer



ZONA NOTTE 2 Navigatore

p. 67

BEDROOM 2 Seafarer

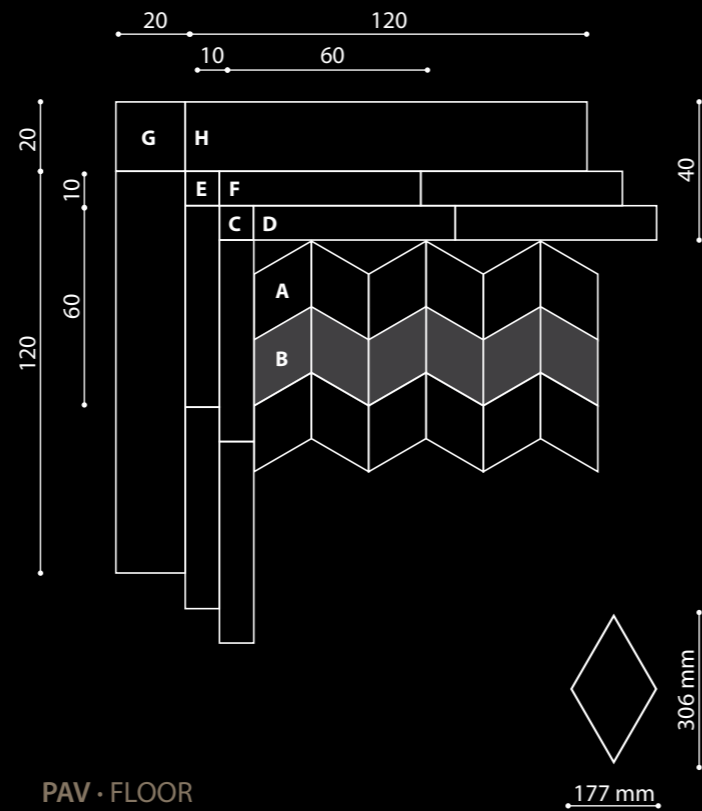

PAV · FLOOR

LAYOUT 9.3

- A Diamond 18x18 cm · Concrete White 50% · 18.45 pcs/sqm
- B Diamond 18x18 cm · Krea Blue 50% · 18.45 pcs/sqm

ALTRI FORMATI · OTHER SHAPES

- C · D 10x10 cm + 10x60 cm · Concrete White
- E · F 10x10 cm + 10x60 cm · Krea Blue
- G · H 20x20 cm [cut on site] + 20x120 cm · Concrete White

RIV · WALL

- 120x120 cm · Concrete White

BAGNO Navigatore

p. 71

BATHROOM Seafarer

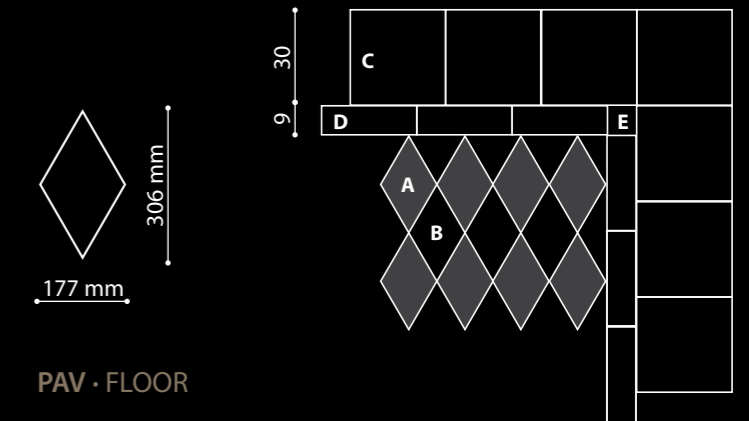
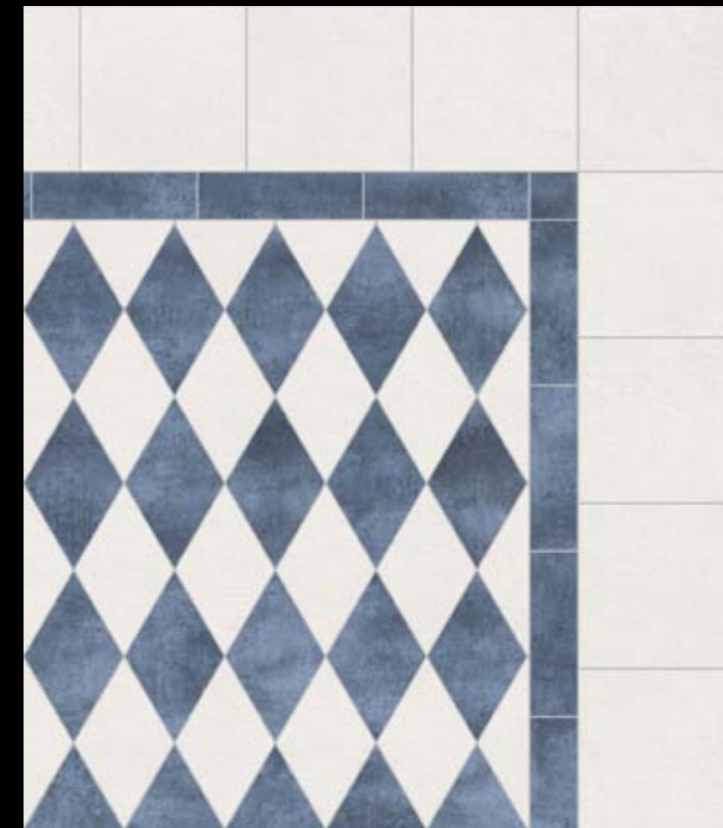

PAV · FLOOR

LAYOUT 8.2

- A Diamond 18x18 cm · Krea Blue 50% · 18.45 pcs/sqm
- B Diamond 18x18 cm · Concrete Ice 50% · 18.45 pcs/sqm

ALTRI FORMATI · OTHER SHAPES

- C 30x30 cm · Concrete Ice
- D Plate 9x30 cm · Krea Blue
- E Small 9x9 cm · Krea Blue

RIV · WALL

- F 120x120 cm · Krea Silver
- G Stripes Mosaic 15x120 cm [2 stripes 1.5x120 cm] · Krea Blue

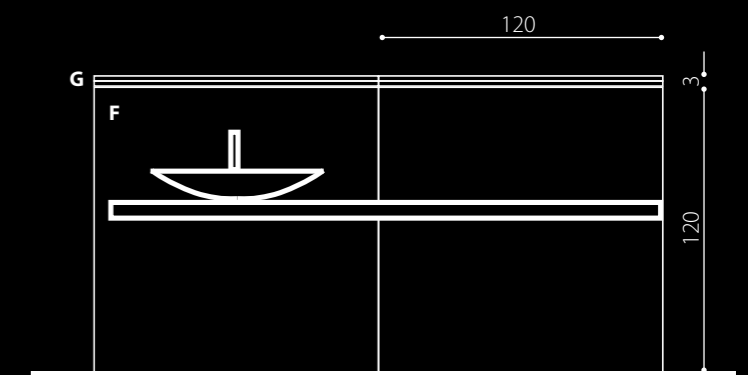



La Casa del Navigatore · The House of the Seafarer



**SOGGIORNO** Navigatore

p. 72

LIVING ROOM Seafarer

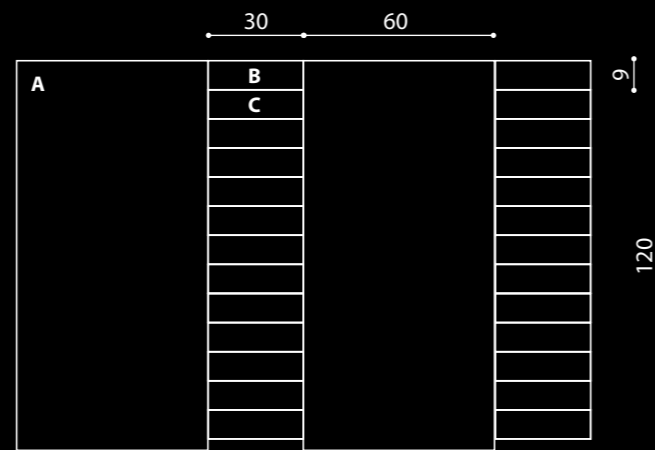
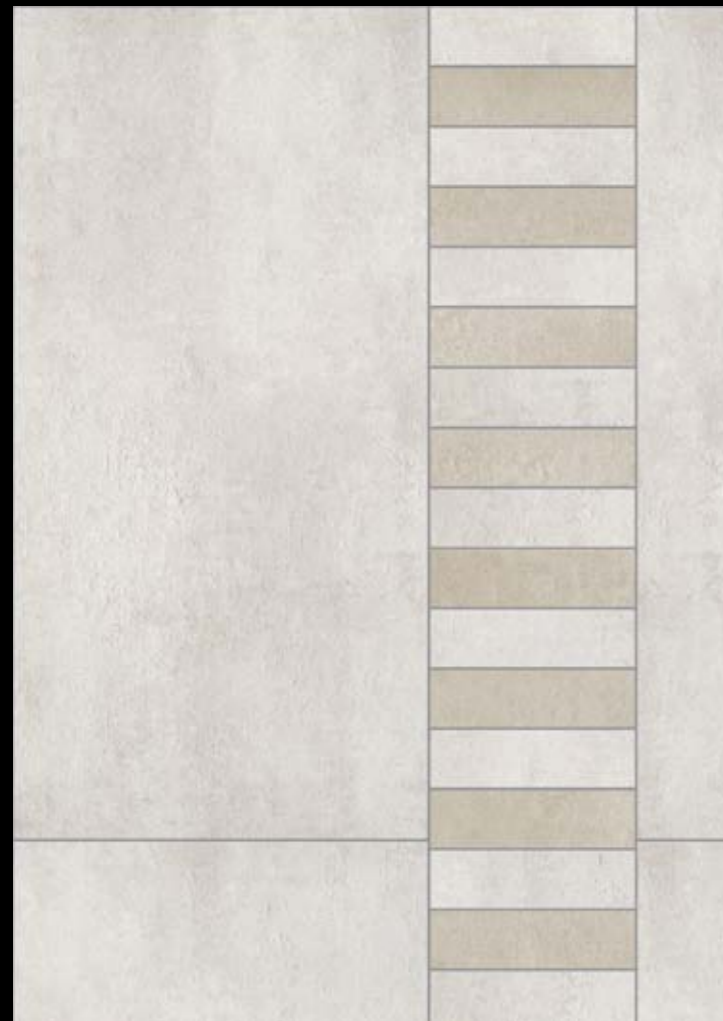

**LAYOUT 15.2**

- A** 60x120 cm · Concrete White 66.67% · 0.93 pcs/sqm
- B** Plate 9x30 cm · Concrete White 16.67% · 6.3 pcs/sqm
- C** Plate 9x30 cm · Concrete Rope 16.67% · 6.3 pcs/sqm

**RISTORANTE** Navigatore

p. 77

RESTAURANT Seafarer

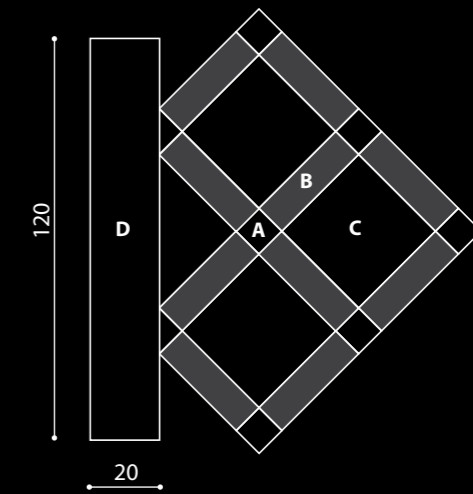

**LAYOUT 5.2**

- A** Small 9x9 cm · Concrete Rope 5.33% · 6.57 pcs/sqm
- B** Plate 9x30 cm · Concrete White 35.5% · 13.15 pcs/sqm
- C** 30x30 cm · Concrete Rope 59.17% · 6.57 pcs/sqm

**ALTRI FORMATI · OTHER SHAPES**

- D** 20x120 cm · Concrete Rope



La Casa del Musicista · The House of the Musician



INGRESSO Musicista

p. 83

ENTRANCE Musician

STANZE Musicista

p. 85

ROOMS Musician

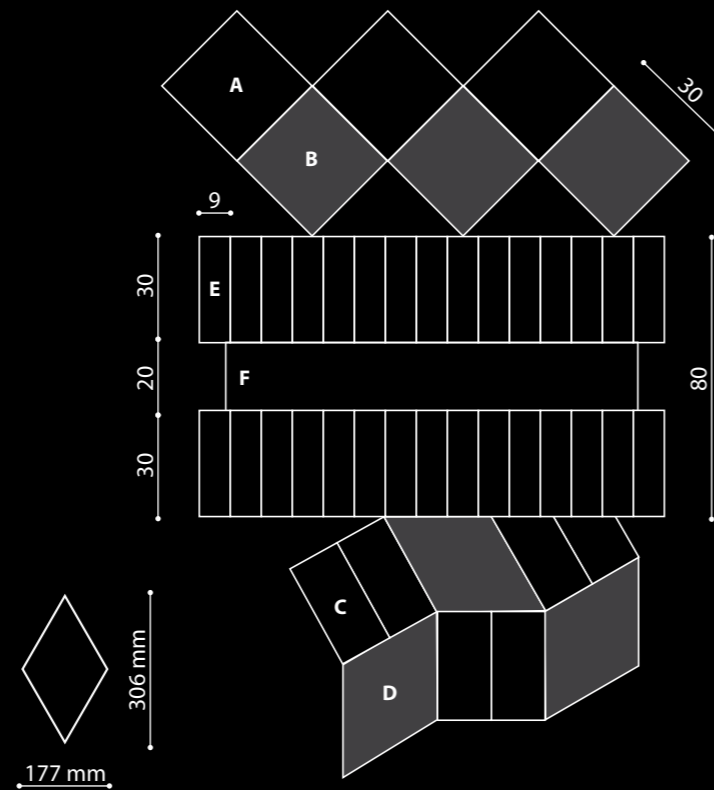

**LAYOUT 1.2**

A 30x30 cm · Krea Silver 50% · 5.6 pcs/sqm  
 B 30x30 cm · Krea Green 50% · 5.6 pcs/sqm

**LAYOUT 13.2**

C Brick 9x18 cm · Krea Silver 37% · 22.86 pcs/sqm  
 D Diamond 18x18 · Krea Red 63% · 11.43 pcs/sqm

**ALTRI FORMATI · OTHER SHAPES**

E Plate 9x30 cm · Krea Silver  
 F 20x120 cm · Krea Silver

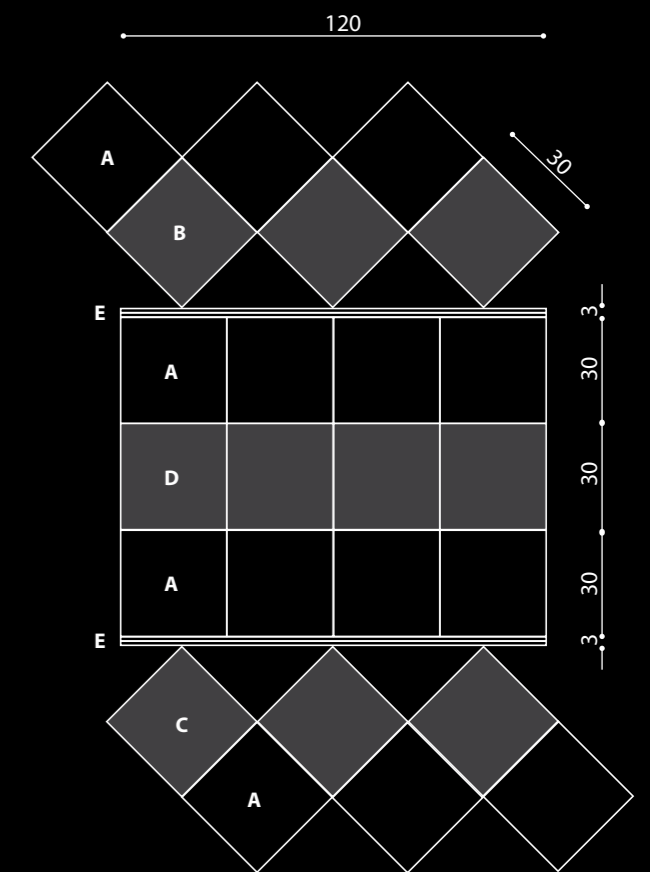

**LAYOUT 1.2**

A 30x30 cm · Concrete White 50% · 5.6 pcs/sqm  
 B 30x30 cm · Krea Green 50% · 5.6 pcs/sqm

**LAYOUT 1.2**

A 30x30 cm · Concrete White 50% · 5.6 pcs/sqm  
 C 30x30 cm · Krea Red 50% · 5.6 pcs/sqm

**ALTRI FORMATI · OTHER SHAPES**

D 30x30 cm · Krea Silver  
 E Stripes Mosaic 15x120 cm [2 stripes 1.5x120 cm] · Krea Silver



La Casa del Musicista · The House of the Musician



**SOGGIORNO** Musicista

p. 88

LIVING ROOM Musician

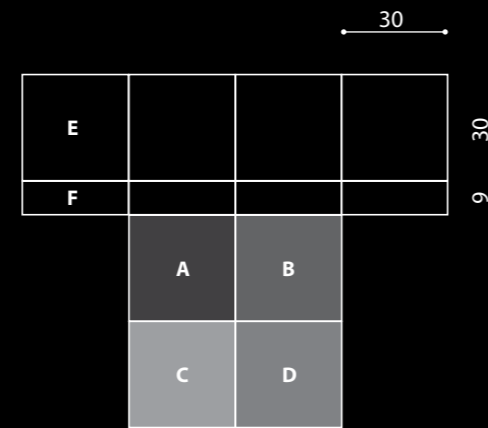

PAV · FLOOR

**LAYOUT 1.4**

- A 30x30 cm · Concrete White 25% · 2.78 pcs/sqm
- B 30x30 cm · Concrete Beige 25% · 2.78 pcs/sqm
- C 30x30 cm · Concrete Brown 25% · 2.78 pcs/sqm
- D 30x30 cm · Krea Green 25% · 2.78 pcs/sqm

**ALTRI FORMATI · OTHER SHAPES**

- E 30x30 cm · Concrete Graphite
- F Plate 9x30 cm · Concrete Beige

RIV · WALL

120x120 cm · Concrete Beige

**ZONA NOTTE** Musicista

p. 93

BEDROOM Musician

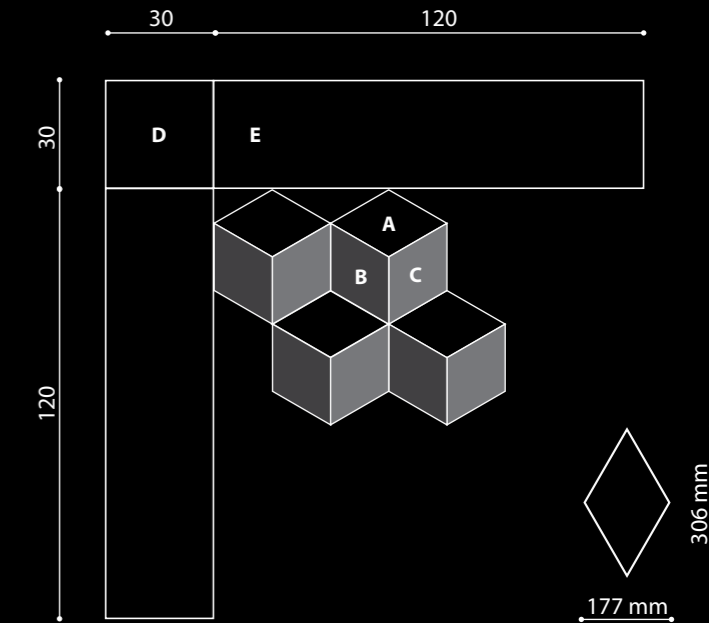
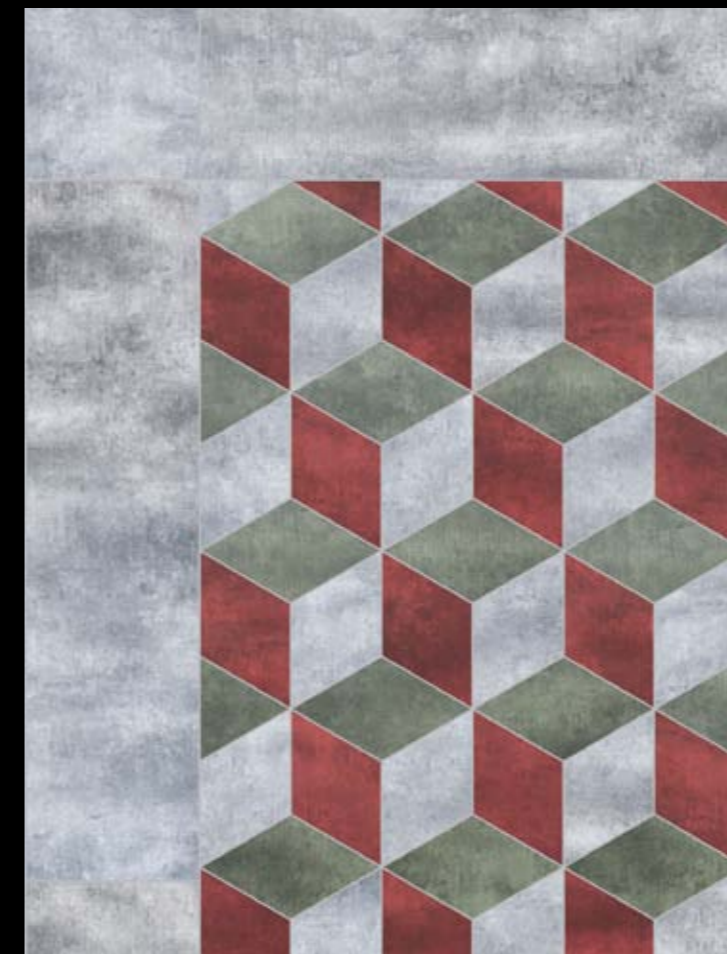

**LAYOUT 7.3**

- A Diamond 18x18 cm · Krea Green 33.33% · 12.30 pcs/sqm
- B Diamond 18x18 cm · Krea Red 33.33% · 12.30 pcs/sqm
- C Diamond 18x18 cm · Krea Snow 33.33% · 12.30 pcs/sqm

**ALTRI FORMATI · OTHER SHAPES**

- D 30x30 cm · Krea Snow
- E 30x120 cm · Krea Snow



La Casa del Musicista · The House of the Musician



RISTORANTE Musicista

p. 94

RESTAURANT Musician

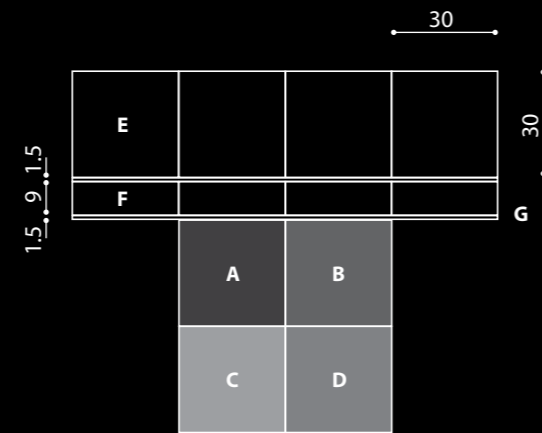

PAV · FLOOR

LAYOUT 1.4

- A 30x30 cm · Krea Ground 25% · 2.78 pcs/sqm
- B 30x30 cm · Krea Red 25% · 2.78 pcs/sqm
- C 30x30 cm · Krea Snow 25% · 2.78 pcs/sqm
- D 30x30 cm · Krea Green 25% · 2.78 pcs/sqm

ALTRI FORMATI · OTHER SHAPES

- E 30x30 cm · Krea Ground
- F Plate 9x30 cm · Krea Snow
- G Stripes Mosaic 15x120 cm [1 stripe 1.5x120 cm] · Concrete Graphite

RIV · WALL

- H 120x120 cm · Concrete Rope
- I Stripes Mosaic 15x120 cm [1 stripe 1.5x120 cm] · Krea Green
- J Mosaic 30x30 cm [1 little piece 1.5x1.5 cm] · Krea Red

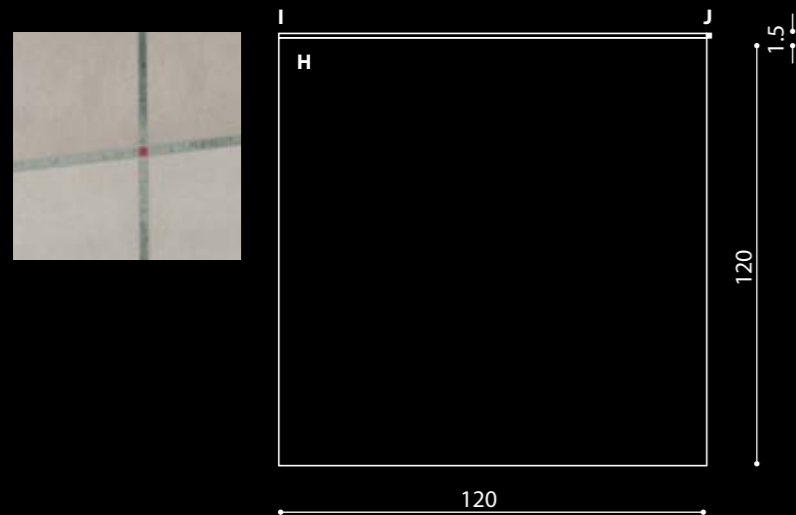



# Sistema Playone

## Playone System

GRES PORCELLANATO MULTISTRATO  
MULTILAYER PORCELAIN SLABS

≠ 4.8 mm

SPESSORE  
THICKNESS

16

COLORI  
COLOURS

20

FORMATI  
SHAPES

PLAYONE [!]

GRAPHITE

ICE

SILVER

NUT

SMOKE

GREY

SNOW

BLUE

RED

GREEN

BEIGE

WHITE

ROPE

GROUND

ORANGE

BROWN

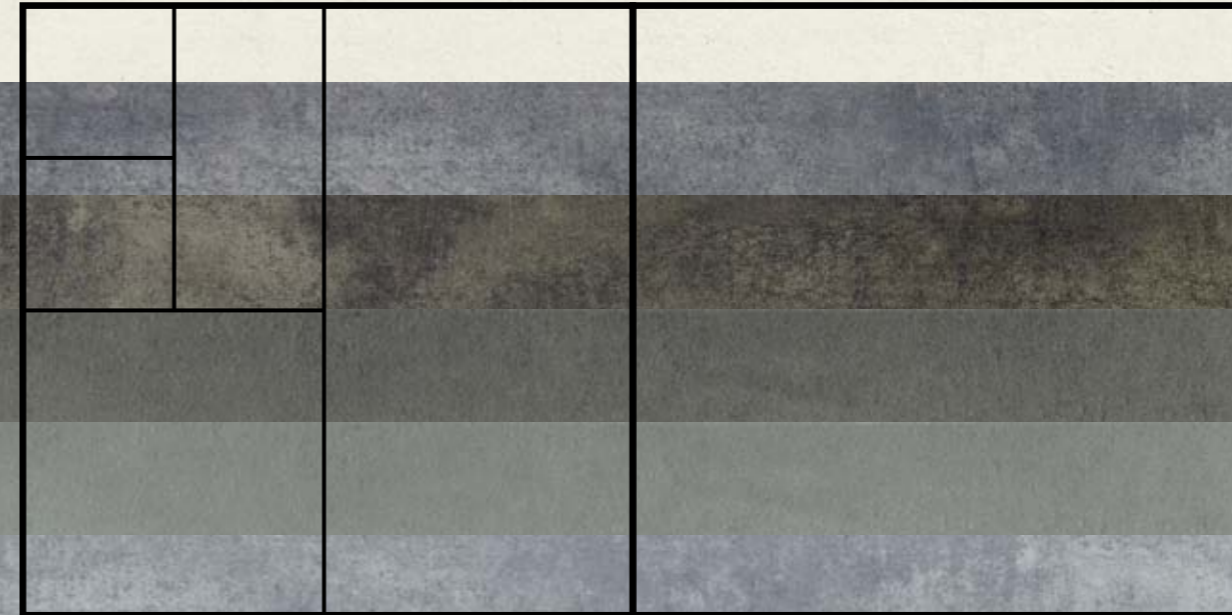

Large size · modulare

- 120x120 cm
- 120x60 cm
- 120x30 cm
- 120x40 cm
- 120x20 cm
- 60x60 cm
- 60x30 cm
- 60x15 cm
- 60x10 cm



**Diamond**  
18x18 cm



**30x30**



**Plate**  
9x30 cm



**Brick**  
9x18 cm



**Small**  
9x9 cm



**Button**  
3x3 cm



**Octagon**  
30x30 cm

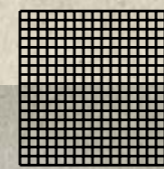

**Mosaic**  
30x30 cm



**Action Mosaic**  
30x30 cm

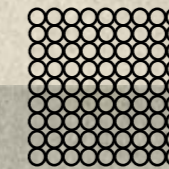

**Circle Mosaic small**  
30x30 cm

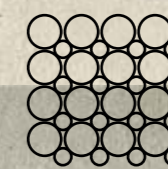

**Circle Mosaic big**  
30x30 cm

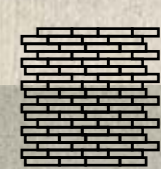

**Wall Mosaic**  
30x30 cm



**Stripes Mosaic**  
15x120 cm



# Schemi di posa

## Layout

Gli schemi di posa sono stati calcolati con una approssimazione. Per calcolare le quantità di pezzi necessari alla posa fare sempre riferimento alla tabella calibri [p. 138]. Fuga consigliata 2 mm.

The laying patterns are approximations. To calculate the quantities required for installation, please refer to the calibers table [p. 138]. Joint spacing recommended 2 mm.

LAYOUT 1.1

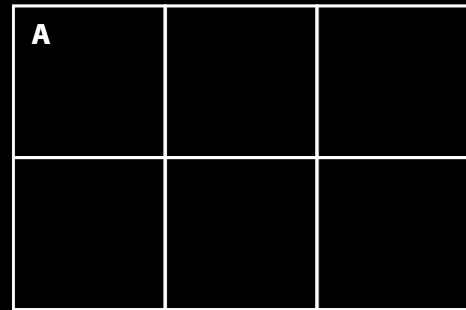

**A** 30x30 cm 100% · 11.1 pcs/sqm

LAYOUT 1.2

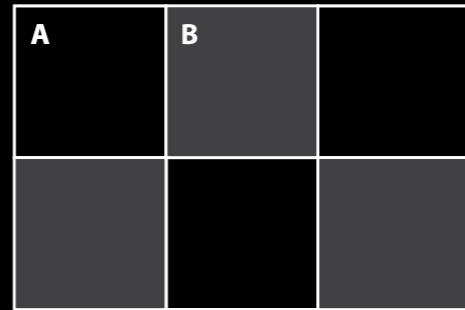

**A** 30x30 cm 50% · 5.6 pcs/sqm  
**B** 30x30 cm 50% · 5.6 pcs/sqm

LAYOUT 5.2

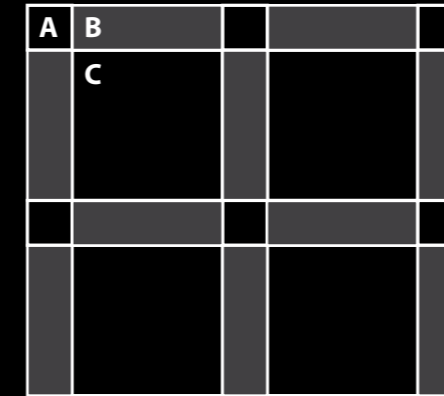

**A** Small · 9x9 cm 5.33% · 6.57 pcs/sqm  
**B** Plate · 9x30 cm 35.5% · 13.15 pcs/sqm  
**C** 30x30 cm 59.17% · 6.57 pcs/sqm

LAYOUT 5.3

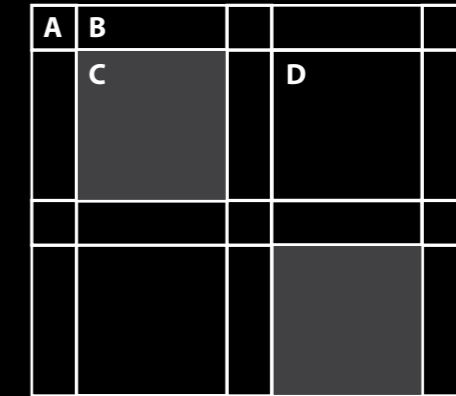

**A** Small · 9x9 cm 5.33% · 6.57 pcs/sqm  
**B** Plate · 9x30 cm 35.50% · 13.15 pcs/sqm  
**C** 30x30 cm 29.59% · 3.29 pcs/sqm  
**D** 30x30 cm 29.59% · 3.29 pcs/sqm

LAYOUT 2.2

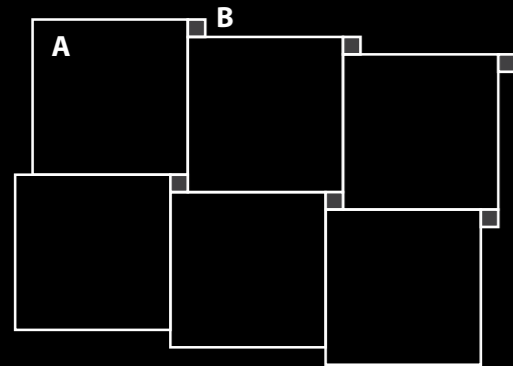

**A** 30x30 cm 99.12% · 11.1 pcs/sqm  
**B** Button · 3x3 cm 0.88% · 7.93 pcs/sqm

LAYOUT 2.4

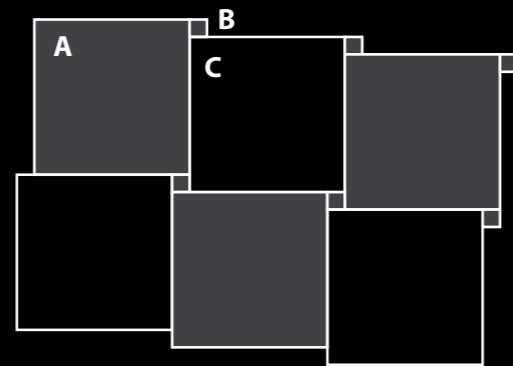

**A** 30x30 cm 49.56% · 5.56 pcs/sqm  
**B** Button · 3x3 cm 0.88% · 7.93 pcs/sqm  
**C** 30x30 cm 49.56% · 5.56 pcs/sqm

LAYOUT 7.1

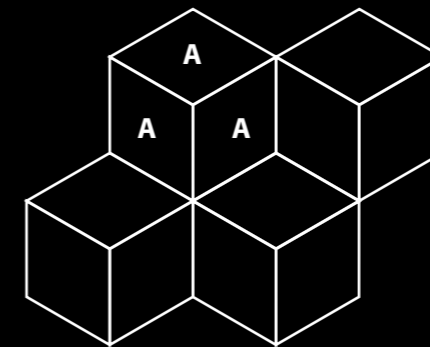

**A** Diamond · 18x18 cm 100% · 37.00 pcs/sqm

LAYOUT 7.2

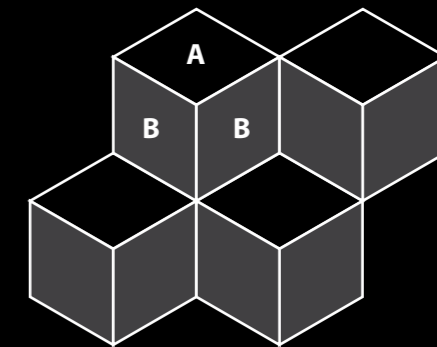

**A** Diamond · 18x18 cm 33.33% · 12.30 pcs/sqm  
**B** Diamond · 18x18 cm 66.66% · 24.60 pcs/sqm

LAYOUT 1.1

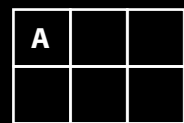

**A** Small · 9x9 cm 100% · 123.46 pcs/sqm

LAYOUT 1.2



**A** Small · 9x9 cm 50% · 61.73 pcs/sqm  
**B** Small · 9x9 cm 50% · 61.73 pcs/sqm

LAYOUT 2.2

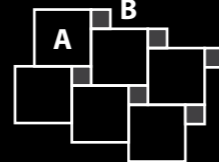

**A** Small · 9x9 cm 90.74% · 111.11 pcs/sqm  
**B** Button · 3x3 cm 9.26% · 111.11 pcs/sqm

LAYOUT 2.4

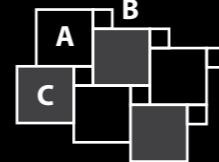

**A** Small · 9x9 cm 45.37% · 55.56 pcs/sqm  
**B** Button · 3x3 cm 9.26% · 111.11 pcs/sqm  
**C** Small · 9x9 cm 45.37% · 55.56 pcs/sqm

LAYOUT 7.3

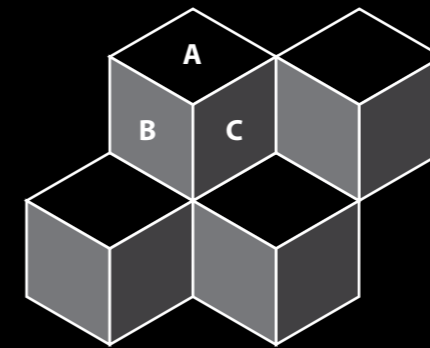

**A** Diamond · 18x18 cm 33.33% · 12.30 pcs/sqm  
**B** Diamond · 18x18 cm 33.33% · 12.30 pcs/sqm  
**C** Diamond · 18x18 cm 33.33% · 12.30 pcs/sqm

LAYOUT 10.3

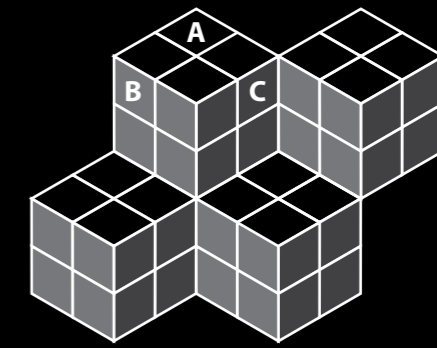

**A** Diamond · 18x18 cm 33.33% · 12.30 pcs/sqm  
**B** Diamond · 18x18 cm 33.33% · 12.30 pcs/sqm  
**C** Diamond · 18x18 cm 33.33% · 12.30 pcs/sqm



# Schemi di posa

## Layout

Gli schemi di posa sono stati calcolati con una approssimazione. Per calcolare le quantità di pezzi necessari alla posa fare sempre riferimento alla tabella calibri [p. 138]. Fuga consigliata 2 mm.

The laying patterns are approximations. To calculate the quantities required for installation, please refer to the calibers table [p.138]. Joint spacing recommended 2 mm.

LAYOUT 9.3

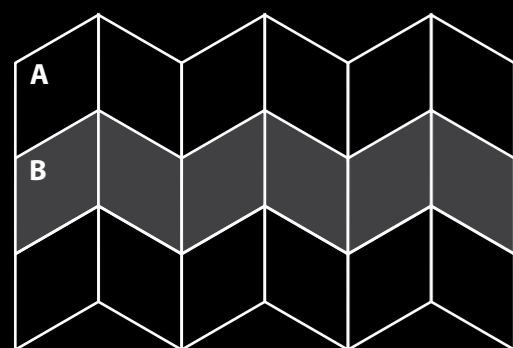

**A Diamond · 18x18 cm** 50% · 18.45 pcs/sqm  
**B Diamond · 18x18 cm** 50% · 18.45 pcs/sqm

LAYOUT 8.2

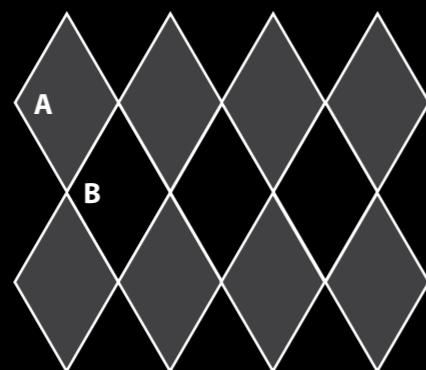

**A Diamond · 18x18 cm** 50% · 18.45 pcs/sqm  
**B Diamond · 18x18 cm** 50% · 18.45 pcs/sqm

LAYOUT 6.5

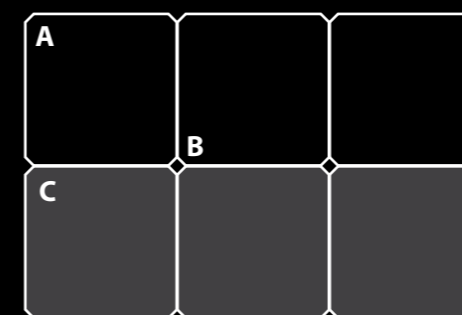

**A Octagon · 30x30 cm** 49.50% · 5.61 pcs/sqm  
**B Button · 3x3 cm** 1% · 11.22 pcs/sqm  
**C Octagon · 30x30 cm** 49.50% · 5.61 pcs/sqm

LAYOUT 13.2

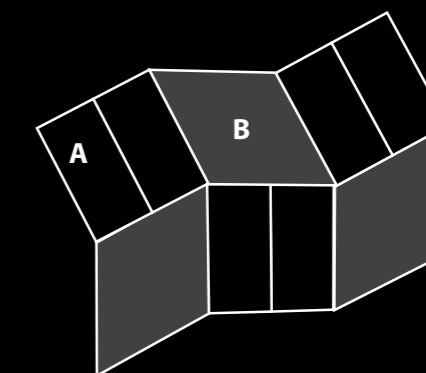

**A Brick · 9x18 cm** 37% · 22.86 pcs/sqm  
**B Diamond · 18x18 cm** 63% · 11.43 pcs/sqm

LAYOUT 8.4

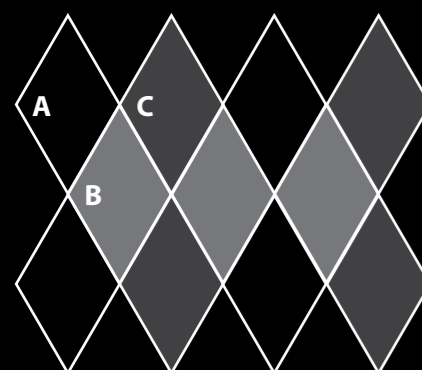

**A Diamond · 18x18 cm** 25% · 9.23 pcs/sqm  
**B Diamond · 18x18 cm** 50% · 18.45 pcs/sqm  
**C Diamond · 18x18 cm** 25% · 9.23 pcs/sqm

LAYOUT 8.5

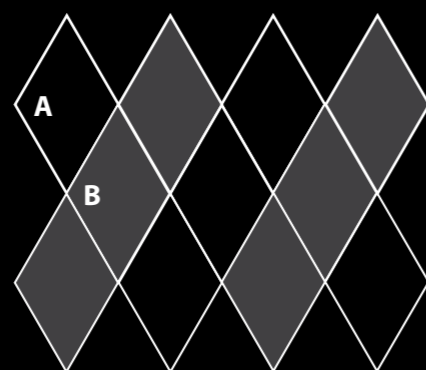

**A Diamond · 18x18 cm** 50% · 18.45 pcs/sqm  
**B Diamond · 18x18 cm** 50% · 18.45 pcs/sqm

LAYOUT 1.4

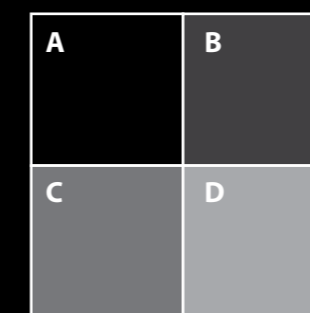

**A 30x30 cm** 25% · 2.78 pcs/sqm  
**B 30x30 cm** 25% · 2.78 pcs/sqm  
**C 30x30 cm** 25% · 2.78 pcs/sqm  
**D 30x30 cm** 25% · 2.78 pcs/sqm

LAYOUT 14.3

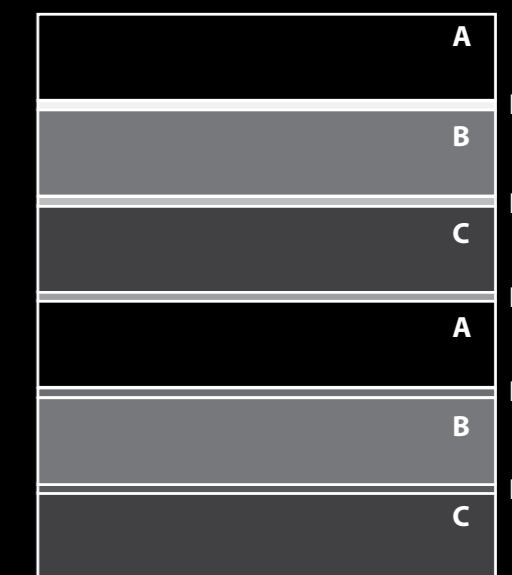

LAYOUT 6.2

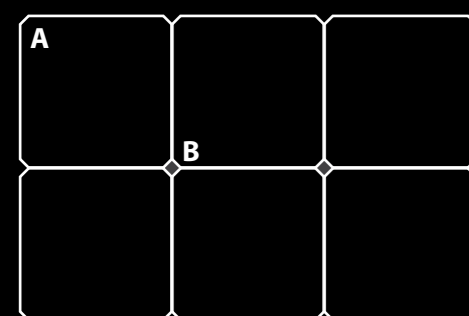

**A Octagon · 30x30 cm** 99% · 11.22 pcs/sqm  
**B Button · 3x3 cm** 1% · 11.22 pcs/sqm

LAYOUT 6.3

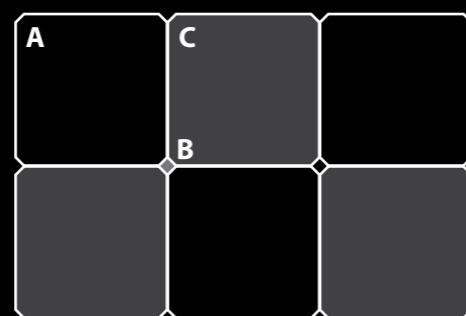

**A Octagon · 30x30 cm** 49.50% · 5.61 pcs/sqm  
**B Button · 3x3 cm** 1% · 11.22 pcs/sqm  
**C Octagon · 30x30 cm** 49.50% · 5.61 pcs/sqm

LAYOUT 15.2

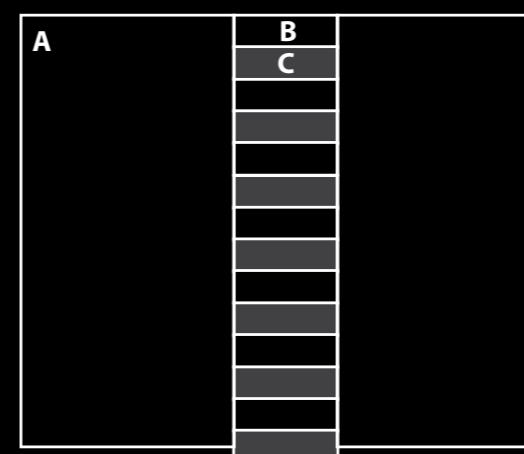

**A 60x120 cm** 66.67% · 0.93 pcs/sqm  
**B 9x30 cm** 16.67% · 6.3 pcs/sqm  
**C 9x30 cm** 16.67% · 6.3 pcs/sqm

**A 20x120 cm** 31% · 1.3 pcs/sqm  
**B 20x120 cm** 31% · 1.3 pcs/sqm  
**C 20x120 cm** 31% · 1.3 pcs/sqm  
**D Stripe Mosaic Krea mix 15x120 cm** 7% · 0.4 pcs/sqm  
 [1 stripe 1.5x120 cm]



# Formati e colori

## Shapes and colours



	Diamond 18x18 cm	30x30	Plate 9x30 cm	Brick 9x18 cm	Small 9x9 cm	Button 3x3 cm	Octagon 30x30 cm	Mosaic 30x30 cm	Mosaic mix 30x30 cm	Action Mosaic 30x30 cm	Circle Mosaic small 30x30 cm	Circle Mosaic small mix 30x30 cm	Circle Mosaic big 30x30 cm	Circle Mosaic big mix 30x30 cm	Wall Mosaic 30x30 cm	Wall Mosaic mix 30x30 cm	Stripes Mosaic 15x120 cm	Stripes Mosaic Krea mix 15x120 cm	
Concrete ICE	•	•	•	•	•	•	•	•		•	•	•	•	•	•		•		
Concrete WHITE	•	•	•	•	•	•	•	•		•					•	•	•	•	
Concrete ROPE	•	•	•	•	•	•	•	•		•					•			•	
Concrete BEIGE	•	•	•	•	•	•	•	•		•					•	•		•	
Concrete GREY	•	•	•	•	•	•	•	•		•					•		•	•	
Concrete SMOKE	•	•	•	•	•	•	•	•		•					•		•	•	
Concrete GRAPHITE	•	•	•	•	•	•	•	•		•	•	•	•	•	•		•	•	
Concrete BROWN	•	•	•	•	•	•	•	•		•					•	•		•	
Krea BLUE	•	•	•	•	•	•	•	•		•								•	•
Krea GREEN	•	•	•	•	•	•	•	•		•								•	•
Krea ORANGE	•	•	•	•	•	•	•	•		•								•	•
Krea RED	•	•	•	•	•	•	•	•		•								•	•
Krea NUT	•	•	•	•	•	•	•	•	•									•	•
Krea GROUND	•	•	•	•	•	•	•	•	•									•	•
Krea SNOW	•	•	•	•	•	•	•	•	•									•	•
Krea SILVER	•	•	•	•	•	•	•	•	•									•	•

PZ/COLLO · PCS/BOX	9	22	22	22	44	22	22	10	10	10	4	4	4	4	10	10	4	4
M2/COLLO · SQM/BOX	0.2430	1.98	0.5940	0.3564	0.3564	0.0198	1.98											
KG/COLLO · KGS/BOX	2.9	22.00	6.45	3.95	3.95	0.3936	21.40	12.00	12.00	12.00	5.00	5.00	5.00	5.00	12.00	12.00	6.5	6.5



# Formati e colori

## Shapes and colours

PLAY ONE [!]



	60x60	60x30	60x15	60x10	120x120	120x60	120x40	120x30	120x20
Concrete <b>ICE</b>	•	•	•	•	•	•	•	•	•
Concrete <b>WHITE</b>	•	•	•	•	•	•	•	•	•
Concrete <b>ROPE</b>	•	•	•	•	•	•	•	•	•
Concrete <b>BEIGE</b>	•	•	•	•	•	•	•	•	•
Concrete <b>GREY</b>	•	•	•	•	•	•	•	•	•
Concrete <b>SMOKE</b>	•	•	•	•	•	•	•	•	•
Concrete <b>GRAPHITE</b>	•	•	•	•	•	•	•	•	•
Concrete <b>BROWN</b>	•	•	•	•	•	•	•	•	•
Krea <b>BLUE</b>	•	•	•	•	•	•	•	•	•
Krea <b>GREEN</b>	•	•	•	•	•	•	•	•	•
Krea <b>ORANGE</b>	•	•	•	•	•	•	•	•	•
Krea <b>RED</b>	•	•	•	•	•	•	•	•	•
Krea <b>NUT</b>	•	•	•	•	•	•	•	•	•
Krea <b>GROUND</b>	•	•	•	•	•	•	•	•	•
Krea <b>SNOW</b>	•	•	•	•	•	•	•	•	•
Krea <b>SILVER</b>	•	•	•	•	•	•	•	•	•

<b>PZ/COLLO</b> · PCS/BOX	5	10	16	30	2	4	4	5	6
<b>M2/COLLO</b> · SQM/BOX	1.80	1.80	1.44	1.80	2.88	2.88	1.92	1.80	1.44
<b>KG/COLLO</b> · KGS/BOX	20.00	20.00	16.00	19.00	32.00	32.00	21.50	20.00	16.00



# Note tecniche

## Technical notes

### → Sustainable Thinking.

Curiamo con particolare attenzione:

- la sicurezza ed il comfort del personale addetto alla produzione;
- il rispetto dell'ambiente in cui sorge lo stabilimento;
- la sicurezza del personale sul cantiere, garantita da imballaggi studiati per facilitare la movimentazione e completamente riciclabili.

Produciamo grandi lastre ceramiche grazie all'applicazione di tecnologie all'avanguardia, nel rispetto (spesso anche in senso molto migliorativo) delle vigenti normative europee sull'ambiente. Per questo i macchinari si trovano in ambienti insonorizzati, l'illuminazione della linea produttiva è a basso regime, esiste un monitoraggio ambientale in tempo reale, il sistema di imballaggio – sidepack – prevede, prima della pressatura, l'utilizzo di quantità di cartone minime e comunque i materiali dell'imballo sono completamente riciclabili e privi di colle.

La nuova lastra sottile 4.8 è di fatto il nuovo orizzonte del risparmio energetico in ceramica: offre la possibilità di produrre gres porcellanato di altissima qualità con notevole risparmio di energia sia durante il processo di cottura sia durante il trasporto.

### → Innovazione Tecnologica. Un processo produttivo intelligente.

Il processo produttivo di GIGACER prevede la preparazione preliminare di un unico formato, **grandi lastre** in gres porcellanato **120x120 cm**, multistrato a tutta massa, che possono essere successivamente tagliate e modificate a freddo in molteplici altri formati e superfici mantenendo la **massima garanzia** di requisiti tecnici qualitativi ed estetici.

Questa serie di lastre caratterizzate da superiori prerogative tecniche ed estetiche viene prodotta in gres porcellanato a tutta massa multistrato con una tecnologia assolutamente innovativa. L'impianto è stato progettato appositamente per produrre grandi formati e utilizza la tecnologia definita "CONTINUA" che prevede prima della pressatura, una fase di precompattazione della lastra multistrato a tutta massa che permette di ottenere speciali effetti decorativi senza ricorrere all'uso di smalti, ma solo con la distribuzione di impasti porcellanati colorati di qualità. Gli spessori delle lastre prodotte sono di 12 mm e 4.8 mm.

### → Calibri.

Le nostre lastre rettificate hanno dimensioni come da tabella Calibro 09.

Calibro Caliber	Lato 120 Slide 120	Lato 90 Slide 90	Lato 60 Slide 60	Lato 40 Slide 40	Lato 30 Slide 30	Lato 20 Slide 20	Lato 15 Slide 15	Lato 10 Slide 10	Lato 5 Slide 5
05	1186.00	889.00	592.00	394.00	295.00	196.00	146.50	97.00	47.50
06	1187.00	889.25	592.50	394.33	295.25	196.16	146.63	97.08	47.54
07	1188.00	890.50	593.00	394.67	295.50	196.33	146.75	97.17	47.59
08	1189.00	891.25	593.50	395.00	295.75	196.50	146.88	97.25	47.63
09	1190.00	892.00	594.00	395.33	296.00	196.66	147.00	97.33	47.67
1	1191.00	892.75	594.50	395.67	296.25	196.83	147.13	97.42	47.71
2	1192.00	893.50	595.00	396.00	296.50	197.00	147.25	97.50	47.75
3	1193.00	895.25	595.50	396.33	296.75	197.16	147.38	97.58	47.79
4	1194.00	895.00	596.00	396.67	297.00	197.33	147.50	97.67	47.84
5	1195.00	895.75	596.50	397.00	297.25	197.50	147.63	97.75	47.88

Misure nominali Nominal sized	Misure reali Real sized
3 cm	27 mm
9 cm	87.5 mm
18 cm	177 mm
30 cm	296 mm

### → Sustainable Thinking.

We pay close attention to:

- the safety and comfort of our production staff;
- the respect for the environment in and around the factory;
- the safety of tile layers in the building site, which is guaranteed by the specially designed packaging that makes movement easier and that is completely recyclable.

We manufacture large porcelain slabs thanks to the application of advanced technologies, in accordance with the current European environmental standards (and often with even better results). For this reason the engines are installed in soundproof areas, the lighting around the production area is low emission, there is an environmental monitoring in real time, the complete packaging (sidepack) uses minimum quantities of cardboard and, however, the material used for packaging is completely recyclable and glueless.

The new 4.8 thin slab is in fact the most advanced system concerning energy saving: it give us the possibility of manufacturing high quality porcelain stoneware tiles with a remarkable energy saving, both for firing and carriage.

### → Innovazione Tecnologica. Un processo produttivo intelligente.

GIGACER production process starts from **large porcelain slabs**, size **120x120 cm**, homogeneous multilayer. The slabs can then be cut in many other submultiples and worked again to get different finishes, preserving their **top quality** and aesthetic features.

These homogeneous multilayer porcelain slabs show superior technical and aesthetical characteristics thanks to a highly innovative technology. The equipment has been realized on purpose to manufacture large sizes and uses an innovative technology called "CONTINUA". This technology foresees a pre-compacting phase before pressing, that allows to achieve special decorative effects without using glazes, but only distributing the porcelain mixed powders on the body. The thickness of the manufactured slabs are 12 mm and 4.8 mm.

### → Calibers.

Standard dimensions of our slabs are in accordance with caliber 09.



≠ 4.8 mm

Per scaricare la documentazione tecnica completa vai al sito: [www.gigacer.it](http://www.gigacer.it) - [www.playone.it](http://www.playone.it)  
To download complete technical information, visit the website: [www.gigacer.it](http://www.gigacer.it) - [www.playone.it](http://www.playone.it)

PLAY ONE [!]

### → Manuale di Utilizzo.

Le lastre di 4.8 mm sono: resistenti, sottili, leggere, facili da movimentare e da tagliare, resistenti al fuoco, ingelive, ecocompatibili e non necessitano di particolari accorgimenti per la manutenzione. È un prodotto ideale per pavimenti e rivestimenti interni ed esterni, ed è particolarmente adatto nel caso di ristrutturazione di pavimentazioni e rivestimenti residenziali: si applica sull'esistente senza opere di demolizione e relativi costi di smaltimento.

GIGACER 4.8mm è idoneo al rivestimento di pareti interne ed esterne tramite incollaggio e in situazioni che necessitano di un minor aggravio di peso sulle strutture. Il 4.8mm è perfettamente abbinabile ai pavimenti della stessa collezione in spessore tradizionale, dei quali mantiene non solo le stesse caratteristiche estetiche, ma anche il medesimo calibro e modularità.

Il 4.8mm è un prodotto dal design ecologico: lo spessore ridotto comporta un minor impatto ambientale in termini di consumo di energia, materie prime, imballo e trasporti. Costituisce una valida alternativa al gres porcellanato di spessore tradizionale in tutti i casi in cui il minor spessore e la leggerezza costituiscono un fattore determinante.

### → User Manual.

The 4.8mm slabs are resistant, thin, lightweight, easy to handle and cut, fire-resistant, frostproof, environmentally friendly and require no special care for maintenance. 4.8mm is an ideal product for interior and exterior cladding. 4.8mm slabs are particularly suitable in the case of renovation of residential floors and walls: they can be laid on the existing floor, allowing a dramatic demolition and disposal cost savings.

GIGACER 4.8mm is suitable to indoor and outdoor wall covering and it is particularly indicated in all cases where it is preferable not to load too much weight on the building's structure. 4.8mm can be combined with the 12mm slabs of every collection because it has the same caliber and it is perfectly modular with 2mm joints.

4.8mm is a green product: it allows savings in terms of energy consumption, raw materials, packaging and transport. It is a valid alternative to the traditional 12mm in all those cases where lightness and less thickness represent a determinant variable.

#### Caratteristiche tecniche technical specifications ≠ 4.8 mm

LASTRE DI GRES PORCELLANATO MULTISTRATO MULTILAYER PORCELAIN SLABS ISO 13006 - G - Bla UGL (E ≤ 0,5%) UNI EN 14411 - G -

	CARATTERISTICHE TECNICHE TECHNICAL SPECIFICATIONS	NORMA ISO STANDARD	VALORI PRESCRITTI DALLE NORME INTERNATIONAL STANDARDS	VALORE MEDIO GIGACER AVERAGE GIGACER VALUE
	CARATTERISTICHE DIMENSIONALI DIMENSIONAL CHARACTERISTICS		<b>S &gt; 410</b>	
	LATI SIDES	ISO 10545-2	± 0,6%	± 0,2%
	SPESSORE THICKNESS		± 5%	± 3%
	RETTILINEITÀ DEGLI SPIGOLI STRAIGHTNESS OF EDGES		± 0,5%	± 0,2%
	ORTOGONALITÀ RECTANGULARITY		± 0,6%	± 0,2%
	PLANARITÀ SURFACE FLATNESS		± 0,5%	± 0,2%
	ASSORBIMENTO D'ACQUA WATER ABSORPTION	ISO 10545-3	≤ 0,5%	≤ 0,1%
	RESISTENZA ALLA FLESSIONE BENDING STRENGTH	ISO 10545-4	≥ 35N/mm <sup>2</sup>	≥ 40N/mm <sup>2</sup>
	MODULO DI ROTTURA MODULUS OF RUPTURE	ISO 10545-4	> 700N (sp. ≤ 7,5mm)	> 700N
	RESISTENZA ALL'ABRAZIONE PROFONDA RESISTANCE TO DEEP ABRASION	ISO 10545-6	≤ 175 mm <sup>3</sup>	≤ 145 mm <sup>3</sup>
	COEFFICIENTE DI DILATAZIONE TERMICA LINEARE COEFFICIENT OF LINEAR THERMAL EXPANSION	ISO 10545-8	≤ 9X10 <sup>-6</sup> c <sup>-1</sup>	≤ 7X10 <sup>-6</sup> c <sup>-1</sup>
	RESISTENZA AGLI SBALZI TERMICI RESISTANCE TO THERMAL SHOCKS		METODO DISPONIBILE AVAILABLE METHOD	RESISTE RESISTANT
	RESISTENZA AL GELO FROST RESISTANCE	ISO 10545-12	METODO DISPONIBILE AVAILABLE METHOD	RESISTE RESISTANT
	RESISTENZA ALL'ATTACCO CHIMICO RESISTANCE TO CHEMICAL ATTACKS	ISO 10545-13	min. UB	RESISTE RESISTANT
	RESISTENZA DEI COLORI ALLA LUCE COLOUR RESISTANCE TO LIGHT	DIN 51094	NON DEVONO PRESENTARE APPREZZABILI VARIAZIONI DI COLORE THE PRODUCT MUST NOT EVIDENCE CLEAR COLOUR VARIATIONS	RESISTE RESISTANT
			<b>CONCRETE KREA</b>	
	RESISTENZA ALLE MACCHIE STAIN RESISTANCE	ISO 10545-14	METODO DISPONIBILE AVAILABLE METHOD	RESISTE RESISTANT
	COEFFICIENTE D'ATTRITO COEFFICIENT OF FRICTION	DIN 51130 DIN 51097 BCR	- - -	R10 - > 0,40

Trattandosi di un prodotto tecnico a tutto impasto alcune impurità e puntinature visibili nei colori chiari sono da considerarsi una caratteristica tecnica del prodotto. Playone is technical unglazed porcelain stoneware and some little dots or impurities on bright colours are to be considered as aesthetic features of the product.





Gigacer S.p.A.  
Via Caltagirone 72  
48018 Faenza (RA) Italy  
t. +39 0546 637111  
f. +39 0546 637127  
info@gigacer.it  
www.gigacer.it  
www.playone.it



ENVIRONMENTAL MANAGEMENT  
SYSTEM CERTIFICATE  
UNI EN ISO 14001:2004  
(ISO 14001:2004)

QUALITY MANAGEMENT  
SYSTEM CERTIFICATE  
UNI EN ISO 9001:2008  
(ISO 9001:2008)



Copia catalogo ad esclusivo  
uso interno. Non è consentita la  
divulgazione dei contenuti.

*Catalogue edition for internal use only.  
Contents cannot be used or reproduced  
under any circumstances.*

Publicato da / Published by:  
Gigacer S.p.A.

Art direction e graphic design:  
Laura Ferrari  
Cabriolet  
www.cabrioletstudio.com  
03-2014

Stampa / Printing:  
Ruggeri Grafiche  
www.ruggerigrafiche.it

I colori possono risultare falsati dai  
procedimenti litografici.  
*The colors could be altered the lithographic  
printing process.*



# PLAY ONE [!]

